

Thermostatic Control Valves

Model 6B Steel and Stainless Steel

Typical applications

- Lubricating oil temperature control
- Jacket water high temperature (HT)
- Secondary water low temperature (LT)
- Heat recovery
- Water saving applications
- Boiler inlet temperature control
- Co-generation, cooling towers
- Temperature mixing or diverting
- Engine and compressor cooling system

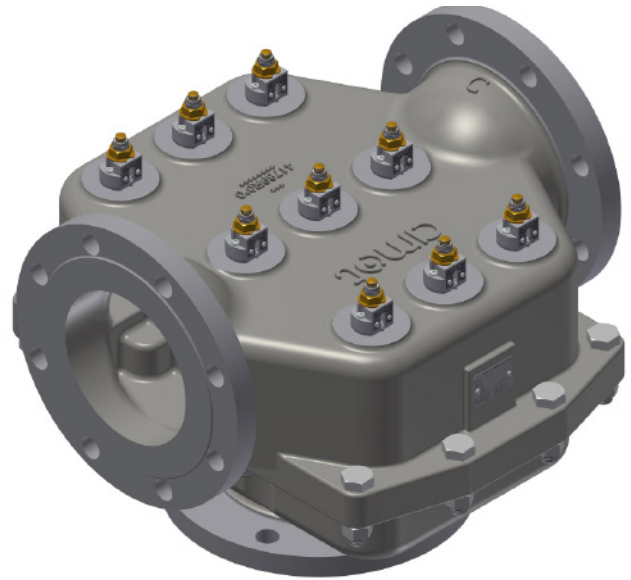

Key benefits

- No external power source required - simple, low cost installation
- No user setting needed - 'fit and forget' solution
- Small number of parts - simple maintenance and low cost of ownership
- Robust design capable of high vibration and shock applications
- Easy installation, operates in any mounting position
- Automatic self-sensing control with positive proportional valve action

Key features

- Flow rates of 150 - 280 m³/hr fresh water (660 - 1230 US gpm)
- Material: steel and stainless steel
- DN150, 6" pipe size
- Flanged connections
- Tamper-proof temperature settings from 13°C to 116°C (55°F to 240°F)
- Pressure ratings up to 19.6 bar for ASTM A216 WCB and 19 bar for ASTM A351 CF8M

Accreditations available

- PED Suitable for Group 1 & 2 liquids (Ensure materials are compatible)
- ATEX  11 2 G
- CE Complies with all relevant EU directives



www.amot.com

Thermostatic Control Valves - Model 6B ST and SS

Overview

The AMOT model 6B steel and stainless steel thermostatic valve may be mounted in any position and uses the proven expanding wax principle to actuate the 3-way temperature element assemblies. The valve may be used for diverting or mixing service and makes very economical temperature limiting valves for engine and lubricating oil skids where high design specifications may be required for the complete module.

Leakholes

In some applications, it is necessary to have leak holes drilled in the element to ensure a small flow between ports A and C. Leakholes are available in sizes ranging from 1.6 mm to 12.7 mm ($\frac{1}{16}$ " to $\frac{1}{2}$ ").

Temperature settings

Temperature settings are available from 13°C to 116°C (55°F to 240°F). In general, the temperature quoted is the nominal operating temperature in diverting mode on water systems. For long life, AMOT valves should not be operated continuously at temperatures in excess of 14°C (25°F) of their maximum continuous rating. If this condition is anticipated then consult AMOT for suitable alternatives.

For mixing and oil circuits the temperature may be one to two degrees higher due to flow, viscosity and other system parameters. Elements and seals are available in a variety of materials. These materials are suitable for most applications. Please refer to the Temperature Control Valve Selection Guide for material compatibility information.

Manual override (BR & BM)

Manual override is often a requirement for marine applications. In automatic mode the valve will control the temperature automatically, but actuating the manual override mechanism on top of the valve will cause the element to move towards its hot (extended) position, regardless of temperature. Each element assembly has its own override. Manual Override should only be used in case of an emergency or element failure.

BR type valves are fitted with a variable manual override which allows a progressive opening of port A to C. BM type valves are fitted with an on/off manual override.

Applications

Diverting Applications

When valves are used for diverting service, the inlet is Port A (temperature sensing port), with Port C being connected to the cooler, and Port B connected to the cooler by-pass line.

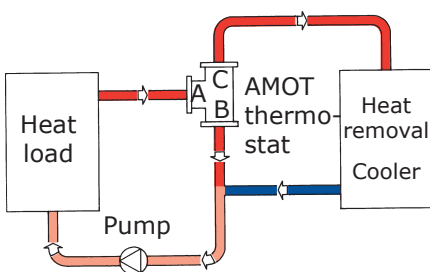

Mixing Applications

For mixing service, Port C is the cold fluid inlet port from the cooler, Port B is the hot by-pass fluid inlet, and Port A the common outlet. Port A is the temperature sensing port and will mix the hot and cold fluids in the correct proportion so as to produce the desired outlet temperature leaving Port A.

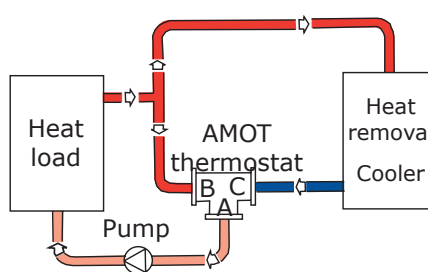

2-way Water Saving Applications

Valve as shown maintains minimum flow through cooler to conserve water. Requires internal leak hole to permit small flow for sensing.

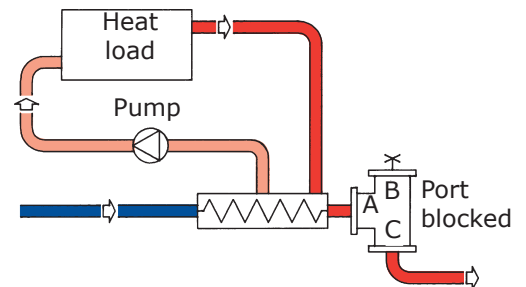

Thermostatic Control Valves - Model 6B ST and SS

Valve characteristics

Pressure drop (Metric units)

AMOT thermostatic valves are designed to produce minimal pressure drop. The normal recommendation in sizing the valves is to select a pressure drop between 0.14 to 0.5 Bar (2 and 7 PSI).

— Water

AMOT thermostatic valves operate in any position and may be oriented at the convenience of the system designer. In the smaller sizes, the valve may be supported by the connecting pipe but should not be subjected to excessive bending. Line up the piping before tightening the connecting bolts. Larger sizes should not be used to support long and heavy lengths of pipe, nor used to draw up lengths of pipe which have been fabricated too short.

If the valve is mounted at the high point of the system, the system should be properly vented to prevent trapping air at the temperature element assemblies.

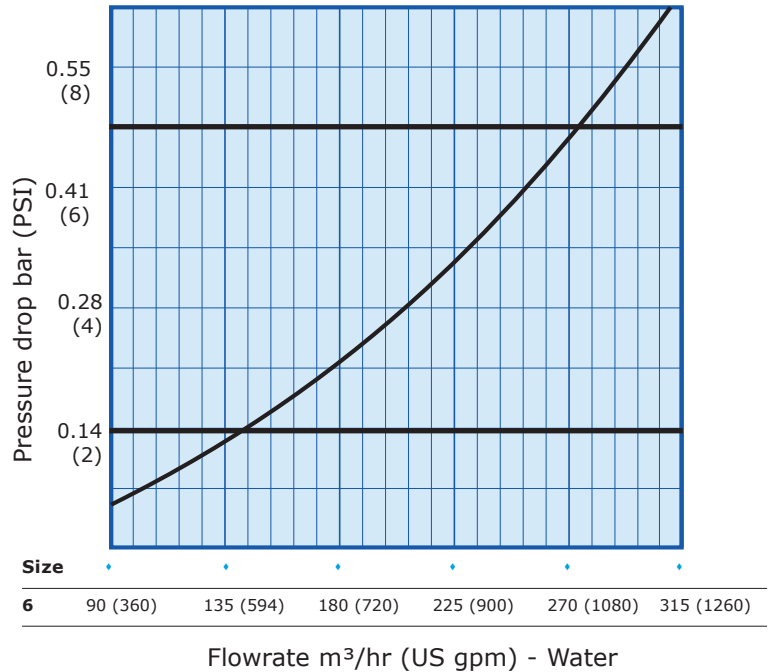

Flow coefficient

AMOT valve flow coefficient (calculated)

Size	Kv	Cv
6B	394	456

Kv is the flow coefficient in metric units. It is defined as the flow rate in cubic meters per hour (m³/h) of water at a temperature of 16° celsius with a pressure drop across the valve of 1 bar. Cv is the imperial coefficient. It is defined as the flow rate in US Gallons per minute [gpm] of water at a temperature of 60° fahrenheit with a pressure drop across the valve of 1 psi. (Kv = 0.865 Cv / Cv = 1.156 Kv)

The basic formula to determine the Kv of a valve is:

$$Kv = Q \sqrt{\frac{SG}{Dp}}$$

Q = Flow (m³/h)
 Dp = Pressure drop (bar)
 SG = Specific gravity of fluid
 Kv = Valve flow coefficient

There are two other ways that this formula can be used to find the flow in m³/h or pressure drop of a valve in bar:

$$Q = Kv \sqrt{\frac{Dp}{SG}} \quad Dp = \left[\frac{Q}{Kv} \right]^2 SG$$

The basic formula to determine the Cv of a valve is:

$$Cv = Q \sqrt{\frac{SG}{Dp}}$$

Q = Flow (US gallons/min)
 Dp = Pressure drop (psi)
 SG = Specific gravity of fluid
 Cv = Valve flow coefficient

There are two other ways that this formula can be used to find the flow in US gallons/minute or pressure drop of a valve in PSI:

$$Q = Cv \sqrt{\frac{Dp}{SG}} \quad Dp = \left[\frac{Q}{Cv} \right]^2 SG$$

Thermostatic Control Valves - Model 6B ST and SS

Valve dimensions

mm (inches)

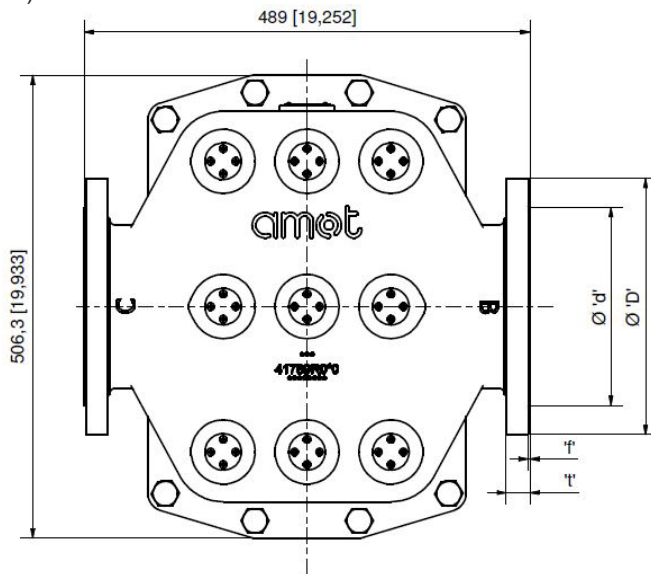

Approximate Weight
137 kg / 302 lbs

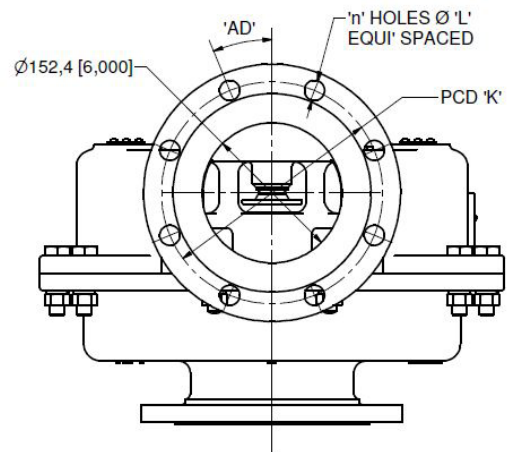
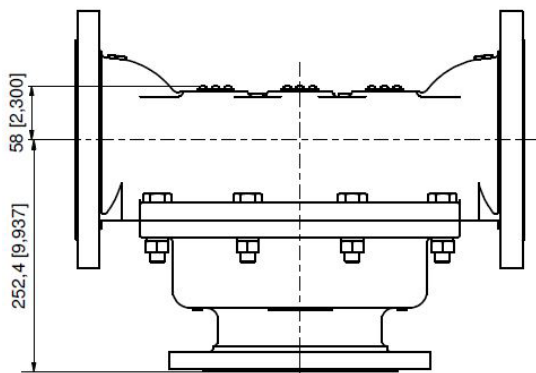

MATERIAL	FLANGE STANDARD	FLANGE RATING	RAISED / FLAT FACE	D	t	k	d	n
				DIA "D"	FLANGE THICKNESS "t"	PCD 'K'	HOLES DIA 'L'	No OF HOLES 'n'
Steel	EN 1092-1	PN 10/PN16	Raised	285±4.0	24±1.0	240 ±1.0	22+0.3 / -0	8
Stainless Steel		PN 10/PN16	Raised	285±4.0	24±1.0	240 ±1.0	22+0.3 / -0	8
Steel	ASME B16.5	CLASS 150	Raised	280	25.9+3/-0	241.3 ±1.5	22.225±0.15	8
Stainless Steel		CLASS 150	Raised	280	25.9+3/-0	241.3 ±1.5	22.225±0.15	8

Thermostatic Control Valves - Model 6B ST and SS

How to order

Use the tables below to select the unique specification of your B Valve.

Example: **A B C D E F - G H - I**

Model 6 BO R J 145 01 - 0 0 - AA

A Valve Size		
	Nominal Bore Size	No. of Elements
6	6 in (DN150)	9

B Model & Revision Level	
BO	Non manual override
BM	Manual override (available from USA only)
BR	Variable manual override

C Body Material	
R	Stainless Steel
S	Steel

D Port Connection	
B	Flanged PN10
C	Flanged PN16
J	Flanged ANSI 150 lb

E Control Temperature								
Code	Control temp.		Rated range				Max temp continuous	
	°C	°F	Crack open		Full open		°C	°F
			°C	°F	°C	°F		
55	13	55	8	47	20	68	35	95
57	14	57	10	50	18	65	30	86
75	24	75	20	68	30	86	38	100
90	32	90	27	81	35	95	43	110
95	35	95	29	85	41	105	49	120
100	38	100	34	93	42	108	50	122
105	41	105	35	95	45	113	55	131
110	43	110	38	100	47	117	56	133
115	46	115	40	104	50	122	61	142
120	49	120	43	110	54	130	66	150
130	54	130	51	124	60	140	68	155
135	57	135	54	129	63	145	71	160
140	60	140	57	135	66	151	74	165
145	63	145	60	140	69	156	79	174
150	66	150	63	145	72	161	82	180
155	68	155	66	150	74	165	85	185
160	71	160	68	155	78	173	88	190
165	74	165	71	160	80	175	88	190
170	77	170	74	165	83	181	93	200
175	79	175	77	170	85	185	102	215
180	82	180	79	175	88	191	104	220
185	85	185	82	180	91	196	106	223
195	91	195	87	188	98	209	107	225
205	96	205	93	200	102	215	108	226
215	102	215	98	209	107	225	115	239
225	107	225	102	216	113	236	118	244
230	110	230	104	219	115	239	118	244
240	116	240	108	227	122	252	123	253.5

F	Part no.	Element and valve seal material
01	1096X (temp °F)	standard with Nitrile seals
02	1096P (temp °F)	plated with Viton seals
03	1096X (temp °F)	with Viton seals
05	6836S (temp °F)	saltwater with Nitrile seals
07	2433X (temp °F)	manual override with Nitrile seals
09	6938S (temp °F)	saltwater manual override with Nitrile seals
11	5566X (temp °F)	reduced stroke with Nitrile seals
12	5566P (temp °F)	reduced stroke plated with Viton seals
20	5566X (temp °F)	reduce stroke with Viton seals
44	1096X (temp °F)	with Neoprene seals
45	1096P (temp °F)	with Neoprene seals
53	2433X (temp °F)	with Viton seals

G	Leakhole size - inches (mm)
0	None
A	1/2 in (13 mm)
B	1/4 in (6.5 mm)
C	3/8 in (9.5 mm)
D	1/8 in (3.2 mm)
E	1/16 in (1.6 mm)
F	3/32 in (2.4 mm)
G	3/16 in (5 mm)
H	5/16 in (8 mm)

H	Leakhole Quantity
0	None
1	One
2	Two
3	Three
4	Four
5	Five
6	Six
7	Seven
8	Eight
9	Nine

I Customer Special Requirements	
-AA	Standard product
-***	Customer special code assigned

Americas

AMOT USA
8824 Fallbrook Dr
Houston, TX 77064
USA

Tel +1 (281) 940 1800
Fax +1 (713) 559 9419
Email general: sales@amotusa.com
orders: orders@amotusa.com
customer service: cs@amotusa.com

Asia Pacific

AMOT Shanghai
Bd. 7A, No. 568, Longpan Rd.,
Malu Jiading
Shanghai 201801 China

Tel +86 (0) 21 5910 4052
Fax +86 (0) 21 5237 8560
Email shanghai@amot.com

Europe, Middle East and Africa

AMOT
Western Way
Bury St Edmunds
Suffolk, IP33 3SZ
United Kingdom

Tel +44 (0) 1284 762222
Fax +44 (0) 1284 760256
Email info@amot.com

AMOT Controls GmbH
Rondenbarg 25
22525 Hamburg
Germany

Tel +49 (0) 40 8537 1298
Fax +49 (0) 40 8537 1331
Email germany@amot.com