



AIR TORQUE

AIR TORQUE S.p.A.
 via Alla Campagna, N° 1
 24060 Costa di Mezzate (Bg) Italy
 Tel.: +39 035 682299
 Fax: +39 035 687791
 E-mail: info@airtorque.it

Model AT401 U
D/S - 90°

T.D.S. n° AT401U-DM
 Issued on: 04/10 - Page 1/1

Dimensions in mm

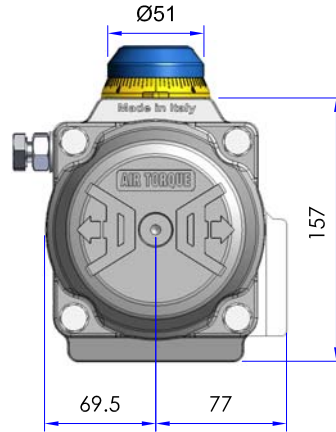
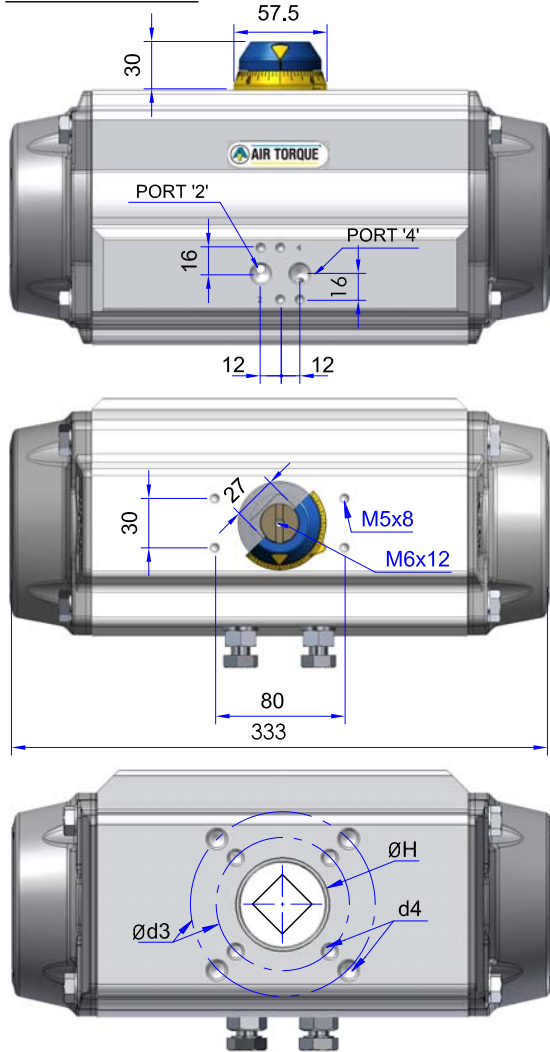

Optional Square:

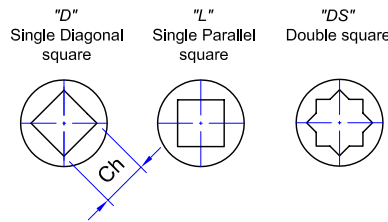

ISO 5211 Flange Dimensions Available

ISO 5211	STD		OPTIONAL
	F07 + F10	F10	
Ø d2	55	NA	70
d3	70	102	102
Ø d4	M8x12	M10x15	M10x15
Ø H	55		
Ch x l	17x25 - 22x24		
min. DS	22x35 - 27x29		
h min.	1,5	1,5	1,5
h1	2	NA	1,5

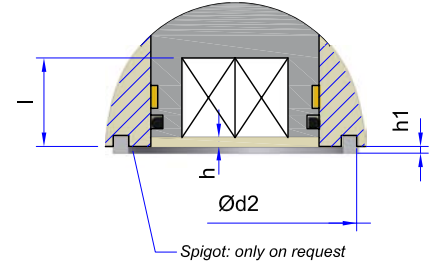

Connection / Attachment

Pressure connection: Port 2 and 4	G1/4"
Ancillary Attachment	AA2

Rotation and stroke adjustment

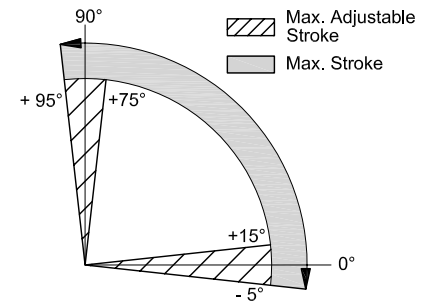

Output Torque

Pressure	OUTPUT TORQUE FOR DOUBLE ACTING IN Nm												APPROX. WEIGHT (Kg)
	2,5 bar	3 bar	3,5 bar	4 bar	4,2 bar	4,5 bar	5 bar	5,5 bar	6 bar	7 bar	8 bar		
0° 90°	138	166	194	222	233	249	277	305	332	388	443	9,97	

Pressure	OUTPUT TORQUE FOR SPRING RETURN IN Nm												Spring stroke	APPROX. WEIGHT (Kg)											
	2,5 bar	3 bar	3,5 bar	4 bar	4,2 bar	4,5 bar	5 bar	5,5 bar	6 bar	7 bar	8 bar														
	Start	End	Start	End	Start	End	Start	End	Start	End	Start	End													
S 05	86	56,1	114	83,8	141	111	169	139	180	150	197	167	224	195	82,4	52,5	10,97								
S 06	75,5	39,6	103	67,3	131	95	159	123	170	134	186	150	214	178	242	206	98,9	63	11,17						
S 07			92,7	50,8	120	78,5	148	106	159	117	176	134	203	162	231	189	259	217	115	73,5	11,37				
S 08					110	62	138	89,7	149	101	165	117	193	145	221	173	248	201	304	256	132	84	11,57		
S 09							127	73,3	138	84,3	155	101	182	129	210	156	238	184	293	239	349	295	148	94,5	11,77
S 10											144	84,5	172	112	200	140	227	168	283	223	338	278	165	105	11,97
S 11													161	95,7	189	123	217	151	272	206	328	262	181	116	12,17
S 12															179	107	206	135	262	190	317	245	198	126	12,37

Technical Data

Max. Pressure	Rotation (For STD)	Screw stroke Adjustment	Chamber Ø (mm)	Air Volume (L)		Moving Time (Sec.) (A)	
				Opening	Closing	Opening	Closing
8 bar	0° - 90°	For 1° adj. need 1/4 Turn	125	1,54	2,34	D 0,9 S 1,2	D 1,1 S 1,4

Operating Temperature Range

Operating Temperature (°C) (B)		
ST (standard)	HT (high temperature)	LLT (Extreme low temperature)
- 40 to + 80	- 15 to + 150	- 55 to + 80

A) - The above indicated moving time of the actuator is obtained in the following test conditions: (1) Room Temperature, (2) Actuator Stroke 90°, (3) Solenoid Valve with Orifice of 4 mm and a flow capacity Qn 400 L/min., (4) Inside pipe diameter 8 mm, (5) Medium clean air, (6) Air supply pressure 5,5 bar (79,75 Psi), (7) Actuator without external resistance load. **Caution: obviously on the field applications when one or more of the above parameters are different, the moving time will be different.**

B) - Every temperature range option requires proper components and lubricant. See technical data-sheet N° T.D.S. U00501E.

Operating Medium:

The operating medium must be free of dust and oil. The maximum particle size must not exceed 30µ (ISO 8573 Part1, Class5). In order to prevent water condensation and/or solidification (ice when actuator works below 0°C), the operating medium must have a dew point equal to -20°C or at least 10°C below the ambient temperature (ISO 8573 Part1, Class3).