

High Temperature Valves

Models 4075D & 4475B

Typical applications

- Jacket water temperature
- Compressor discharge temperature
- Steam temperature
- Lube oil temperature
- Process temperature





Model 4075D

Key features and benefits

- 316 Stainless Steel or Cast Aluminum available
- Field adjustable from 54°C to 260°C (130°F to 500°F)
- Reliable protection
- Few moving parts
- Easy installation - low maintenance
- Thermowell included
- Compatible with complete AMOT shutdown systems
- Viton seals

Accreditations available

- PED Suitable for Group 1 & 2 liquids
(Ensure materials are compatible)
- ATEX  II 2G TX X
-  Complies with all relevant EU directives

High Temperature Valves - Models 4075D/4475B

Contents

Overview	3
Operation	3
Adjustment	3
How to Order	4
Dimensions	5
Specification	7
Maintenance and Service Parts	8
Contact	9

High Temperature Valves - Models 4075D/4475B

Overview

The 4075/4475 high temperature valve is used to sense gas or liquid high temperature conditions. The field adjustable temperature setting from 54°C to 260°C (130°F to 500°F) provides wide setpoint flexibility.

The standard thermowell provides extended life of the sensor and simplifies calibration and maintenance.

Operation

The 4075/4475 is widely used for sensing high pressure natural gas compressor discharge temperature. When a valve is positioned at each compressor cylinder discharge manifold, an increase in temperature past the valves set point will cause the valve to vent off a control signal.

Removal is quick and easy with the stainless steel thermowell which is supplied as part of the standard valve assembly. The valve assembly is held into the well by straight thread connections and a locking nut. Unscrewing the valve body/locknut and disconnecting the tubing fittings is all that is required to remove the valve from the well.

The bi-metallic temperature sensing discs arranged in a stack deflect uniformly as the temperature increases providing a long life, low maintenance actuator for the valve spool.

When the temperature of the fluid flowing past the well is below the tripping point, the temperature sensing element assembly is contracted and the loading spring keeps the valve spool in closed position. If the fluid temperature increases, the bi-metallic element assembly expands, moving the valve spool downward (opening valve) against the springs and opening the IN to the VENT port.

Adjustment

Refer to cut-away view on page 8. This model is checked at the factory for proper operation in a still air calibrating oven at approximately 150°C (300°F). To set the unit on the job to suit operating conditions, it should be piped into the safety control systems and be operational.

The master safety control shut off valve should be overridden during adjustments so the machine will continue running.

- 1)** First remove cap ⑭ by pulling upward. It is held in position by a groove in the cap.
- 2)** Gradually lower the setting by holding the flats of rod ⑤ firmly with a small adjustable wrench, and turning locknut ⑩ clockwise until the safety control indicator registers a trip.
- 3)** Turn locknut ⑩ a turn or so counterclockwise, depending on the temperature rise desired for shutdown above the normal operating temperature.

- 4)** One complete turn of the locknut ⑩ adjusts the temperature 25 to 35°F. Nut ⑩ should be turned sufficiently to effect a bubble-tight seal at the VENT port under normal operating conditions.
- 5)** After adjustment, check to see that the unit operates by manually pushing down on the top of rod ⑤ (observing the shutdown indicator for that function).
- 6)** If the recommended setting procedure is not possible, setting can be done using a pressure gauge in the VENT port, and turning adjusting nut ⑩ until the valve cracks open, giving a gauge reading.

High Temperature Valves - Models 4075D/4475B

How to Order

Use the table below to select the unique specification of your Model 4075D/4475B High Temperature Valve.

Example	4075D	1	01	-AA	Code description				Comments		
					Model (A)						
Model (A)	4075D				Anodised aluminum						
	4475B				316 Stainless steel						
					Body thread (B)						
Body thread (B)		1			NPT				4075D Only		
		0			NPT				4475B ONLY		
					Thermowell (C)						
					Thread	Material S.S. class	Installed depth (L)		Max. pressure		
							inch	mm	psi	bar	
Thermowell (C)			01		¾" NPT	416	3 ¾"	95.3	5,500	379	4075D ONLY
			02		¾" NPT	416	5 ¾"	146.1	5,500	379	
			03		1" NPT	416	3 ¾"	95.3	10,000	689	
			04		1" NPT	416	5 ¾"	146.1	10,000	689	
			05		¾" NPT	326S36	3 ¾"	95.3	3,750	258	
			06		¾" NPT	326S36	5 ¾"	146.1	3,750	258	
			07		1" NPT	326S36	3 ¾"	95.3	6,000	413	
			08		1" NPT	326S36	5 ¾"	146.1	6,000	413	
			11		¾" BSP (PL)	326S36	3 7/16"	87.3	3,750	258	
			12		¾" BSP (PL)	326S36	5 7/16"	138.1	3,750	258	
			13		1" BSP (Tr)	326S36	3 ¾"	95.3	6,000	413	
			14		1" BSP (Tr)	326S36	5 ¾"	146.1	6,000	413	
			31		¾" NPT	316 S.S.	3 ¾"	95.3	3,750	258	4475B ONLY
			32		¾" NPT	316 S.S.	5 ¾"	146.1	3,750	258	
			33		1" NPT	316 S.S.	3 ¾"	95.3	6,000	413	
			34		1" NPT	316 S.S.	5 ¾"	146.1	6,000	413	
			35		¾" BSP (PL)	316 S.S.	3 ¾"	95.3	3,750	258	
			36		¾" BSP (PL)	316 S.S.	3 7/16"	87.3	3,750	258	
			37		¾" BSP (Tr)	316 S.S.	3 ¾"	95.3	3,750	258	
			38		¾" BSP (Tr)	316 S.S.	5 ¾"	146.1	3,750	258	
			39		1" BSP (Tr)	316 S.S.	3 ¾"	95.3	6,000	413	
		40		1" BSP (Tr)	316 S.S.	5 ¾"	146.1	6,000	413		
		41		½" NPT	416	3 ¾"	95.3	10,000	689	4075D ONLY	
		42		½" NPT	416	5 3/8"	136.5	10,000	689		
		43		½" NPT	416	6"	152.4	10,000	689		
					Special requirements (D)						
Special requirements (D)				-AA	Standard						
				-***	Made-to-order						

High Temperature Valves - Models 4075D/4475B

Dimensions Continued

1/2" NPT thermowell thread

Dimensions - inches (mm)

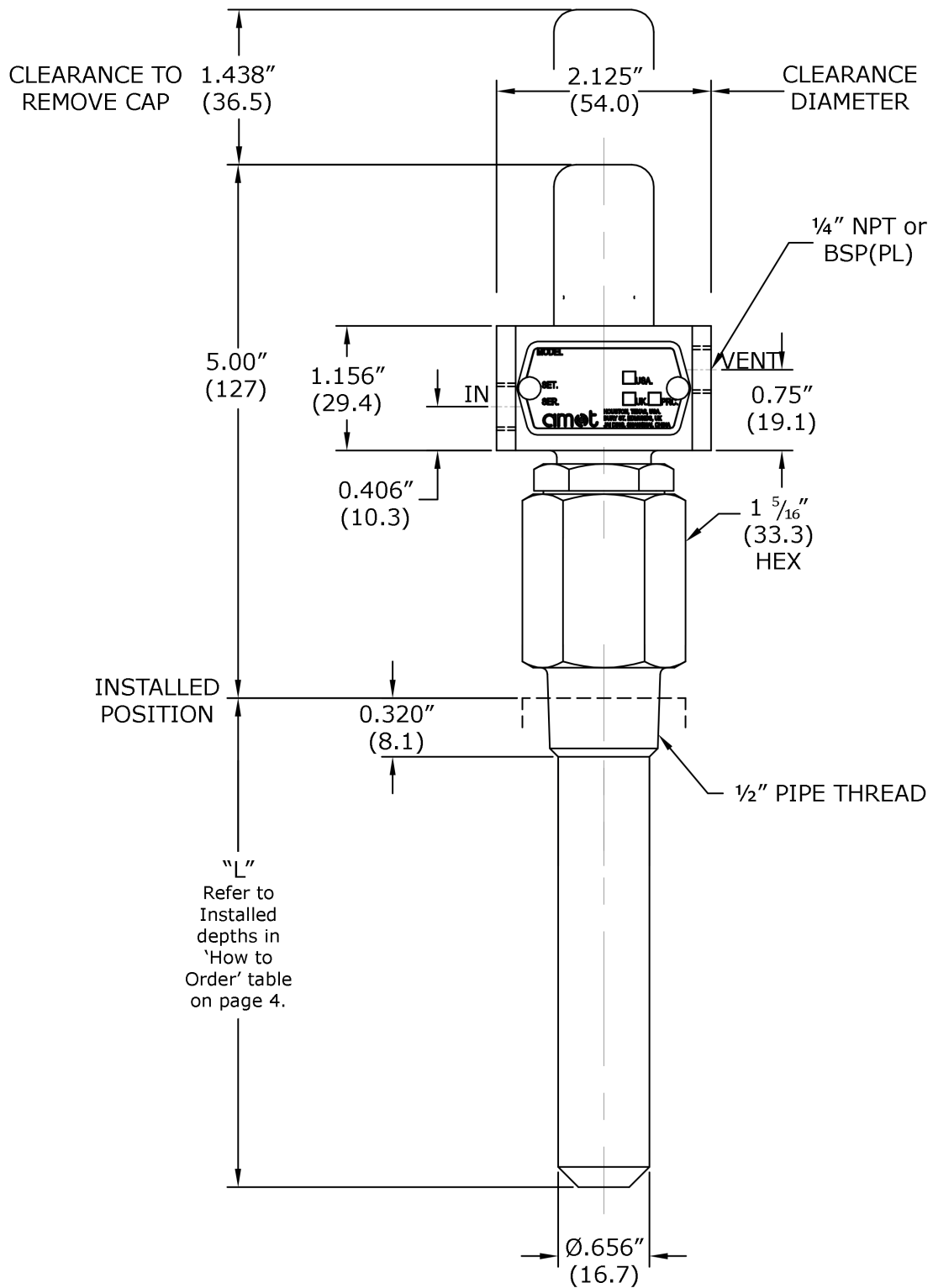

High Temperature Valves - Models 4075D/4475B

Specification

	Metric units	English units
Valve body		
4075D	Anodised aluminum	
4475B	316 Stainless steel	
Valve well	Stainless steel	
Standard seals	Viton	
Sensor type	Bi-metallic disc	
Installation threads		
4075D	3/4" BSP (PL), 3/4" NPT, 1" NPT	
4475B	3/4" BSP (PL), 3/4" BSP (Tr), 3/4" NPT, 1" NPT	
Port threads	1/4" NPT	
Typical medium sensed	Gases	
Adjustable temperature trip range	54°C - 260°C	130°F - 500°F
Maximum allowable sensed temperature	260°C	500°F
Maximum pressure at IN port	8.62 bar	125 psi
Net weight (depended on well type selected)		
4075D	0.5 - 0.6 kg	1.1 - 1.3 lbs
4475B	0.7 - 0.8 kg	1.5 - 1.8 lbs

High Temperature Valves - Models 4075D/4475B

Maintenance and Service Parts

Over time, exposure to foreign chemicals and particulate matter as well as prolonged operation at extreme conditions may reduce the effectiveness of the valve. At such time, AMOT High Temperature Valves can be restored to original performance by replacing the service parts. Service parts for AMOT High Temperature Valves include discs, seals and seal components required for normal maintenance. Please order service parts using the part numbers, quantities and descriptions given in the service parts table below.

AMOT designs and tests all its products to ensure that high quality standards are met. For good product life, carefully follow AMOT's installation and maintenance instructions; failure to do so could result in damage to the equipment being protected or controlled.

AMOT recommends a service interval of 12 months to ensure optimum valve performance.

Service parts					
Ref no.	Part no.	Qty.	AMOT part description	Valve part number restrictions	Comments
4	395L009	3	Oring, Viton	NONE	
9	9385	34	Disc	Thermowell (C) ≠ 41,42,43	
	9889	48	Bi-metallic disc	Thermowell (C) = 41,42,43	
10	534	1	Locknut, 10-32 LT HX flex cad	NONE	USA/Canada ONLY
	40884	1	Locknut, 10-32 UNF, black	NONE	Europe/Asia-PAC ONLY
14	9513L001	1	Cap - plated	Model (A) = 4075D	
BP	21721L001	1	Krytox GPL296 grease	NONE	
-	ISB-4075-4475-001	1	4075D/4475B Installation and Service Bulletin	NONE	

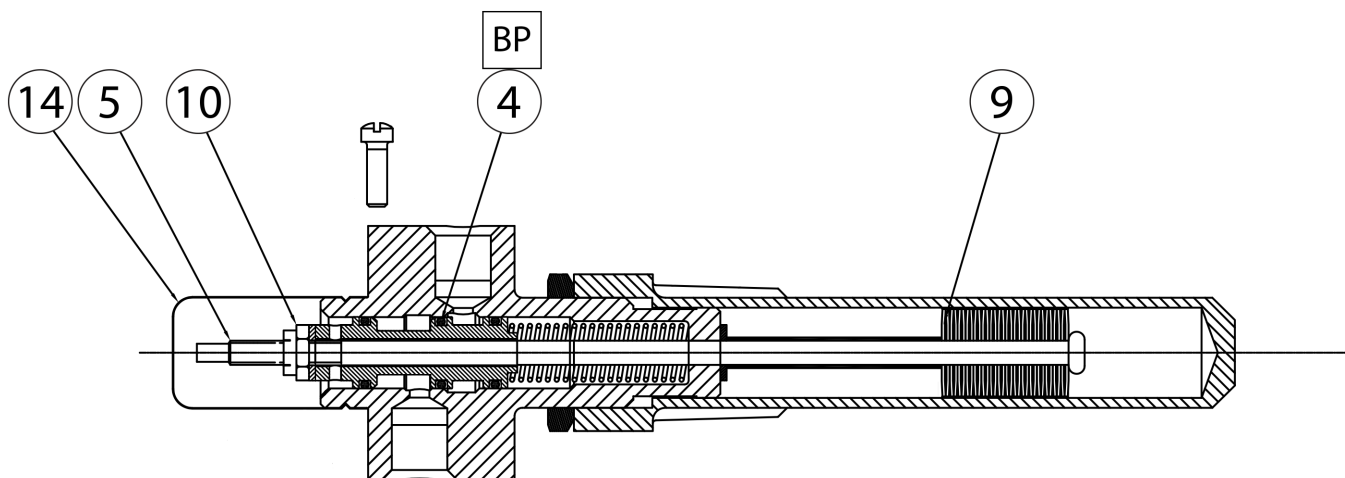

High Temperature Valves - Models 4075D/4475B

Contact

Americas

AMOT USA
8824 Fallbrook Dr.
Houston, TX 77064
USA

Tel: +1 (281) 940 1800
Fax: +1 (713) 559 9419
Email: customer.service@amot.com

Europe, Middle East and Africa

AMOT UK
Western Way
Bury St. Edmunds
Suffolk, IP33 3SZ
England

Tel: +44 1284 715739
Fax: +44 1284 760256
Email: info@amot.com

AMOT Germany
Rondenbarg 25
22525 Hamburg
Germany

Tel: +49 40 8537 1298
Fax: +49 40 8537 1331
Email: germany@amot.com

Asia Pacific

AMOT Shanghai
Bd. 7A, No. 568, Longpan Rd., Malu Jiading
Shanghai 201801
China

Tel: +86 21 5910 4052
Fax: +86 21 5237 8560
Email: shanghai@amot.com