

Differential Pressure Valve

Model 4143A

Typical applications

- Protection of engines and other industrial equipment in case of water circulation slow down or failure.

Key features and benefits

- Senses:
 - Coolant loss
 - Excessive aeration
 - Worn pump impeller blades
 - Loss of pump priming pressure
 - Water pump failure
- Gulfproof, anodized aluminum construction

Accreditations available

- ATEX  II 2G c IIC X



Model 4143A
Differential Pressure Valve

Differential Pressure Valve - Model 4143A

Contents

Overview	3
Operation	3
Installation Factors	3
Adjustment	4
How to Order	4
Specification	4
Dimensions	5
Maintenance and Service Parts	5
How to order service kits	5
Service parts	6
Contact	7

Differential Pressure Valve - Model 4143A

Overview

AMOT Model 4143 valve is used for sensing loss of coolant due to hose breakage, poor water flow due to excessive cavitation or worn pump impeller blades.

Upon a dangerous condition, the pressure differential will decrease, causing the valve to vent the lubricating oil pressure supply line to the AMOT 2800 Master Safety Control, causing it to trip and shutdown the engine.

Operation

When the valve is used for sensing loss of pump priming pressure, run a line from the pressure outlet of the pump to Valve Port P2, and allow Port P1 to be vented to atmosphere.

It senses the pressure difference between each side of the water pump. This valve is "Gulfproofed" (corrosion protection for seacoast atmospheres).

Installation Factors

AMOT designs and tests all products to ensure that high quality standards are met. Carefully follow AMOT's installation and maintenance instructions; failure to do so could result in damage to equipment being protected.

The installation should be made according to the typical installation diagram below, cut-away view on page 5, and the following instructions:

- 1) The 4143 valve should be mounted at the highest practical point in the water system, preferably above the water line to prevent contaminants from entering the valve.
- 2) Remove the loosely fitted seal wire ⑬, and store for use after valve adjustment (see the Adjustment section on page 4).
- 3) Fasten the valve using the two mounting holes provided to a secure surface or bracket.
- 4) Connect the supply line to the "IN" port using a quality thread sealant such as Loctite™ Pipe Sealant to the pipe thread connections – 6.2 bar (90 psi) maximum.
- 5) Connect the "VENT" port depending on the type of control medium.
 - Air – no connection is required but it should be protected from contamination by a suitable vent closure such as the AMOT 4125B or a tubing elbow bent downwards.

- Oil – connect to the sump.
 - Gas – connect to system vent.
- 6) Connect the lines containing the fluid to be sensed to Ports P1 and P2 using a quality thread sealant such as Loctite™ Pipe Sealant to the pipe thread connections – 4.1 bar (60 psi) maximum.
 - 4143 Valve Port stamped P2 is piped to water pump discharge. Port stamped P1 is piped to water pump suction.
 - 7) Upon installation, the desired set point should be obtained by correct adjustment of the valve. Refer to the Adjustment section on page 4.

CAUTION: Do not turn or move valve body ⑳ as this setting. If valve body must be removed, readjust as follows:

- 1) Turn adjusting screw ⑪ in half way. With air pressure at the valve body IN port, screw the valve body in until it just starts to vent.
- 2) Screw in 1 full turn and tighten lock nut ㉔.
- 3) Functionally test to assure that the valve vents with no pressure at P2 and seals when there is pressure at P2.

Typical installation diagram

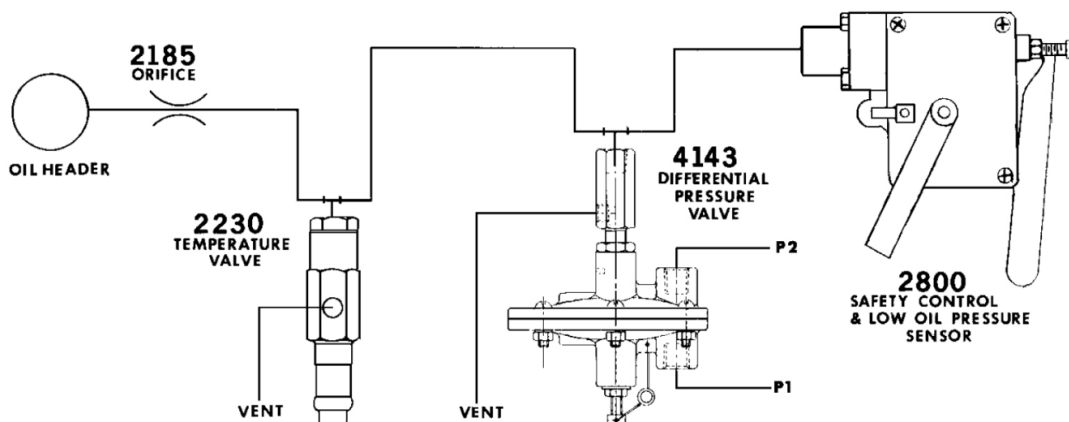

Differential Pressure Valve - Model 4143A

Adjustment

- 1) Ensure engine is running at low idle speed.
 - 2) Loosen nut ⑭ securing the adjusting screw ⑪.
 - 3) Turn the adjusting screw slowly clockwise until the engine shuts down.
 - One turn of the adjusting screw changes the setting approximately 0.07 bar (1 psi).
 - 4) Turn the adjusting screw approximately one-half turn counter-clockwise.
 - 5) Retighten the securing nut to hold the set-point.
 - 6) Restart the engine several times ensuring correct function. Repeat steps 2 to 5 as necessary to ensure the correct setting is achieved.
 - 7) Thread the seal wire ⑬ through the hole in the diaphragm cover ⑧, and thread the loose end through the seal. Carefully unravel the paired wire from the loose end up to the seal, and thread one end through the hole in the adjusting screw head ①.
 - 8) Using a pair of pliers, twist the unraveled wire back together. Finally, pass the paired wire back through the seal, and using a pair of pliers, squeeze the seal to lock the wire in place. Any excess wire may be removed using suitable wire cutters.
- CAUTION:** Do not turn or move valve body ⑳ as this setting. If valve body must be removed, readjust as follows:
- Turn adjusting screw ⑪ in half way. With air pressure at the valve body IN port, screw the valve body in until it just starts to vent.
 - Screw in 1 full turn and tighten lock nut ㉔.
 - Functionally test to assure that the valve vents with no pressure at P2 and seals when there is pressure at P2.

How to Order

Use the table below to select the unique specification of your 4143A Differential Pressure Valve.

USA Example	4143A	001		Code description	Certification	Comments
UK Example	4143A	001	-AA			
				Basic model (A)		
Basic model (A)	4143A					
				Thread type (B)		
Thread type (B)		001		NPT		
				Suffix code (C)		
Suffix code (C)			'blank'	Standard	None	USA ONLY
			-AA	Standard	ATEX	UK ONLY
			-AAA	Black epoxy coated	None	

Specification

	Metric units	English units
Housing material	Aluminum	
Diaphragm material	Buna N/Nitrile	
Maximum pressure on diaphragm	4.1 bar	60 psi
Adjustable differential pressure range	0.0345 - 0.25 bar @ 0.69 bar	0.5 - 3.6 psi @ 10 psi
Reset differential	0.014 ± 0.0069 bar	0.6 ± 0.1 psi
Maximum pressure at valve "IN" port	6.2 bar	90 psi
Net weight	0.57 kg	1.25 lbs

Differential Pressure Valve - Model 4143A

Dimensions

Dimensions - mm (inches)

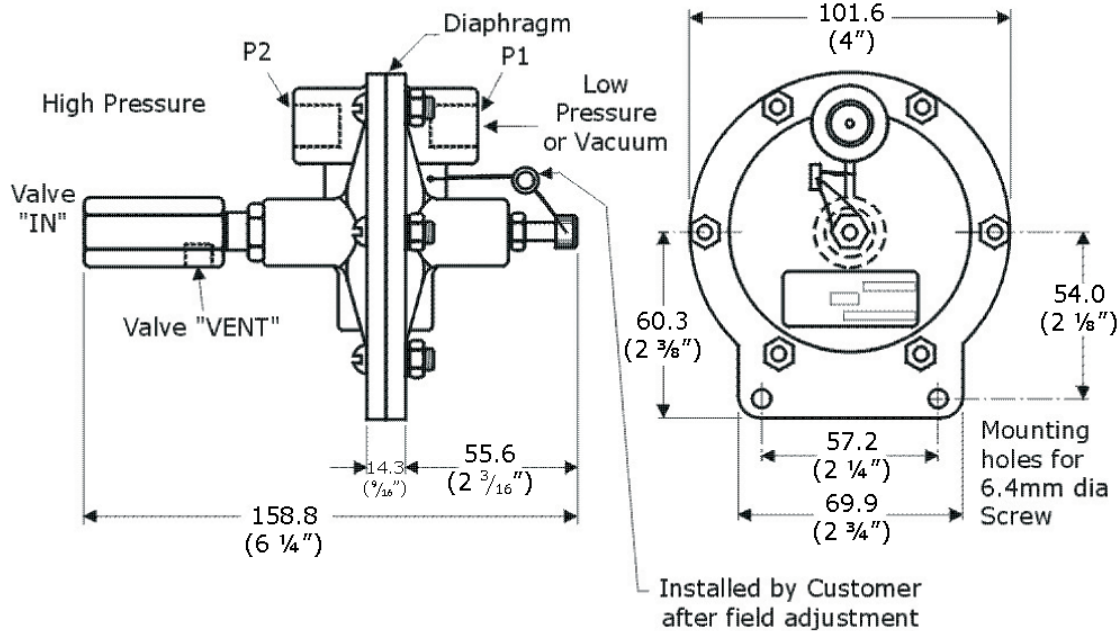

Maintenance and Service Parts

Over time, exposure to foreign chemicals and particulate matter as well as prolonged operation at extreme conditions may reduce the effectiveness of the valve. At such time, AMOT Differential Pressure Valves can be restored to original performance by installing an AMOT differential pressure valve service kit. Service kits include all new seals and seal components required for normal maintenance.

For Model 4143A001-AA:

- To satisfy the ATEX requirements, the external surface of the Valve must be cleaned on a regular basis to prevent the accumulation of potentially flammable dirt/spillages. A damp cloth, or dry anti-static cloth must be used for this purpose.
- To satisfy the ATEX requirements, inspection of all serviceable parts is mandatory and must be performed on a regular **6 monthly** basis.
- Damage found to any serviceable parts must be replaced immediately.

How to order service kits

Service kits are available with seal parts required to service the valve. All 4143A Differential Pressure Valves have the same service kit **9117X**.

AMOT recommends the replacement of all serviceable parts on a regular 12 monthly basis.

Where the control medium is flammable, the valve must be inspected at weekly intervals for leaks to minimize the risk of explosion. AMOT designs and tests all its products to ensure that high quality standards are met. For good product life, carefully follow AMOT's installation and maintenance instructions; failure to do so could result in damage to the equipment being protected or controlled.

To satisfy ATEX requirements, the nameplate must be replaced on reassembly. Please contact AMOT to order a new nameplate.

Differential Pressure Valve - Model 4143A

Maintenance and Service Parts Continued

Service parts

Service kit parts		
Ref no.	Qty.	Description
2	1	Seal washer
4	1	Diaphragm
7	1	Piston seal
12	1	Seal
13	1	Seal wire
22	1	Pushrod seal

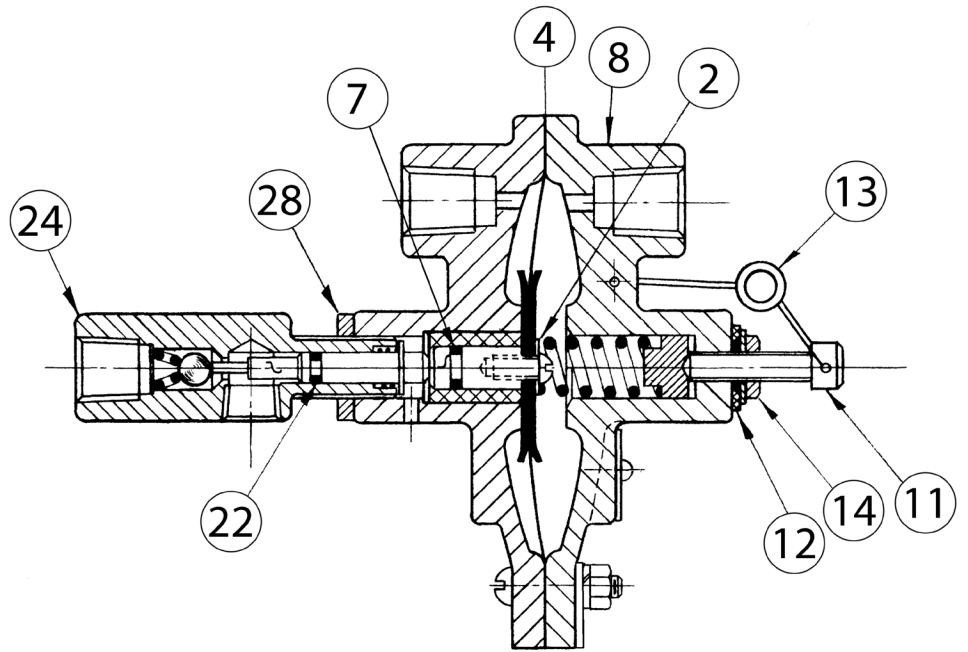

Differential Pressure Valve - Model 4143A

Contact

Americas

AMOT USA
8824 Fallbrook Dr.
Houston, TX 77064
USA

Tel: +1 (281) 940 1800
Fax: +1 (713) 559 9419
Email: customer.service@amot.com

Asia Pacific

AMOT Shanghai
Bd. 7A, No. 568, Longpan Rd., Malu Jiading
Shanghai 201801
China

Tel: +86 21 5910 4052
Fax: +86 21 5237 8560
Email: shanghai@amot.com

Europe, Middle East and Africa

AMOT UK
Western Way
Bury St. Edmunds
Suffolk, IP33 3SZ
England

Tel: +44 1284 715739
Fax: +44 1284 760256
Email: info@amot.com

AMOT Germany
Rondenbarg 25
22525 Hamburg
Germany

Tel: +49 40 8537 1298
Fax: +49 40 8537 1331
Email: germany@amot.com

 **WARNING**

These products can expose you to chemicals including carbon black (airborne and extracts), antimony trioxide, titanium dioxide, silica (crystalline), di(2-ethylhexyl)phthalate, ethylene thiourea, acrylonitrile, 1,3-butadiene, epichlorohydrin, toluenediisocyanate, tetrafluoroethylene, ethylbenzene, formaldehyde, furfuryl alcohol, glass fibers, methyl isobutyl ketone, nickel (metallic and compounds), lead and lead compounds which are known to the state of California to cause cancer; and 1,3 butadiene, epichlorohydrin, di(2-ethylhexyl)phthalate, di-isodecyl phthalate, ethylene thiourea, methyl isobutyl ketone, toluene, lead and lead components which are known to the state of California to cause birth defects and other reproductive harm. For more information go to www.P65Warnings.ca.gov.