

3-Way Temperature Control Valve

Model G, Version G and Accessories

Typical applications

For engines, turbines, gearboxes and heat exchangers:

- Charge air cooling
- Secondary cooling systems
- Fuel and lube oil preheating
- Co-generation
- Engine jacket water

For refineries, chemical plants and oil reproduction:

- Waste heat boilers
- Product coolers
- Product heaters
- Product condensers

Key benefits

- Ease of integration - valve size matches pipe size, resulting in reduced installation time and installation costs
- Flexible design - ports can be configured to suit installation
- Low pressure drop - compared to other valve types
- Small physical size
- Hand wheel allows manual adjustment of valve (optional on pneumatic valve)
- Simplified set up and maintenance



**Electric
GG Valve**



**Pneumatic
GG Valve**

Even more compact

GG Valve vs typical equivalent competitor's specification.

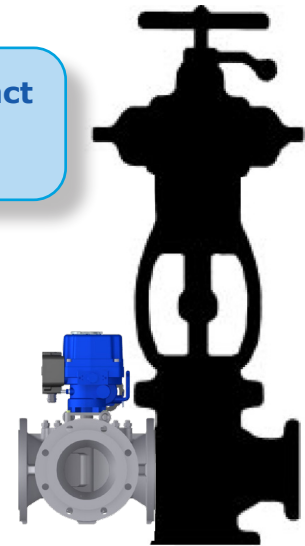

amot

www.amot.com

3-Way Temperature Control Valve - Model G, Version G

Contents

Overview	3
Applications	3
System Types (Electric)	4
System Types (Pneumatic)	5
Overview of the Valve Body	6
Valve Dimensions	7
G Valve Body	8
Modes of Operation	8
Valve Sizing	9
Valve Flowrate Selection: Flowrate m ³ /hr (USg/m)	9
Viscosity Correction	10
Viscosity Correction Curve	10
SAE Oil Viscosities	10
Valve Sizing Calculations	11
Valve Flowrate	11
Pressure Drop	11
Valve Bypass Flowrates	11
Overview of Electric Actuation	12
Overview of Pneumatic Actuation	13
Actuator Dimensions	14
EB Actuator.....	14
EA Actuator.....	15
EC Actuator	16
EC050	16
EC100	17
EH Actuator	18
Pneumatic Actuator	19
How to Order	20
Accessories	21
PID Valve Controllers	22
3-Wire PT100 Temperature Sensor – 8060	22
Solid State Relay Module – 8070C	23
Electro-Pneumatic Converter – 8064A	23
Electro-Pneumatic Converter – 8064C	24
Pneumatic Indicator Controller – SG80	24

3-Way Temperature Control Valve - Model G, Version G

Overview

AMOT G valves are 3-way control valves consisting of a heavy-duty rotary valve and either a quarter turn electric or pneumatic actuator. The valves provide a high degree of accuracy and repeatability for accurate temperature control and are equally accurate in mixing or diverting service over a wide flow range.

The heavy-duty rotor design provides tight temperature control without high maintenance requirements. The system is available in three standard control configurations: electric; pneumatic; and electro-pneumatic, offering flexibility for most requirements.

Some actuator options are designed and reinforced for vibration service and are qualified to Lloyd's Marine Requirements for shipboard service. Certain G Valve and actuator combinations can be directly mounted to reciprocating machinery such as diesel engines, without vibration isolation.

Standard G Valves are suitable for a variety of fluids such as water, water/glycol, sea water, lubricating and hydraulic oils. Optional body materials are available for services involving synthetic or fire resistant oils, deionized water and ammonia or freon in oil.

Applications

Mixing Applications

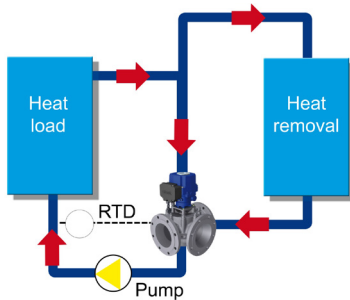

Lubricating oil temperature control is normally configured in a mixing application controlling the return temperature to the heat load. The temperature is normally measured as close as possible to the sump return.

Diverting Applications

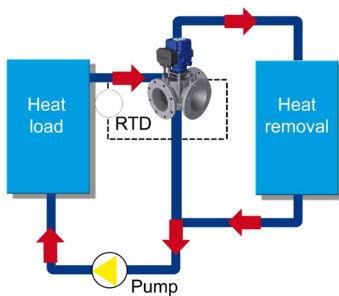

Jacket water cooling in diverting applications regulates the outlet coolant water temperature from a diesel or gas engine. The valve either sends water to a cooler or bypass loop, accurately maintaining the temperature.

The temperature is normally measured at the outlet from the heat source.

Charge Air Temperature Control

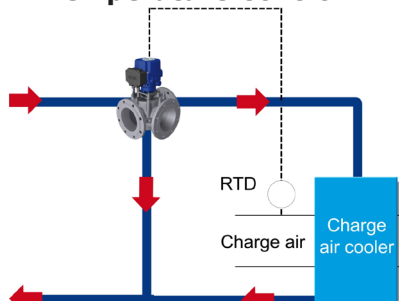

The intercooler is used to cool high temperature turbo charger air.

In this application the G Valve regulates the flow of cooling water through an intercooler, increasing efficiency, enhancing performance and helping to meet today's environmental requirements.

3-Way Temperature Control Valve - Model G, Version G

System Types (Electric)

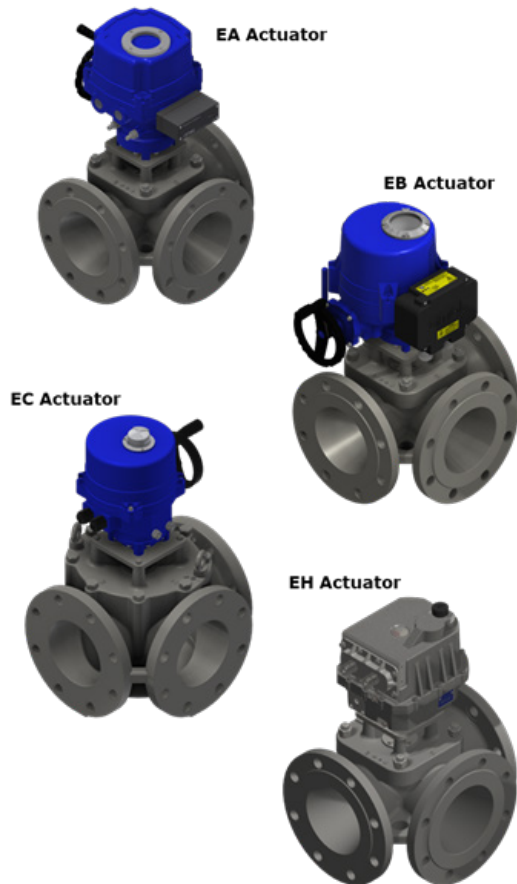

For the electrically operated valves, a number of actuator options are available, which use an electric motor that rotates in either direction in response to the ON-OFF signals received. The motor drives a gearbox connected to the rotor shaft and turns the valve rotor clockwise or counter-clockwise, a maximum of 90 degrees. At the end of travel, limit switches are incorporated to isolate the electrical supply to the motor when the valve rotor has reached either end of the rotation. A feedback hall sensor is available on some actuators, providing position indication to the control system.

Most actuators are powered by an electric motor driving a worm-type gearbox. The worm gearbox prevents reverse drive due to the forces generated by fluid flow.

A thermal cutout is fitted preventing overheating. Limit switches at each end of stroke disconnect motor power when end stroke is reached. These can also be used for remote indication.

See page 12 for more information on the electric actuator options.



A typical electric valve system incorporates an electrically actuated three-way control valve with an electronic controller and temperature probe. The 8071D PID Controller can be either panel or wall mounted (see page 21 for more information). The system is completed with a temperature sensor type 8060 (see page 21 for details).

The electric G Valve system is simple to install with standard multicore cable and provides more accurate measurement and control than typical pneumatically operated systems.

3-Way Temperature Control Valve - Model G, Version G

System Types (Pneumatic)

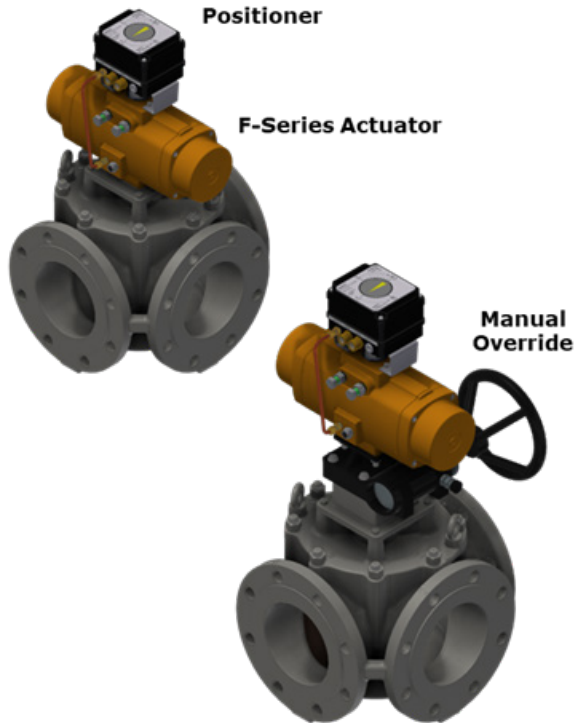

The pneumatic valve uses a spring return pneumatic actuator and positioner to control the rotation of the valve in response to an input signal for a pneumatic or electro-pneumatic control system. The pneumatic control system sends a pneumatic signal ranging from 0.21 to 1.03 bar (3 to 15 psi) to the actuator to correctly position the valve rotor to achieve the correct system temperature. The pneumatic control system usually consists of a P+I pneumatic controller, sensor and the necessary air supply conditioning equipment (regulators, filters and water traps).

The pneumatic actuator is a rugged, quarter turn, double piston actuator operating on a scotch yoke principle.

The actuator is fitted with spring return as standard allowing fail-safe configuration if necessary. It is also fitted with a valve positioner enabling accurate and repeatable movement. See page 13 for more information on the pneumatic actuator.

Pneumatic System

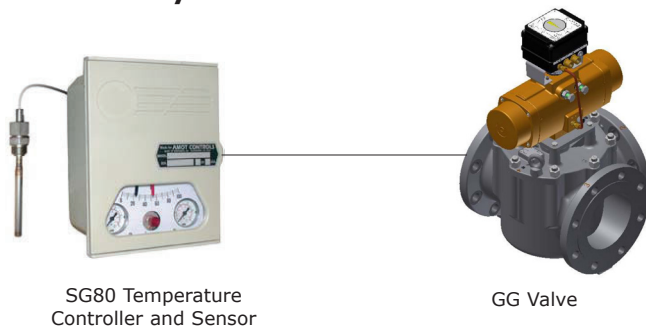

The pneumatic valve system incorporates a pneumatically actuated three-way control valve with controller and integral temperature sensor, the SG80, which can be panel or wall mounted. For more information on the SG80, see page 23. The pneumatic G valve system is ideal when there is a lack of electricity or when a fail-safe system is needed.

Electro-Pneumatic System

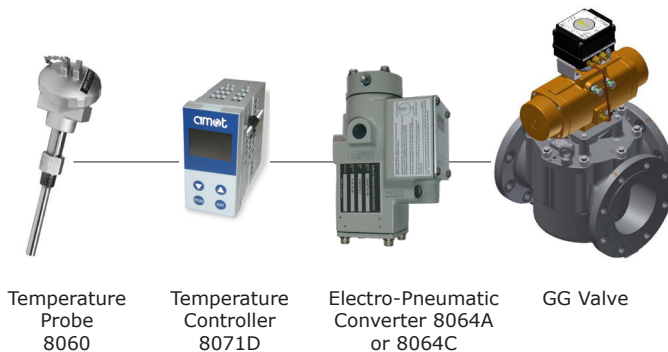

The electro-pneumatic valve system combines both electric and pneumatic technology, consisting of a pneumatically actuated three-way control valve with an electro-pneumatic converter, type 8064A (where available) or type 8064C. See pages 22 and 23 for more details.

The probe sends a resistance signal to the electronic controller, which in turn sends a 4 to 20mA signal to an I/P converter that converts this to a pneumatic signal.

The electro-pneumatic system combines the features and functionality of the AMOT electronic control system with the fail-safe action benefits of a pneumatically actuated valve.

3-Way Temperature Control Valve - Model G, Version G

Overview of Valve Body Assembly

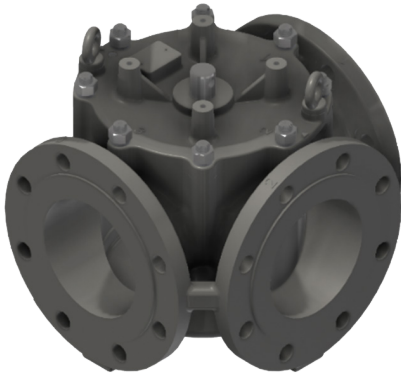

Key features and benefits

- Lightweight and compact
- Configurable ports - allowing flexibility on installation
- Low pressure drop - enables savings on either valve or pump size
- High accuracy providing better temperature control

Specification

Flow To		720m ³ /hr (3,170 US gpm)			
Sizes		Standard Flow		High Flow	
		65mm-250mm (2.5"-10")		15mm-200mm (0.5"-8")	
Comments		For DN250 (10") High Flow and above, see Datasheet GEF_GPD_Temp_Control_Valve			
Body Materials		Ductile iron	Bronze & Aluminium Bronze	Steel	Stainless Steel
Temp. Range	Min Fluid Temp	-10°C (14°F)	-40°C (-40°F)	-10°C (14°F)	-40°C (-40°F)
	Max Fluid Temp	+100°C (212°F)*			
Comments		*For higher temperature variants, contact AMOT			
Seal Materials		Fluorocarbon (Viton/FKM)	Nitrile (NBR)	AFLAS (TFE/P)	EPDM
Compatibility	Water (≤80°C/176°F)	✓	✓	✓	✓
	Hot Water (>80°C/176°F)	X	X	✓	✓
	Water/Glycol	✓	✓	✓	X
	Oils (Synthetic Based)	✓	X	X	X
	Oils (Petroleum Based)	✓	✓	X	X
Temp. Range	Min Fluid Temp	-15°C (23°F)	-30°C (-22°F)	+10°C (50°F)	-45°C (-49°F)
	Max Fluid Temp	+180°C (356°F)	+80°C (176°F)	+180°C (356°F)	+100°C (212°F)
Comments		Customer to confirm material / fluid compatibility			
Maximum Internal Valve Pressure		Ductile Iron, Bronze & Al. Bronze		10 Bar (145 psi)	
		0.5"-4" Steel & Stainless Steel		16 Bar (232 psi)	
		6" and above Steel & Stainless Steel		15 Bar (218 psi)	
Comments		Maximum internal valve pressure may be less depending on the flange connection option chosen. Contact AMOT for confirmation of pressure rating.			
Maximum System Differential Pressure		Standard Valves		Class II Valves	
		5 bar (73 psi)		1 bar (15 psi)*	
Comments		*For higher differential pressure options, contact AMOT			

3-Way Temperature Control Valve - Model G, Version G

Valve Dimensions

G Valve Body

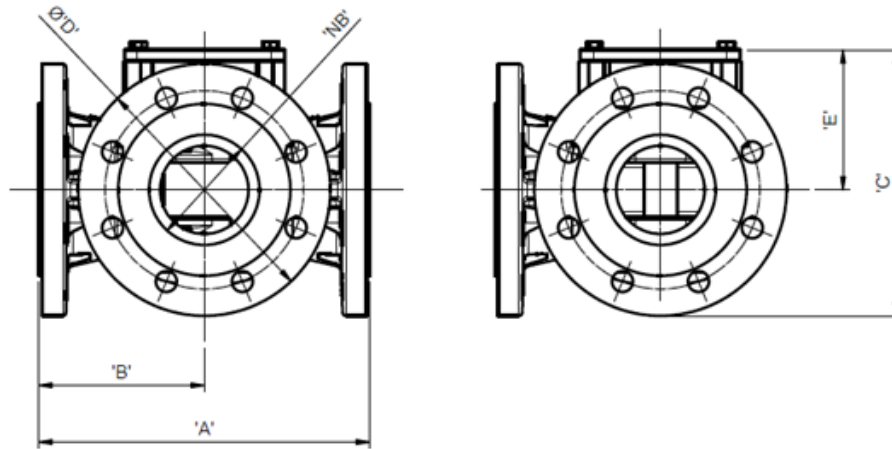

Valve Type	Valve Body (Dimensions in mm)					
	NB	A	B	C	D	E
0.5GGH	15	178	89	133	95	86
0.75GGH	20			138	105	
01GGH	25			148	125	
02GGH	50	230	115	173	165	91
2.5GGS	65			184	185	
03GGS	80	280	140	191	200	117
03GGH				217	200	
04GGS	100	300	150	232	229	
04GGH				271	224	
05GGS	125	340	170	286	254	159
06GGS	150	370	185	302	285	181
06GGH				336	285	
08GGS	200	450	225	361	343	
08GGH				408	340	
10GGS	250	520	260	445	406	225

Valve Type	Valve Body (Dimensions in Inches)					
	NB	A	B	C	D	E
0.5GGH	0.5	7.01	3.50	5.24	3.74	3.39
0.75GGH	0.75			5.43	4.13	
01GGH	1			5.83	4.92	
02GGH	2	9.06	4.53	6.81	6.50	3.58
2.5GGS	2.5			7.24	7.28	
03GGS	3	11.02	5.51	7.52	7.87	4.61
03GGH				8.54	7.87	
04GGS	4	11.81	5.91	9.13	9.02	
04GGH				10.67	8.82	
05GGS	5	13.39	6.69	11.26	10.00	6.26
06GGS	6	14.57	7.28	11.89	11.22	7.13
06GGH				13.23	11.22	
08GGS	8	17.72	8.86	14.21	13.50	
08GGH				16.06	13.39	
10GGS	10	20.47	10.24	17.52	15.98	8.86

3-Way Temperature Control Valve - Model G, Version G

Modes of Operation

		Rotor Position	
		Start	End
Mode 32			
Mode 21			
Mode 12			
Mode 23			
Mode 13			
Mode 31			

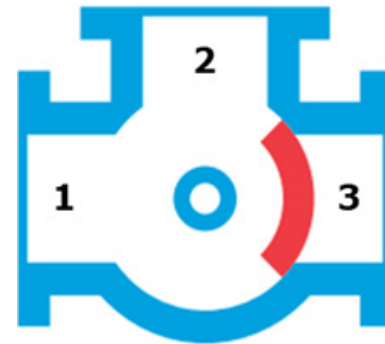

Port Number Diagram

The unique construction of the AMOT G Valve provides total flexibility by allowing valve port position selections to most ideally suit application requirements. There are two main types of mode of operation: 90° rotor that allows either ports 1 or 3 to be selected as the common port; and 180° rotor that requires port 2 to be the common port.

For electrically actuated valves, the 'Start' and 'End' positions indicate valve movement with a change in input signal, as viewed from above (see diagram). On loss of signal the actuator is set up by default to stop in its current position.

For pneumatically actuated valves, the 'Start' and 'End' positions indicate valve movement with a change in input signal, as viewed from above (see diagram). On loss of signal the actuator is set up by default to return to its 'Start' position.

For 'Start' & 'End' input conditions, see table below.

Rotor Position		Electric		Pneumatic		
		Start	End	Start	End	No Signal
Input	Direct	Low Signal	High Signal	Low Signal	High Signal	Start
	Reverse	High Signal	Low Signal	High Signal	Low Signal	End

3-Way Temperature Control Valve - Model G, Version G

Valve Sizing

Valve Flowrate Selection: Flowrate m³/hr (USg/m)

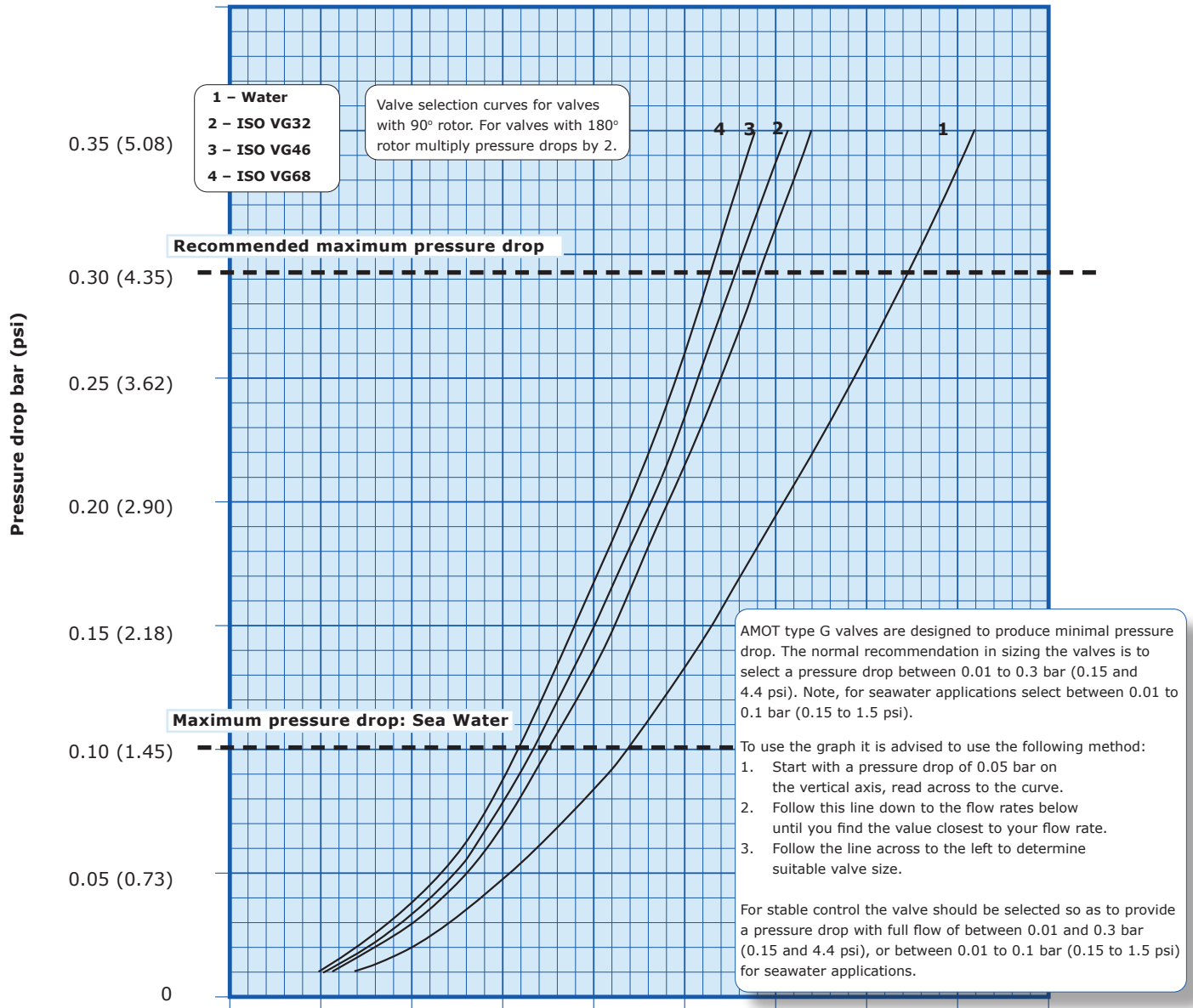

Size DN (Inches)	Flowrate: m ³ /hr (USg/m)		Flowrate: m ³ /hr (USg/m)							
	N/A	15, 20 & 25 (1/2, 3/4 & 1)	TBD	TBD	TBD	TBD	TBD	TBD	TBD	TBD
65 & 80 (2.5 & 3)	50 (2)		7 (31)	14 (62)	20 (88)	26 (114)	33 (145)	39 (172)	46 (203)	52 (229)
100 (4)	80 (3)		19 (84)	35 (154)	51 (225)	67 (295)	83 (365)	99 (436)	115 (506)	131 (577)
125 & 150 (5 & 6)	100 (4)		29 (128)	54 (238)	79 (348)	104 (458)	129 (568)	154 (678)	179 (788)	204 (898)
200 (8)	150 (6)		66 (291)	122 (537)	178 (784)	235 (1035)	291 (1281)	347 (1528)	403 (1774)	459 (2021)
250 (10)	200 (8)		118 (520)	218 (960)	318 (1400)	418 (1840)	517 (2276)	617 (2717)	717 (3157)	817 (3597)
300 (12)	250 (10)									
350 (14)	300 (12)									
400 (16)	350 (14)									
450 (18)	400 (16)									
Standard Flow	High Flow									

Currently only available in GEF/GPD versions.
See Datasheet GEF_GPD_Temp_Control_Valve for data

3-Way Temperature Control Valve - Model G, Version G

Viscosity Correction

Example:

From the graph below:

100 cSt = correction factor of 0.68

$0.68 \times \text{flow coefficient} = \text{corrected flow coefficient (Kv or Cv)}$

Some approximate viscosities (cSt) of SAE oils at 40°C (110°F) are shown below, based on leading oil manufacturers published data.

For the selection of valves for more viscous fluids than water the following must be calculated.

Viscosity: Find the viscosity of the fluid in which the valve is to operate. The viscosity is normally expressed in centistokes. Where ISO oil is used, the grade number is also the viscosity eg ISO VG46 is 46 centistokes at 40°C (104°F).

Viscosity Correction Curve

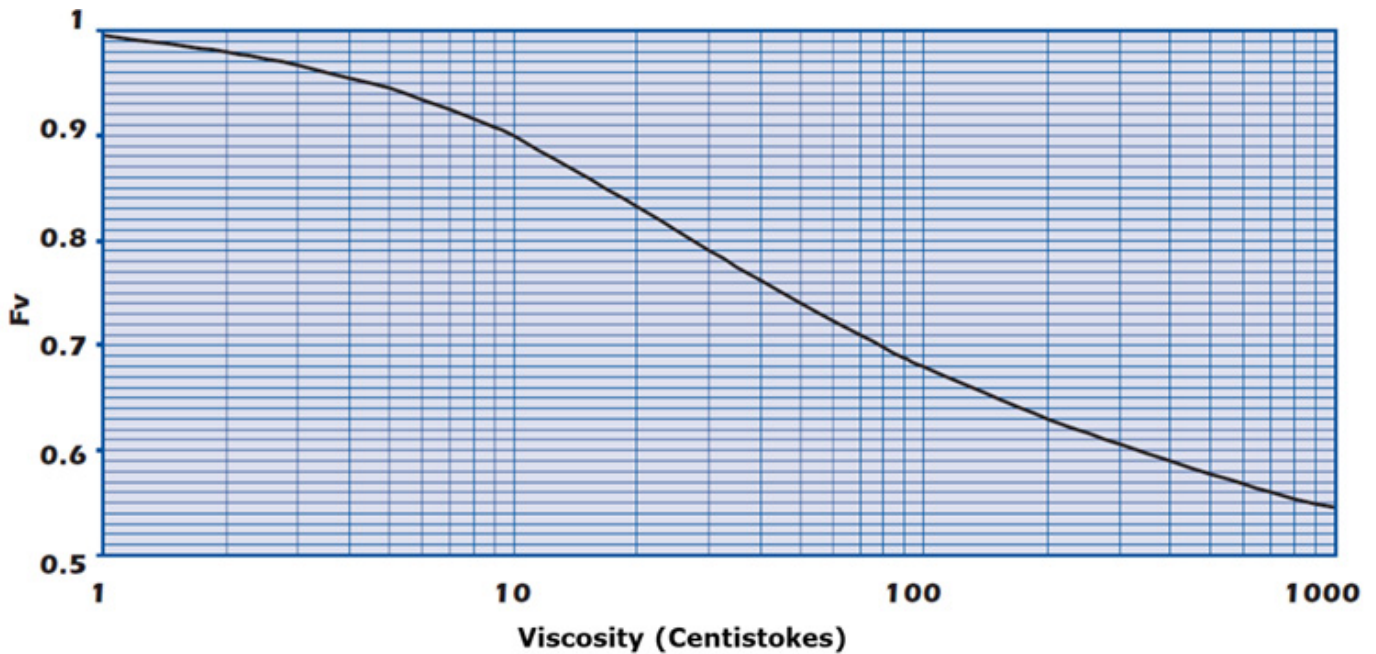

SAE Oil Viscosities

Engine oils	
Oil	cSt
SAE 5W	6.8
SAE 10W	32
SAE 20	46
SAE 20W	68
SAE 30	100
SAE 40	150
SAE 50	220

Gear oils	
Oil	cSt
SAE 75W	22
SAE 80W	46
SAE 85W	100
SAE 90	150
SAE 140	460

Some approximate viscosities (cSt) of SAE oils at 40°C (104°F) are shown alongside, based on leading oil manufacturers' published data.

3-Way Temperature Control Valve - Model G, Version G

Valve Sizing Calculations

Valve Flowrate

See the table below for examples of Kv and Cv:

Size DN (in)	Standard Flow	N/A	N/A	N/A	65 (2.5)	80 (3)	100 (4)	125 & 150 (5 & 6)	200 (8)	250 (10)	300 (12)	350 (14)	400 (16)	450 (18)
	High Flow	15 (1/2)	20 (3/4)	25 (1)	N/A	50 (2)	80 (3)	100 (4)	150 (6)	200 (8)	250 (10)	300 (12)	350 (14)	400 (16)
Kv		7	14	27	112	82	207	323	729	1296	Currently only available in GEF/GPD versions. See Datasheet GEF_GPD_Temp_Control_Valve for data			
Cv		8	16	31	129	96	242	378	851	1513				

Pressure Drop

The G valve is designed to produce minimal pressure drop. The normal recommendation when determining the size of an AMOT G valve is a pressure drop between 0.01 and 0.3 bar (0.15 and 4.4 psi).

Note: For sea water, the valve should be sized for a pressure drop between 0.01 and 0.1 bar (0.15 and 4.4 psi).

Note: Kv and Cv values are applicable to 90° rotor versions only.

Kv is the flow coefficient in metric units. It is defined as the flow rate in cubic meters per hour (m³/h) of water at a temperature of 16° celsius with a pressure drop across the valve of 1 bar. Cv is the imperial coefficient. It is defined as the flow rate in US Gallons per minute [gpm] of water at a temperature of 60° fahrenheit with a pressure drop across the valve of 1 psi. (Kv = 0.865 Cv / Cv = 1.156 Kv)

The basic formula to determine the Kv of a valve is:

$$Kv = Q \sqrt{\frac{SG}{Dp}}$$

Q = Flow (m³/h)
 Dp = Pressure drop (bar)
 SG = Specific gravity of fluid
 Kv = Valve flow coefficient

There are two other ways that this formula can be used to find the flow in m³/h or pressure drop of a valve in bar:

$$Q = Kv \sqrt{\frac{Dp}{SG}} \quad Dp = \left[\frac{Q}{Kv} \right]^2 SG$$

The basic formula to determine the Cv of a valve is:

$$Cv = Q \sqrt{\frac{SG}{Dp}}$$

Q = Flow (US gallons/min)
 Dp = Pressure drop (psi)
 SG = Specific gravity of fluid
 Cv = Valve flow coefficient

There are two other ways that this formula can be used to find the flow in US gallons/minute or pressure drop of a valve in PSI:

$$Q = Cv \sqrt{\frac{Dp}{SG}} \quad Dp = \left[\frac{Q}{Cv} \right]^2 SG$$





Valve Bypass Flowrates

The AMOT G Valve is not a tight shutoff valve. When the standard rotor type is used in a reasonably balanced pressure system there will be some small amounts of leakage between ports. The actual amount of leakage will vary with the pressure difference between these ports.

When reduced leakage is required, the Class II rotor type should be selected, allowing for a maximum leakage of 0.5% of maximum rated flow. Consult AMOT for further information if the application is sensitive to leakage rates or if high pressure differences are likely to occur.

3-Way Temperature Control Valve - Model G, Version G

Overview of Electric Actuation

Electric Actuator Specification Table									
	EC		EA		EB		EH		
Actuator									
Key Features & Benefits	<ul style="list-style-type: none"> Lightweight & economical valve actuator Manual override fitted as standard - valve can be operated in event of power failure EC050 with tool. EC100/EC300 with handwheel Optional Positioner available on all sizes 		<ul style="list-style-type: none"> Self-locking with minimal backlash in the transmission - prevents valve movement due to flow Auxiliary limit switches for user connection Manual override fitted as standard - valve can be operated in event of power failure Two torque switches - provide protection in event of actuator overloading 		<ul style="list-style-type: none"> High vibration resistance Self-locking with minimal backlash in transmission - prevents valve movement due to flow Auxiliary limit switches for user connection Manual override fitted as standard - valve can be operated in event of power failure Two torque switches - provide protection in event of actuator overloading Improved Duty Cycle 		<ul style="list-style-type: none"> High vibration and shock resistance Increased operating temperature range Hazardous location options available Manual override fitted to non-hazardous area version - valve can be operated in event of power failure Software is configurable for varying applications CAN bus communication Improved Duty Cycle 		
Power	115V ± 10% 230V ± 10%	50/60Hz Single Phase	115V ± 10% 230V ± 10%	50/60Hz Single Phase	115V ± 10% 230V ± 10%	50/60Hz Single Phase	24 VDC		
	24VAC/DC ± 10%								
Size Compatibility	EC050: 0.5GGH-06GGS EC0100: 06GGH-10GGS		EA100: 0.5GGH-10GGS		EB100: 0.5GGH-10GGS		EH125: 0.5-10GGS		
Duty Cycle @ 20°C	50%		65%		100%		100%		
Duty Cycle @ Max. Temp.	230V: 35% 24V: 100%		27%		115V: 45% 230V: 48%		100%		
Stroke Time	EC050: Fixed @ 15s EC0100: Fixed @ 19s		50Hz: Fixed @ 25s 60Hz: Fixed @ 21s		50Hz: Fixed @ 26s 60Hz: Fixed @ 22s		Adjustable ≥ 6s		
Max Current	EC050	115V : 0.54A 230V : 0.32A 24VAC/DC : 1.35A	220V : 0.88A 110V : 1.7A		220V : 0.88A 110V : 1.7A		5A		
	EC100	115V : 1.4A 230V : 0.69A 24VAC/DC : 4.8A 380VAC : 0.45A							
Limit Indication	Two open/close SPDT	250V AC, 5A	Two open/close SPDT	250V AC, 10A	Two open/close SPDT	250V AC, 10A	5V/10V Digital Outputs, 10mA		
Vibration Resistance Sinusoidal (*Lloyds Test 2)	N/A		5-100Hz 100-300Hz	4g* 1g* (90 mins)	5-100Hz 100-300Hz	4g* 1g* (90mins)	5-100Hz 100-300Hz	4g* 1g* (90 mins)	
Random	N/A		N/A		N/A		14.1 GRMS, 10-1000H 10 hours/axis		
Mechanical Shock	N/A		N/A		N/A		MIL-STD-810G 40g		
Motor Thermal Protection	Fitted as standard		Fitted as standard		Fitted as standard		Fitted as standard		
Ambient Temperature	Min.	Max.	Min.	Max.	Min.	Max.	Min.	Max.	
	-25°C	+70°C	-20°C	+70°C	-20°C	+70°C	-40°C	+125°C	
Weatherproof Enclosure	IP67	NEMA 4 & 6	IP67	NEMA 4 & 6	IP67	NEMA 4 & 6	IP67	IP69K	
Materials	Steel, Aluminum alloy, Aluminum bronze, Polycarbonate		Steel, Aluminum alloy, Aluminum bronze, Polycarbonate		Steel, Aluminum alloy, Aluminum bronze, Polycarbonate		Steel, Aluminum alloy, Aluminum bronze, Polycarbonate		
Angular Rotation	100° max.	1/4 Turn	100° max.	1/4 Turn	100° max.	1/4 Turn	90° Standard		
Position Sensor	Potentiometer		Potentiometer		Contactless hall effect		Contactless hall effect		
Cable Entry	EC050 : PG13.5 EC0100 : PG16		2x M25 x 1.5		2x M25 x 1.5		Control Type	Size	
							Analogue	2x M25 x 1.5	
							Digital	2x M20 x 1.5	
Mechanical Stop	EC050 : N/A EC0100 : Two adjustable screws		Two adjustable screws		Two adjustable screws		Internal, non-adjustable		
Manual Override	Fitted as standard		Fitted as standard		Fitted as standard		Fitted as standard		
External Coating	Dry powder polyester		Dry powder polyester		Dry powder polyester		Cast anodised aluminum		
Anti-Condensation Heater	7-10W		7-10W		7-10W		10W		

3-Way Temperature Control Valve - Model G, Version G

Overview of Pneumatic Actuation

Pneumatic Actuator Specification Table		
Actuator	F-Series	
		
Key Features & Benefits	<ul style="list-style-type: none"> • A rugged quarter turn, double piston, rack and pinion pneumatic actuator with spring return and valve positioner as standard. • Can be configured fail-safe • Low temperature version available 	
Supply Pressure	6 to 8 Bar	90 to 115 psi
Signal Pressure	0.21 to 1.03 Bar	3 to 15 psi
Pressure Connections	G1/4 or 1/4 NPT	
Ambient Temperature	Min.	Max.
	-20°C	+80°C
Manual Override	Optional	

3-Way Temperature Control Valve - Model G, Version G

Actuator Dimensions

EB Actuator

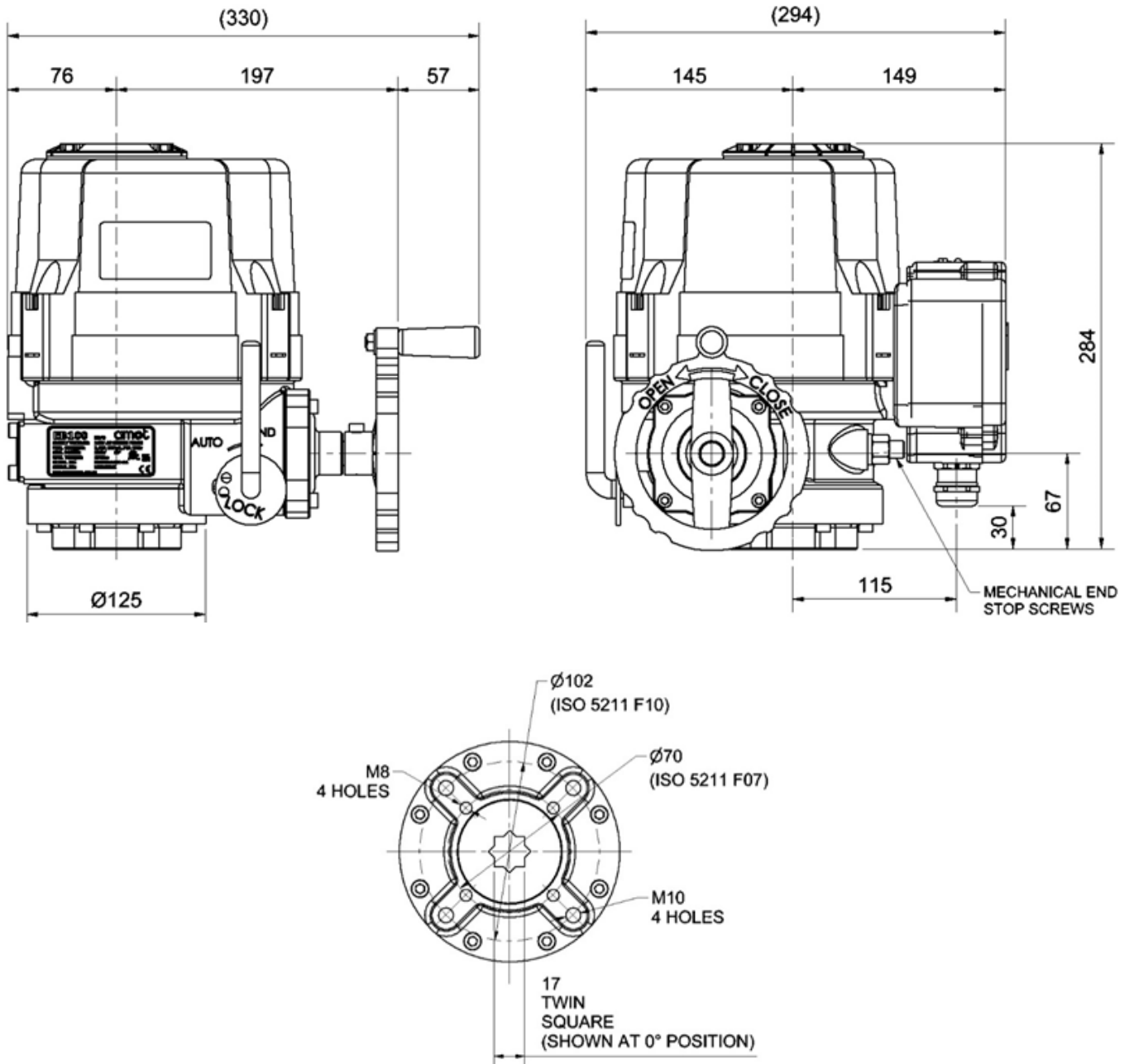

3-Way Temperature Control Valve - Model G, Version G

EA Actuator

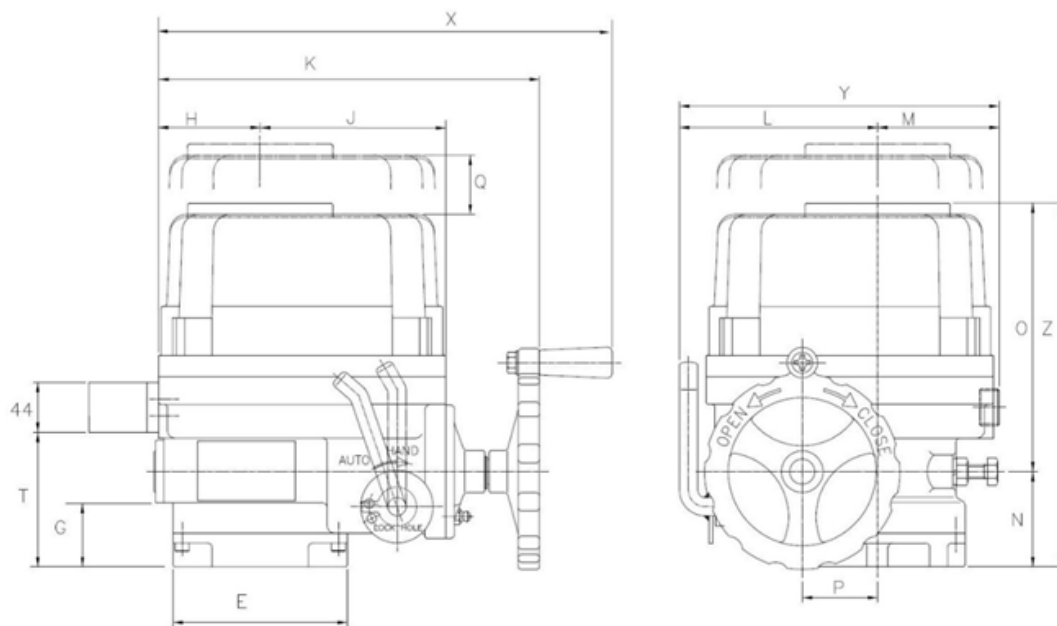
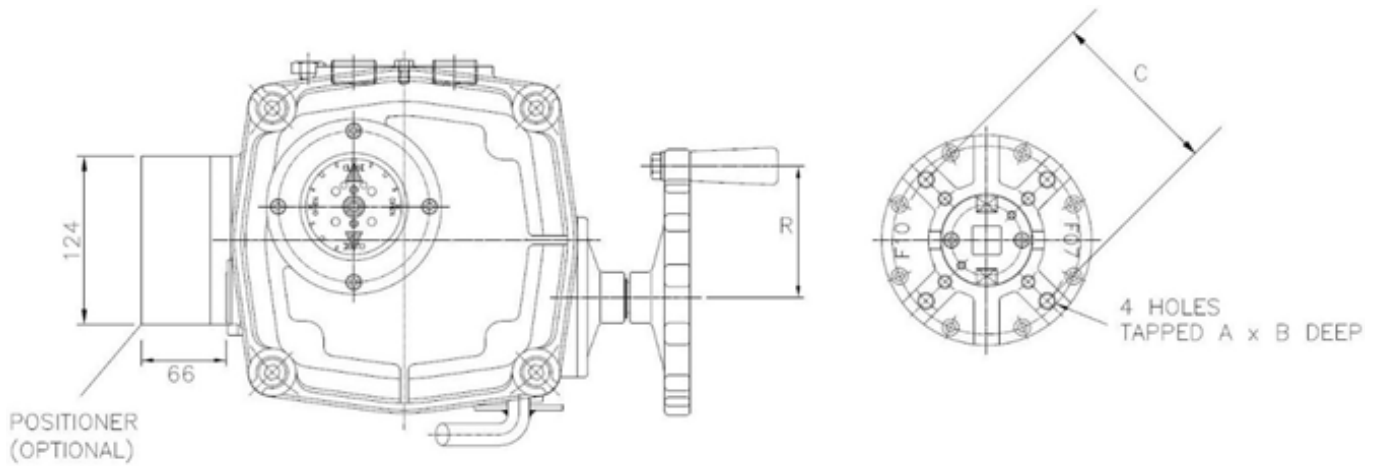

Units	Base	C	E	G	H	J	K	L	M	N	O	P	Q	R	T	X	Y	Z
mm	F10	102	125	42	73	133	273	142	87	68	192	54	160	78	86	338	229	268
Inches	F10	4.0	4.9	1.7	2.9	5.2	10.7	5.6	3.4	2.7	7.6	2.1	6.3	3.1	3.4	13.3	9.0	10.6

3-Way Temperature Control Valve - Model G, Version G

EC Actuator

EC050

Dimensions in mm [in]

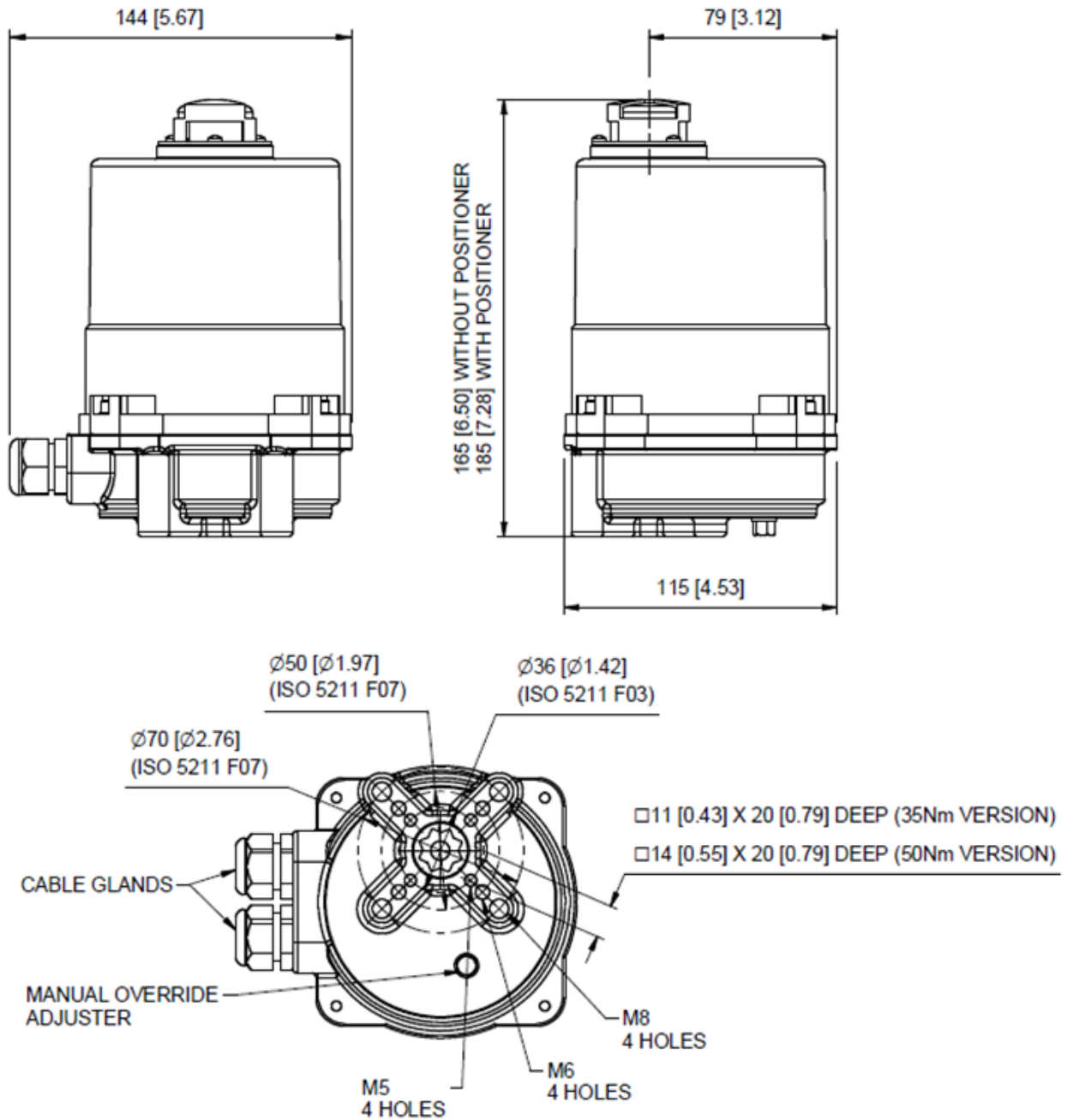

3-Way Temperature Control Valve - Model G, Version G

EC100

Dimensions in mm [in]

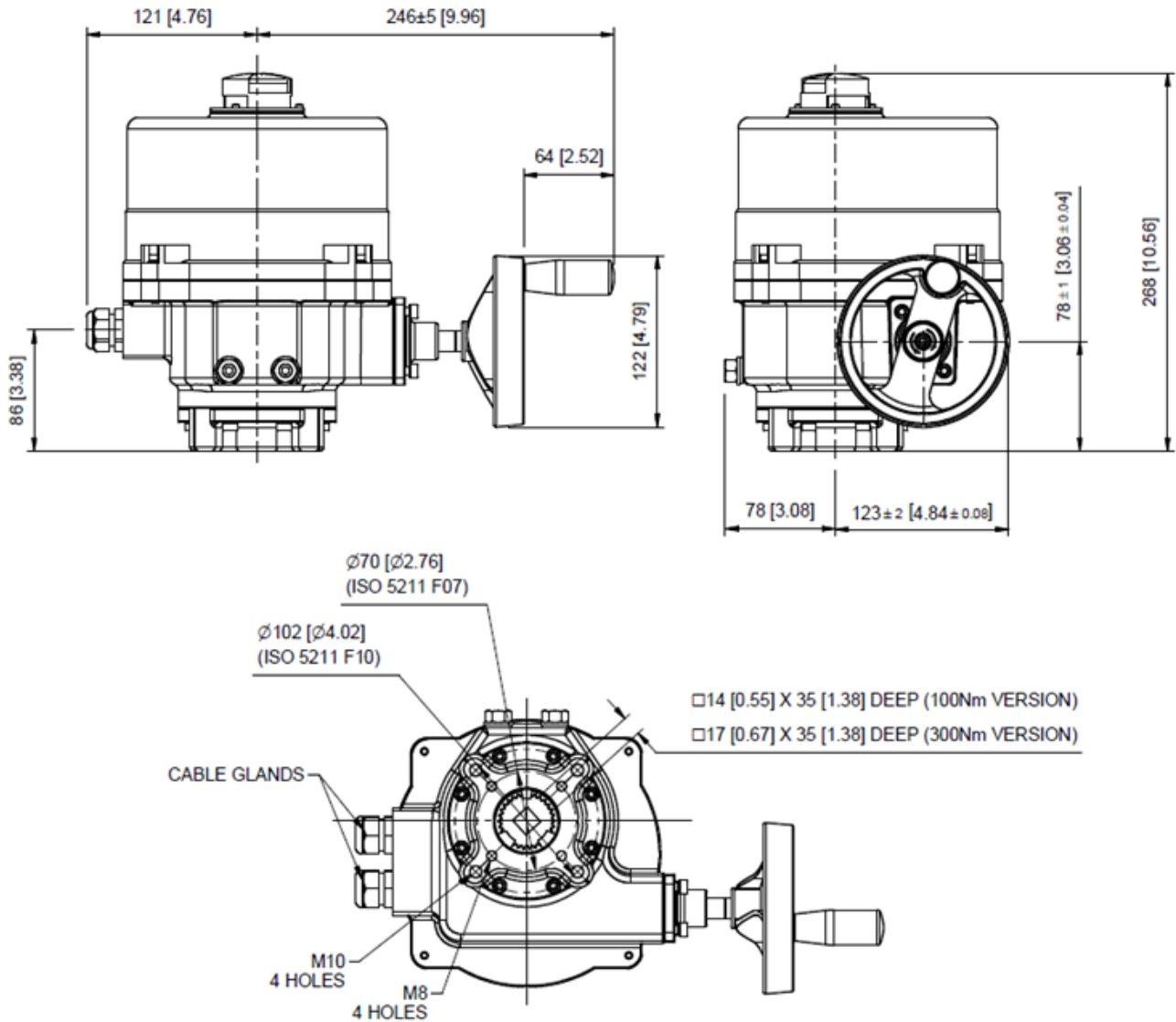

3-Way Temperature Control Valve - Model G, Version G

EH Actuator

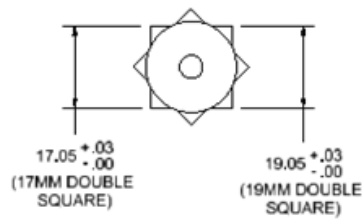
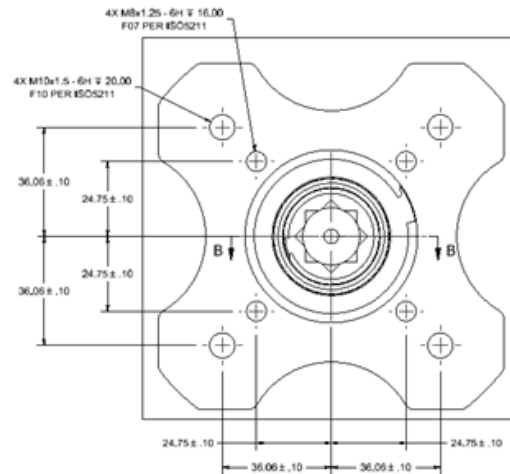
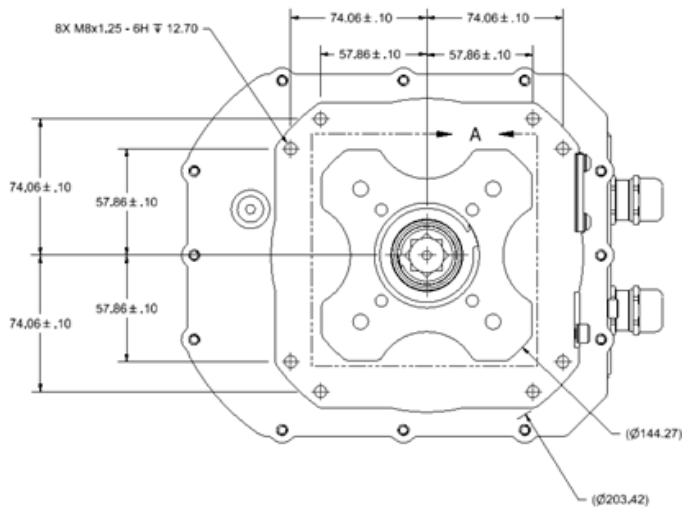
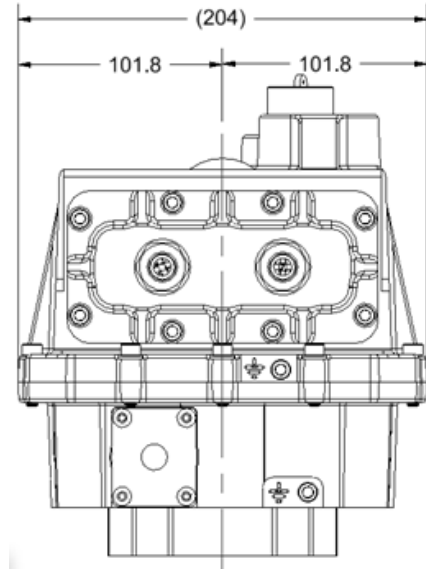
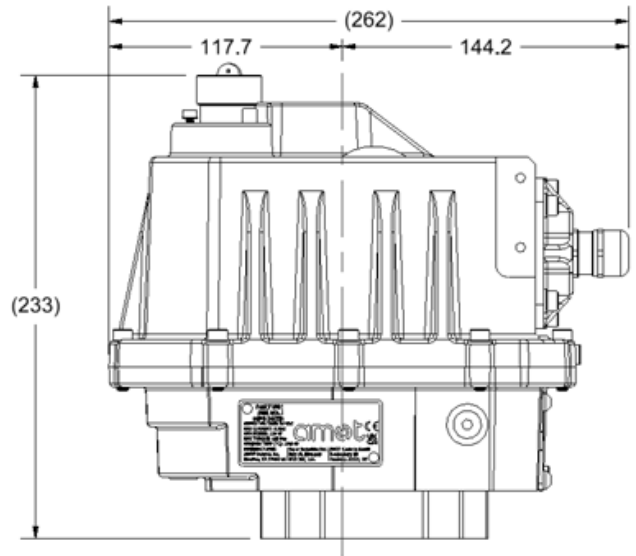

3-Way Temperature Control Valve - Model G, Version G

Pneumatic Actuator

Pneumatically Actuated

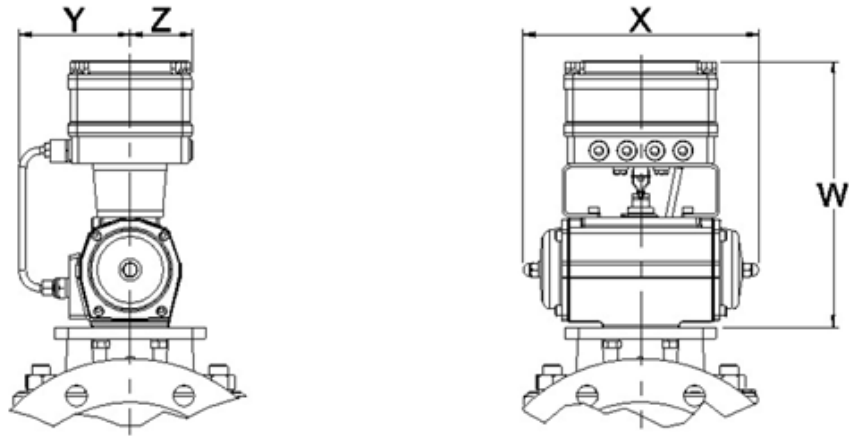

Pneumatically Actuated with Manual Override

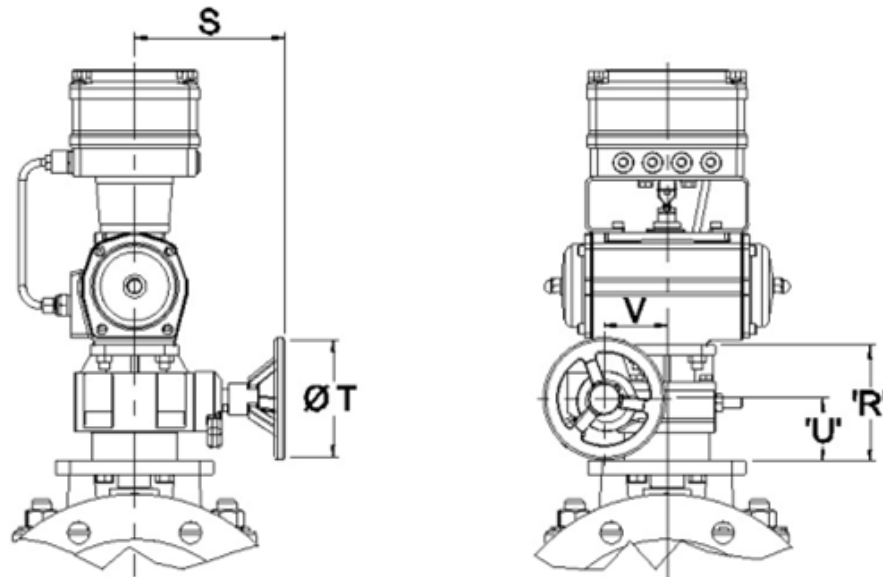

Dimensions in mm

Valve Type	Actuator								
	R	S	T	U	V	W	X	Y	Z
0.5GGH	103			61					
0.75GGH									
01GGH									
02GGH									
2.5GGS									
03GGS	168	100	60.5	49	245	192	95	53	
03GGH	92			49.5					
04GGS									
04GGH									
05GGS									
06GGS									
06GGH	137	230	200	86	74	288	362	115	53
08GGS	162			111					
08GGH	137			86					
08GGH	137			111					
10GGS	162			111					

Dimensions in Inches

Valve Type	Actuator								
	R	S	T	U	V	W	X	Y	Z
0.5GGH	4.06			2.40					
0.75GGH									
01GGH									
02GGH									
2.5GGS									
03GGS	6.61	3.94	2.38	1.93	9.65	7.56	3.74	2.09	
03GGH	3.62			1.95					
04GGS									
04GGH									
05GGS									
06GGS									
06GGH	5.39	9.06	7.87	3.39	2.91	11.34	14.25	4.53	2.09
08GGS	6.38			4.37					
08GGH	5.39			3.39					
08GGH	5.39			4.37					
10GGS	6.38			4.37					

3-Way Temperature Control Valve - Model G, Version G

How to Order

Example code	06	GG	S	D	B	S	32	E	B	B	C	A	-AA	Code Description						
Valve Size	0.5													Nominal Bore Size	1/2 inch (DN15)	High flow only				
	0.75													3/4 inch (DN20)	High flow only					
	01													1 inch (DN25)	High flow only					
	02													2 inch (DN50)	High flow only					
	2.5													2.5 inch (DN65)	Standard flow only					
	03													3 inch (DN80)						
	04													4 inch (DN100)						
	05													5 inch (DN125)	Standard flow only					
	06													6 inch (DN150)						
	08													8 inch (DN200)						
10													10 inch (DN250)	Standard flow only						
Valve Model	GG													Model Type	Model G Valve					
Valve Flow Type														Valve Flow Type	Standard Flow					
															High Flow					
															Standard Flow					
Valve Body/Seal Material														Body Material	Bronze	Seal Material	Viton (FKM)			
															Bronze	Nitrile (NBR)				
															Ductile Iron	Viton (FKM)				
															Ductile Iron	Nitrile (NBR)				
															Ductile Iron	Aflas (TFE/P)				
															Steel	Viton (FKM)				
															Steel	Nitrile (NBR)				
															Stainless Steel	Viton (FKM)				
															Stainless Steel	Nitrile (NBR)				
															Stainless Steel	EPDM				
														Nickel Aluminium Bronze	Viton (FKM)					
														Nickel Aluminium Bronze	Nitrile (NBR)					
Valve Flange Connection, Standard and Class														Flange Class	PN6	Flange Standard	EN 1092	Flange Facing	Raised	Comments
															1	EN 1092	Flat			
															B	EN 1092	Raised			
															2	EN 1092	Flat			
															C	EN 1092	Raised			
															3	EN 1092	Flat			
															J	ASME	Raised	Ductile Iron, Steel & St. Steel only		
															6	ASME	Flat			
															9	10K	Raised	Ductile Iron, Steel & St. Steel only		
															L	10K	Flat			
															7	5K	Raised	Ductile Iron, Steel & St. Steel only		
															M	5K	Flat			
															N	150	MIL-PRF-20042E	Flat	Bronze, Aluminium Bronze only	
	Rotor Type														Rotor Type	Standard Rotor		Comments		
														ANSI Class II (0.5%)		Ductile Iron only				
Valve Mode of Operation														Rotor Start Position			Rotor End Position			
														12	Port 1	Port 2	Port 3			
														23	Port 2	Port 3	Port 1			
														31	Port 3	Port 2	Port 1			
														21	Port 2	Port 1	Port 3			
														32	Port 3	Port 2	Port 1			
Valve Actuation Type														Actuator Type						
														E	EB Type Electric Actuator					
														F	EA Type Electric Actuator					
														G	EC Type Electric Actuator					
														H	EH Type Electric Actuator					
														L	Low Temp Pneumatic Actuator					
														P	F-series Pneumatic Actuator					
Actuator Power Supply														Actuator Supply Type				Comments		
														A	100 - 120 Vac 50/60Hz					
														B	200 - 240 Vac 50/60Hz					
														C	380 Vac, 3 Phase, 50/60Hz			EC Actuator only		
														E	24VDC			EC & EH Actuator only		
Actuator Control Input Signal														Input Signal				Type	Comments	
														A	Start	End	Direction	Relays, Switched Live Supply	Electric Actuators	
																N/A				
														B	4mA	20mA	(Direct Acting)			
														C	20mA	4mA	(Reverse Acting)			
														K	0V	10V	(Direct Acting)	EC & EH Actuator only		
														L	10V	0V	(Reverse Acting)	EC & EH Actuator only		
														M	0	1000	(Direct Acting)	CAN bus J1939	EH Actuator only	
Actuator Feedback Signal														Feedback Signal				Type	Comments	
														N	0%	100%	(Direct Acting)	Pulse-Width Modulation	EH Actuator only	
														1	3psi	15psi	(Direct Acting)		Pneumatic Actuators	
														2	15psi	3psi	(Reverse Acting)		Pneumatic Actuators	
														A		None			Electric Actuators	
														C	4mA	20mA	(Direct Acting)		Electric Actuators	
														E	20mA	4mA	(Reverse Acting)		Electric Actuators	
														K	0V	10V	(Direct Acting)		EC & EH Actuator only	
Other Options														Other Options				Comments		
														A	None			Electric Actuators		
														O	None			Pneumatic Actuators		
Customer Special Options														Options						
														-AA	Standard product					
														-***	Customer special code assigned					

3-Way Temperature Control Valve - Model G, Version G

Accessories

8071D/8072E and Solid State Relays 47581L001/47581L002



**PID Controller
8072E**



**Solid State
Relay**



**PID Controller
8071D**

Key features and benefits

- Fully programmable PID-based control - allows easy system configuration
- Universal inputs; RTD's, thermocouple, or standard 4-20mA signal gives maximum system design flexibility
- Can be operated in manual mode - easy maintenance and set up

For further information and how to order these products see
[Datasheet_8071/2E_47581_Valve Controller_SSR](#)

3-Wire PT100 Temperature Sensor - 8060



**Temperature Sensor
8060**

Key features and benefits

- 3 wire RTDs - accurate temperature measurement
- Excellent long term stability
- Good linearity
- Can use standard 3-core cable

For further information and how to order this product see
[Datasheet_8060A_Temp_Sensor](#)

3-Way Temperature Control Valve - Model G, Version G

Accessories

Solid State Relay Module - 8073C



Relay Module
8073C

Key features and benefits

- IP67 enclosure
- Alternative to using two individual SSRs type 47581L001/47581L002
- Good linearity
- Can use standard 3-core cable

The 8073C relay module incorporates two solid state relays with terminations in an IP67 enclosure. The 8073C is designed to be used with the 8071D controller logic outputs to drive voltages for the electrically actuated G valve. Features include: zero-crossing switching, relay and logic level inputs and IP67 enclosure.

Typical Applications

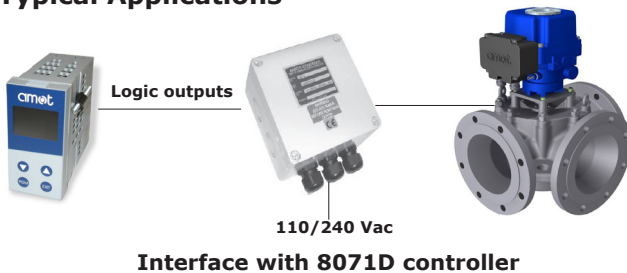

Interface with 8071D controller

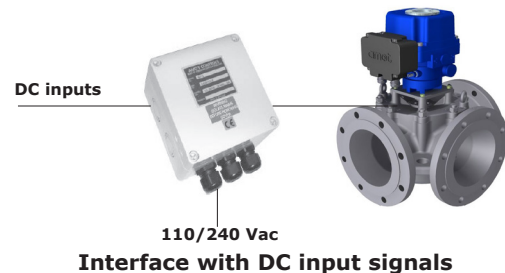

Interface with DC input signals

For further information and how to order this product see [Datasheet_8073C_SSR.pdf](#)

Electro-Pneumatic Converter - 8064A



Electro-Pneumatic
Converter - 8064A
(where available)

Typical Application

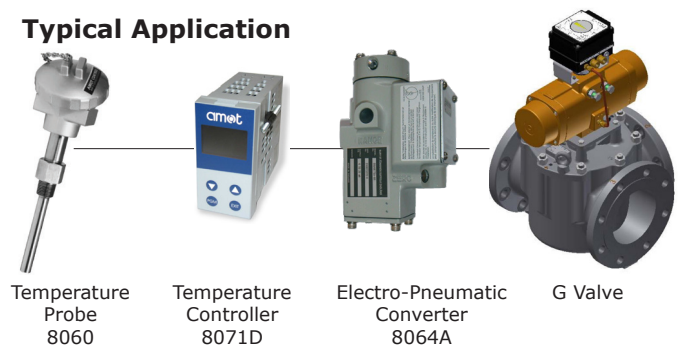

Key features and benefits

- High vibration resistance - Lloyds 4G
- Suitable for longer pipe runs
- Fully adjustable for optimized system operation
- ATEX hazardous area certification

For further information and how to order this product see [Datasheet_8064A_8064C_electro/pneumatic_converter](#)

3-Way Temperature Control Valve - Model G, Version G

Accessories

Electro-Pneumatic Converter - 8064C

Typical Application



Electro-Pneumatic Converter - 8064C

Key features and benefits

- Accepts high supply pressure - avoids use of additional regulator
- Factory set for ease of installation
- Low cost alternative to 8064A
- ATEX hazardous area certification

Electro-pneumatic system



Temperature probe 8060



Temperature controller 8071D



Electro-pneumatic converter 8064C

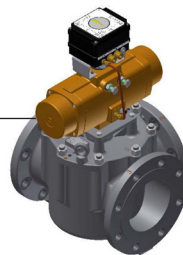

G valve

For further information and how to order this product see [Datasheet_8064A_8064C_electro/pneumatic_converter](#)

Pneumatic Indicator Controller - SG80



Pneumatic Indicator Controller SG80

Key features and benefits

- Complete stand alone controller, no other control components required - reduced system cost
- Easily removable components - low maintenance
- Good dynamic response - gives optimum engine performance
- Compatible with every type of pneumatic valve - flexible

Typical Application



SG80 Temperature Controller and Sensor

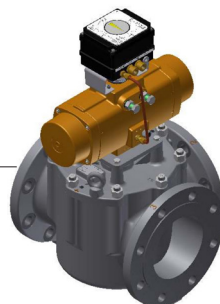

G Valve

For further information and how to order this product see [Datasheet_SG80_Pneu_Ind_Controller.pdf](#)

Americas

AMOT USA
8824 Fallbrook Dr
Houston
TX 77064
USA

Tel: +1 (281) 940 1800
Fax +1 (713) 559 9419
Email customer.service@amot.com

Asia Pacific

AMOT Shanghai
Bd. 7A, No 568
Longpan Rd, Malu Jiading
Shanghai 201801
China

Tel +86 (0) 21 5910 4052
Fax +86 (0) 21 5237 8560
Email shanghai@amot.com

Europe and Africa

AMOT
Western Way
Bury St Edmunds
Suffolk, IP33 3SZ
United Kingdom

Tel +44 (0) 1284 762222
Fax +44 (0) 1284 760256
Email info@amot.com

AMOT Controls GmbH
Rondenbarg 25
22525 Hamburg
Germany

Tel +49 (0) 40 8537 1298
Fax +49 (0) 40 8537 1331
Email germany@amot.com



WARNING

This product can expose you to chemicals including Lead, which is known to the state of California to cause cancer and birth defects or other reproductive harm. For more information go to www.P65Warnings.ca.gov.