

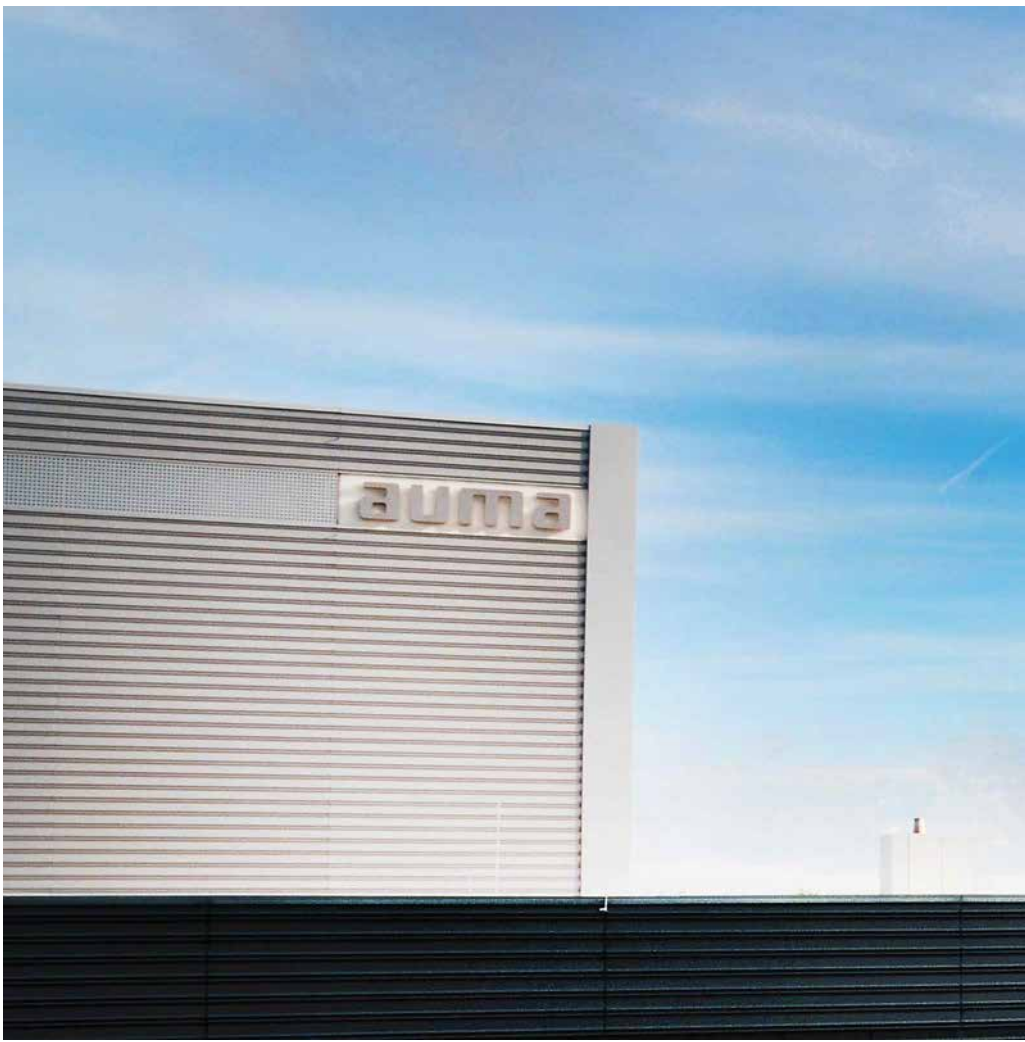

ELECTRIC ACTUATORS

for hydraulic steel structures & hydropower





ABOUT THIS BROCHURE

This brochure intends to describe functions and possible applications for electric actuators, actuator controls and gearboxes in civil engineering constructions for water applications and in hydropower. The document provides an introduction into the topic, an overview on products and established explanations regarding design and function of electric AUMA actuators.

On the rear pages of this brochure, you will find a chapter with detailed technical data for swift product selection. For device selection, further information can be obtained from specific data sheets. It will be our pleasure to assist you and provide any further details that might be needed.

The latest information on AUMA products can be found on the Internet at www.auma.com. All documents, including dimensional drawings, wiring diagrams, technical and electrical data sheets, as well as inspection certificates are available on the Internet in digital form.

Who is AUMA?	
About this brochure	2
AUMA - the specialist for electric actuators	4
Electrical actuators for hydraulic steel structures and hydropower	
Benefits of electric actuators	6
Applications for hydraulic steel structures and hydropower	8
Weirs, dams and locks	10
Fish ladders	14
Trash racks	15
Shut-off valves for turbines	18
Small hydroelectric power installations	19
Modular Range	
SA multi-turn actuators and SQ part-turn actuators	22
Automation solutions for all requirements	24
Service conditions	26
Underwater use	29
Basic actuator functions	30
Variable speed actuators	32
Adapting to the installation on site	33
Safety	
Protection for the valve, protection for the actuator	36
Protection against unauthorised use	37
Functional safety	38
Communication	
Integration into the DCS - control concepts	40
Communication - tailor-made interfaces	42
Communication - fieldbus	44
Operation and clarity	
AM and AC actuator controls	46
Clearly structured operation	48
Reliability, service life, maintenance - with test engineering features	50
AUMA CDT for AC controls - easy commissioning	52
AUMA CDT for AC controls - diagnostic dialogue	54
Design	
Uniform design for SA and SQ	56
Electromechanical control unit	62
Electronic control unit	63
Technical data	
SA multi-turn actuators	64
SAV multi-turn actuators	65
SA/GK multi-turn actuators	66
SA/GHT multi-turn actuators	67
SA/GS part-turn actuators	68
SA multi-turn actuators – Details	69
AM and AC actuator controls	73
Other type ranges	
Further AUMA products	78
Service	
Services	82
Certifications	84



Multi-turn actuators: Gate valves



Linear actuators: Globe valves



Part-turn actuators: Butterfly valves, ball and plug valves



Lever actuators: Dampers



AUMA - THE SPECIALIST FOR ELECTRIC ACTUATORS

Armaturen- Und MaschinenAntriebe - AUMA - is one of the leading manufacturers worldwide of electric actuators for automating shut-off and control valves. Since 1964, the founding year of the company, AUMA has focused on development, manufacture, sales and service of electric actuators.

AUMA actuators have proven themselves for more than 50 years in challenging applications of water supply and distribution as well as the hydraulic steel structures industry: in classic and regenerative power plants, in the chemical, petrochemical industry and all industrial systems worldwide. The brand AUMA is synonym to long-standing experience and knowledge.

Modular design

AUMA is entirely devoted to pursue their modular product concept. A comprehensive range of sub-assemblies allows for configuration of customer-specific actuators to suit the required application. The range of variants is possible due to clear interfaces between components whilst placing the highest demands on product quality as well as easy and straightforward maintenance of AUMA actuators.

Innovation on a day-to-day-business

As specialists for electric actuators, AUMA sets the market standard for innovation and sustainability. Within the framework of continual improvement, the in-house manufacturing process ensures prompt implementation of innovation at product or sub-assembly level. This applies to all areas relating to device function - mechanics, electrical engineering, electronics, and software.



Success is reflected by growth - worldwide

Since the foundation in 1964, AUMA has evolved into a company with 2,300 members of staff around the globe. AUMA proudly possesses a global sales and service network with more than 70 sales organisations and representative offices. Customers appreciate our expertise and competence in product consultation and our efficient after-sales service.

Selecting AUMA:

- > provides automation of shut-off and control valves of any type and size in compliance with submitted specifications
- > assures safety for design and implementation for plant engineering on the basis of certified interfaces
- > guarantees the operator global service on site including commissioning, comprehensive support, and product training.

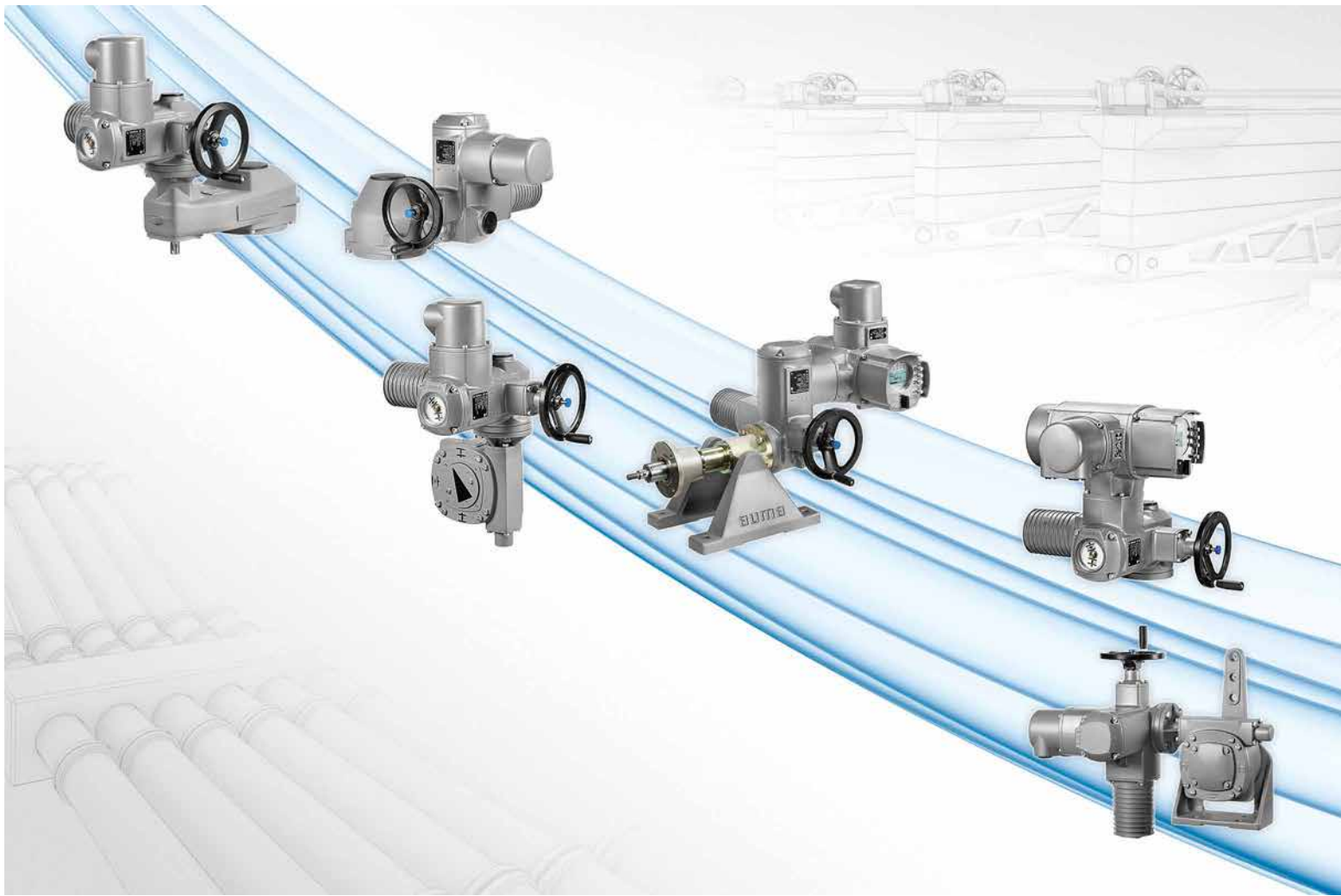

BENEFITS OF ELECTRIC ACTUATORS

AUMA supplies electric actuators solutions for automating shut-off and controls valves such as gate valves, butterfly valves, sluce gates, weirs and sluices.

Easy installation, low operating and maintenance costs, as well as comprehensive functions of the integral actuators controls – these are only a small selection of the benefits of electric actuator technology as compelling automation solutions in hydraulic engineering installations.

EASY TO INSTALL

They just require power supply and a signal cable: Installation of electric actuators is straight forward. Once connected, they are immediately ready for operation. International electrical approvals are available for operation of the devices all around the globe. All components like torque and end position monitoring are integral to the actuator.

The mechanical interface at the output drive is standardised, just like the output mounting flange. Easy exchange thanks to the compatibility of connections is guaranteed even after decades.

EASY TO INTEGRATE

Integral controls offer all required functions for operation and for parameter setting directly at the actuator.

Parallel and fieldbus interfaces in controls allow integration of AUMA actuators into all conventional distributed control systems. Among others, communication is supported via Profibus DP, Modbus RTU, Foundation Fieldbus, HART, WirelessHART, Profinet and Modbus TCP/IP.

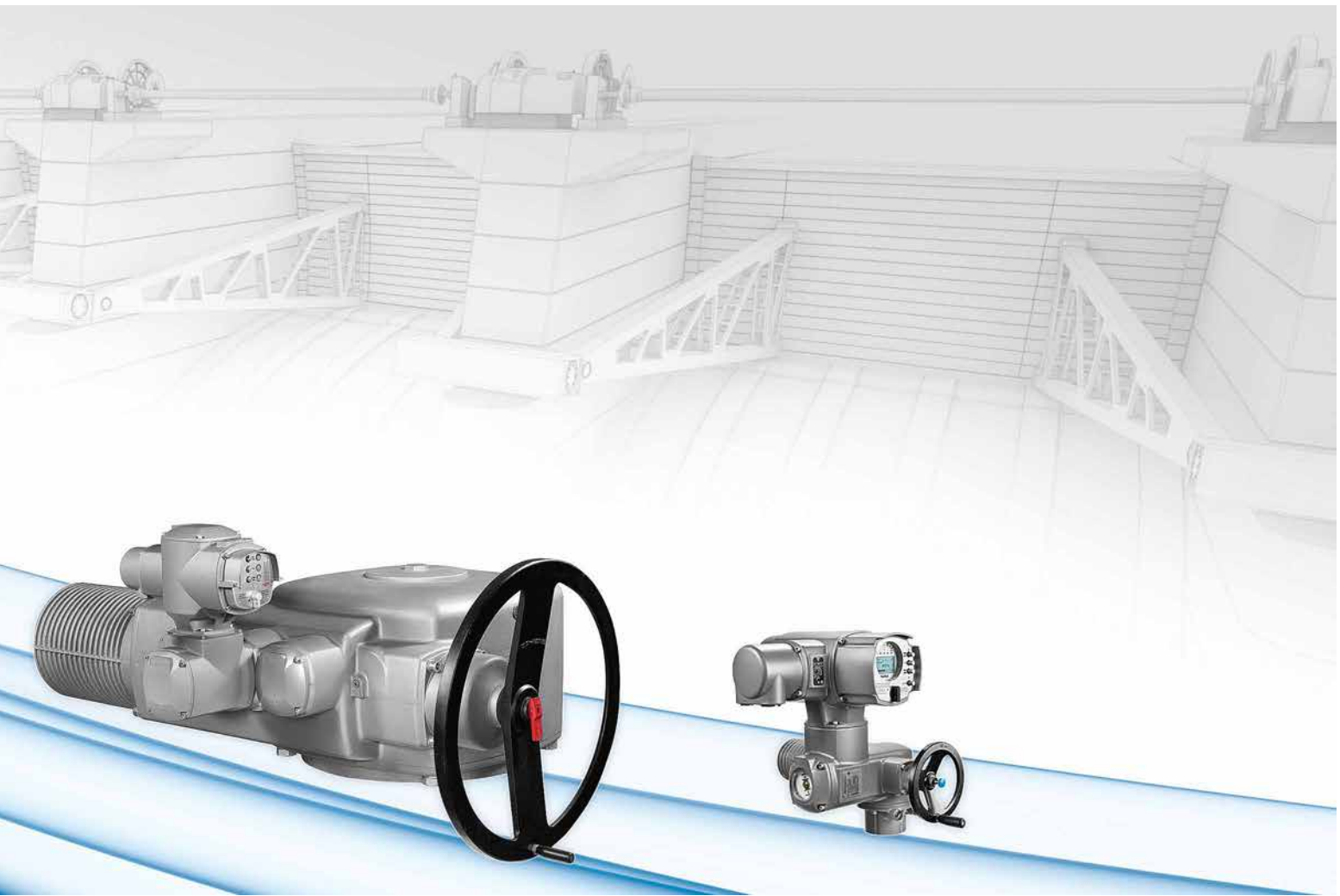

COST-EFFICIENT TO OPERATE

AUMA actuators consume little energy and are extremely low in maintenance requirements. This significantly contributes to their low Life-Cycle-Cost (LCC).

ROBUST AND RELIABLE

Thanks to their high-level IP68 enclosure protection and their excellent corrosion protection system, AUMA actuators withstand any weather impact. They excel in their reliable and safe operation under extreme climatic conditions.

Intelligent diagnostic functions of integral AC actuator controls allow permanent monitoring of lifetime factors and ensure for superior operational safety. A handwheel is available for manual emergency operation.

FREE OF OIL AND ENVIRONMENTALLY SOUND

Another asset: The actuators are free of oil and thus environment-friendly since there is no risk of contamination by leaking oil. Furthermore, they are particularly suited for drinking water applications.



APPLICATIONS FOR HYDRAULIC STEEL STRUCTURES AND HYDROPOWER

Reliability and long product life are the prime requirements for operating weirs and sluices in hydropower engineering installations. The major requirement in actuator technology is withstanding the harshest climatic conditions even after decades and warranting perfect function on demand.

AUMA offers individual electric actuator solutions for any application thanks to their comprehensive product portfolio of actuators, integral actuator controls and gearboxes.

CIVIL ENGINEERING CONSTRUCTIONS FOR WATER APPLICATIONS

For decades, AUMA actuators have proven their reliability for automation solutions in civil engineering constructions for water applications around the globe. The large number of reference projects in different sizes and construction type underpin this statement.

Civil engineering constructions for water applications set outstanding demands on actuators. Individual design is a prime requirement for nearly all applications.

Thanks to the continuous enhancement of AUMA's product portfolio, we are in a position to offer a suitable automation solution for all types of hydraulic steel structures, from the small channel penstock for water control to large weirs and segment gate weirs. The requirements of the German standard for hydraulic steel structures (DIN 19704) are met. For safety-related applications like for flood protection, they significantly contribute in saving lives and avoiding harm to people, environment and equipment.



HYDROPOWER

Hydroelectric power stations are in the spotlight for two trends: on the one hand the desire to harness the energy potential of running water as a clean source of energy, on the other hand the increasingly stringent severe environmental specifications. AUMA's efficient and clean electric actuator technology importantly contributes to economical and ecological utilization of hydro-power.

The wide product range is successfully deployed in all types of hydroelectric power stations: in run-of-the-river power plants (ROR) with low drops as well as in pump-storage hydroelectricity plants (PSH), in installations along small rivers with low flow rates as well as in large embankment dams.

Actuators prove their multiple benefits by their deployment in all parts of hydroelectric power stations, from the water level regulation at the power plant inlet, to the fish ladders, from automating trash racks to sophisticated and precise turbine control.

AUMA: YOUR COMPETENT PARTNER

We at AUMA are convinced by the trend-setting potential of the electro-mechanical actuation technology. We are extremely committed to find innovative solutions for all new applications in close partnership with research institutes, manufacturers, plant consultants and plant operators.

WORLDWIDE SALES AND SERVICE

We are your expert partner through our worldwide sales and service network in more than 70 countries. Our experts excel by their competence in planning and specifying actuator technology within the field of civil engineering constructions for water applications and hydroelectric power stations. AUMA service engineers are available all around the world to support you with installation, operation and maintenance of our products.

Please do not hesitate to contact us. It will be our pleasure to develop the suitable solution for your applications.

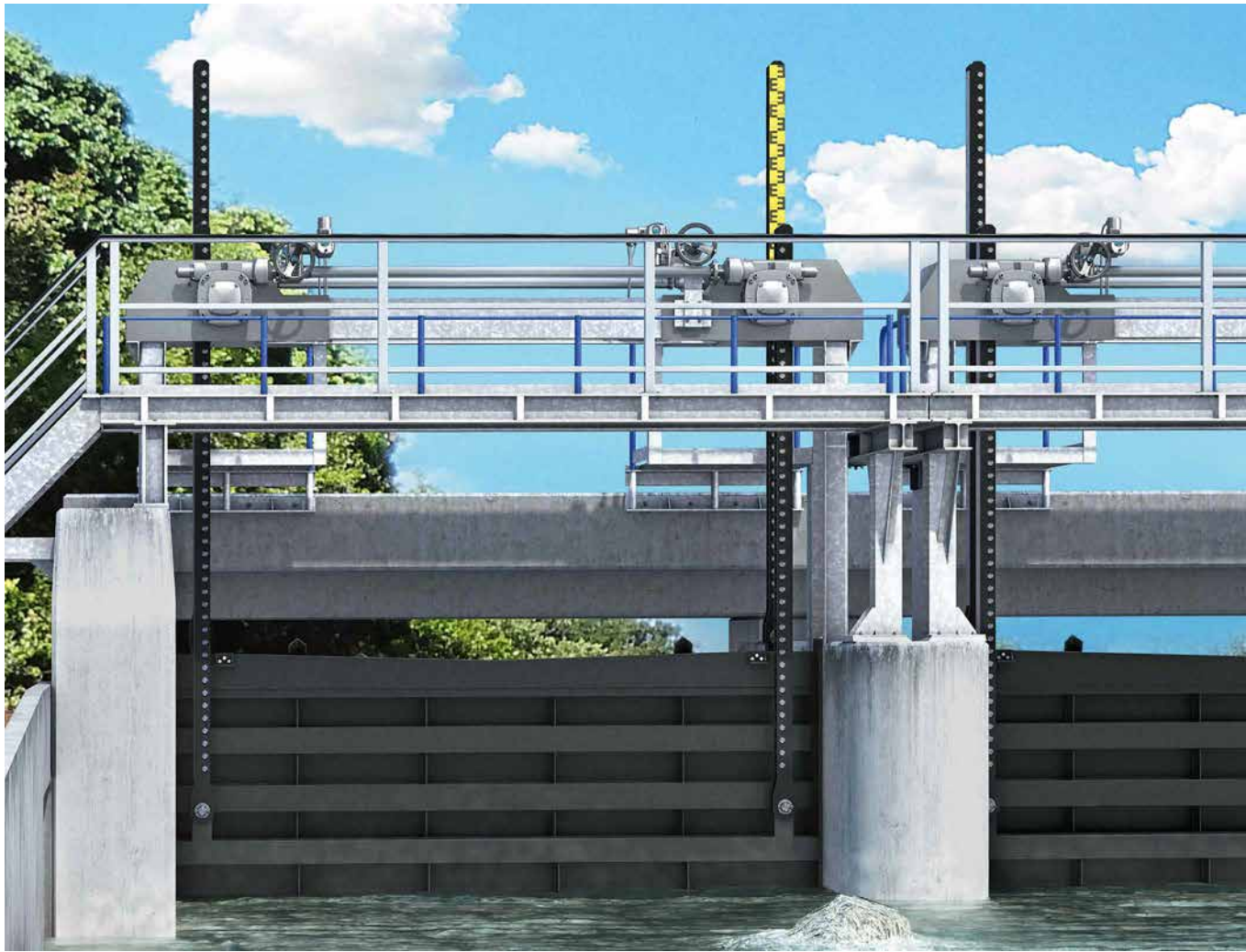

WEIRS, DAMS AND LOCKS

Weirs are installed for water level control of different water bodies and to ensure navigability of rivers and channels. Demands on reliability are, therefore, extremely high.

Actual level control is executed by positioning the weir penstocks. As a general rule, electric actuators are used for their automation. Large strokes, long or fast operating times and virtually constant and elevated torque requirements across the complete travel are typical actuators requirements in this market segment.

Dams and weirs nearly always require specific solutions due to the many variations of this type of application. Marginal conditions are the key factors for sizing the actuators used. Crucial issues are whether reserves have to be allowed for environmental changes in case of ice load or wind load and how drift material deposit at the weir influence load over time?

The situation is similar for locks since they have to ensure permanent availability of inland waterways. The frequent operation is very challenging, in particular, if locks are used throughout the year, in summer and in winter.

The multitude of combinations between AUMA actuators and gearboxes cater for tailor-made solutions for all these requirements.

SPECIFICATION ACCORDING TO DIN 19704

It is not unusual in civil engineering constructions for water applications that component design has to comply with DIN 19704, the standard for hydraulic steel structures. AUMA's actuator solutions fulfil these requirements. The requested lifetime can be ensured by monitoring just a few components.

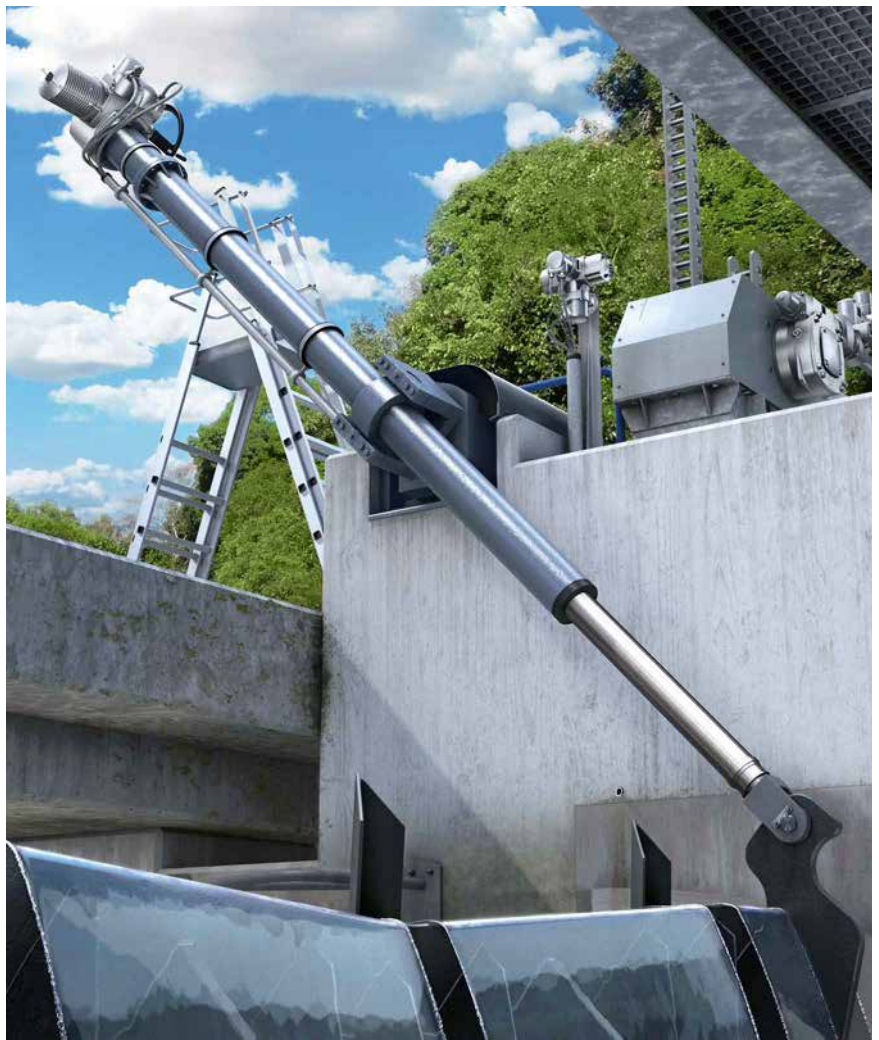
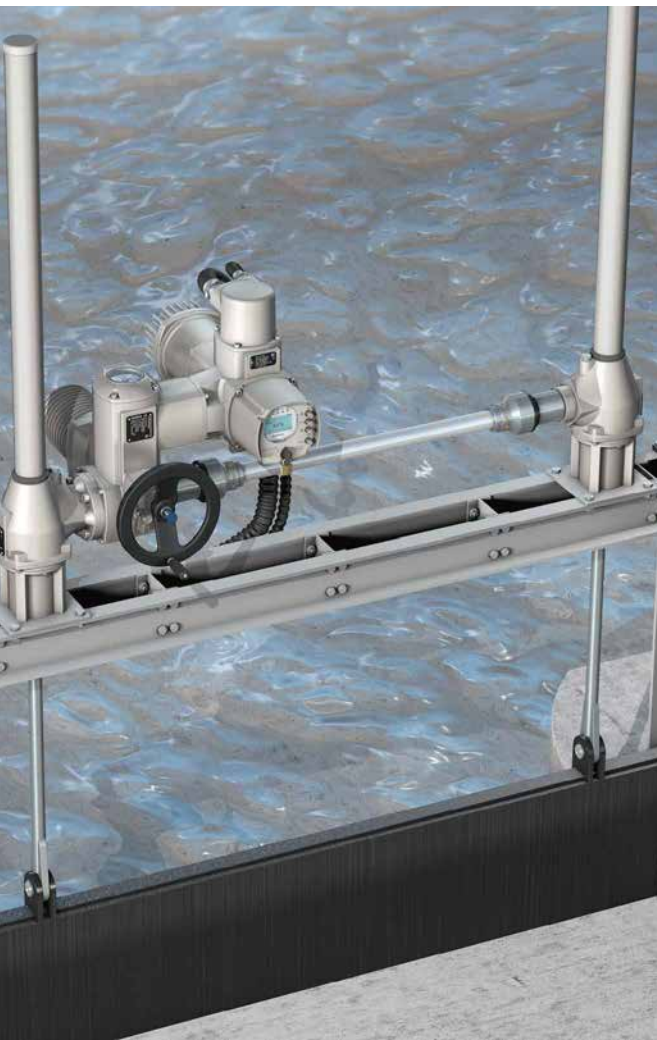

SIMPLE FAIL SAFE SOLUTIONS

It is fairly easy to perform safety-related functions by means of electric actuators. Non self-locking actuator gearbox combinations can be installed: In case of power failure or an emergency signal, they automatically either close a weir thanks to gravity or open the gate in the case of fishbelly flap gates.

SMOOTH OPERATION

Using innovative variable speed actuators, soft start of lifting or lowering movements for weirs is now possible. The operating speed is also reduced prior to reaching the end position. This type of control ensures sustainable protection of mechanical components thus extending their expected lifetime.

SYNCHRONOUS OPERATION

Large sluice weirs are often driven from two sides. The selected actuator solution must secure that both sides move simultaneously during opening and closing thus avoiding gate panel jamming. AUMA offers various solutions for synchronous operation.



WEIRS, DAMS AND LOCKS

Depending on the specific requirements like hydrostatic pressure, weather conditions, height of strokes or weight of the gate panels, individual actuator systems are to be deployed.

AUMA supplies electric actuator solutions for all conventional systems: No matter if dealing with stems, toothed rack, lantern gear or electrical lifting cylinders – thanks to the large variety in sizes and combinations with gearboxes, AUMA can offer the perfect solution. More exceptional actuator types like chain hoist or cable winches are easy to automate.

Stem

Actuator systems with rising or non-rising valve stems are widely used. The rotary movement of the actuators is converted into a lifting and lowering movement of the gate panel thanks to the stem.

Simple spindle gates (refer to picture on page 14) or double stem gate valves (centre figure pages 10/11) are often self-locking due to the friction of the spindle pitch. If required, these applications can be designed as non self-locking.

Lantern gear

A lantern gear is made of two lateral sheets. Between these sheets, cylindrical bolts are soldered in regular distance. The lantern gear is driven via a lantern gear wheel.

AUMA's actuator solution for lantern gear and double-stem gate valves (figure top and page 10 top left) comprise in general a combination of actuator and multi-turn gearbox. They are optimally adapted to the required number of revolutions and force. Lantern gears are perfectly suited to operate heavy loads like gate panels. Gravity-controlled fail safe applications are feasible for configurations without self-locking.



Sluice gate drives

The actuator uses sluice gate drives to transmit torque via a pinion to the toothed rack, connected to the sluice gate (right picture above). Bearing and pinion are often comprised in one housing.

This actuator type offers a simple solution for smaller sluice gates and infrequent use. AUMA supplies the suitable actuator depending on stroke and force requirement.

Electrical lifting cylinder

Electrical lifting cylinders (ELC) include a piston rod which is operated in linear movements up and down by an electric actuator (figure page 11 top right). Due to the enclosed design, the device is insensitive to ingress of dirt. They are particularly suited for frequent operation and heavy weights. Gravity-controlled fail safe applications are feasible for configurations without self-locking.

Electrical lifting cylinders are the preferred selection for mitre gates at locks and for fishbelly flap gates. The complete unit including actuator is suitable for underwater use.

Chain hoist

Actuator systems in weir systems like mills, segment gates, roller gates and butterfly valves or in locks like lift gates, lift-drop gates or drop gates are implemented by using special chains with high breaking strength.

Solutions with chain hoists are particularly suited for large stroke lengths. Whereas other actuator types would reach a height of many meters, the chain is simply threaded. This way, strokes of some 20 metres are perfectly feasible.

Cable winch

Cable winches are less popular in actuator technology. The gate panel is suspended by two cables which are reeled and unreel during lifting and lowering operations (picture top left).



FISH LADDERS

Fish ladders are used to ensure continuity of watercourses and to allow domestic fish to overcome hydraulic steel structures. Many research projects deal with the optimum type and setup of fish ladders. Different schemes are being deployed, from the classical fish ladder to the sophisticated fish lift.

To allow upriver fish migration from downstream towards fish ladders, the water from the fish ladder must discharge at a defined flow velocity into the river, the so-called attraction flow.

One of many common methods is to throttle flow velocity at the water mouth by means of weirs. Since the flow velocity depends on the river water level, the weir position must be controlled to achieve the desired flow behaviour. Whatever the application demands, AUMA actuators can take over the required control mission.

Integral PID controller

AUMA actuators are available with integral PID controller. The controller is integrated within the actuator housing with enclosure protection complying with IP68. A water level probe installed within the fish ladder can be directly connected to the actuator controls. Flow control is completely taken over by the integrated process controller in compliance with a predefined target setpoint. Further water-control components like an PLC are not required. The system can work autonomously. As an option, it is of course possible to define the target setpoint from the control room or to return a feedback signal to the DCS if required.



TRASH RACKS

Any waterway carries flotsam and bed load like branches, logs and stone at certain times. Modern cleaning rake screening system at the hydroelectric power station inlet reliably cater for collection and removal of such debris.

Electric actuators are integral part of new environmentally-sound solutions. AUMA has significantly participated in this development project. AUMA actuators are particularly suited for these applications thanks to the low Life-Cycle-Cost, the oil-free operation and their superior functional safety.

Drum rack screens

For the drum rack screen system (picture above), each drum is equipped with an AUMA actuator, guiding the drum in a constant and slow rotary movement. This movement deviates the complete flotsam from the screen bars to a drainage channel resulting in transporting the debris with the drag flow with a simultaneous cleaning effect.

Horizontal rack screens

Horizontal rack screens system are hardly visible, completely submersed in watercourses. Even the actuators are below the water surface. AUMA offers special actuators suited for continuous underwater use.

Automatic deblocking

Jammed branches or logs prevent smooth operation of horizontal rack screens but also opening or closing of sluice gates and weirs. If this is the case, the actuator torque rises until a torque fault is detected and the actuator is switched off.

In general, manual operation is required to remove the jammed object and to restart the actuator. However, AUMA actuators are equipped with a programmable automatic deblocking function initiating the actuator to operate several times backwards and forward to remove the jammed object and to eliminate blockage.

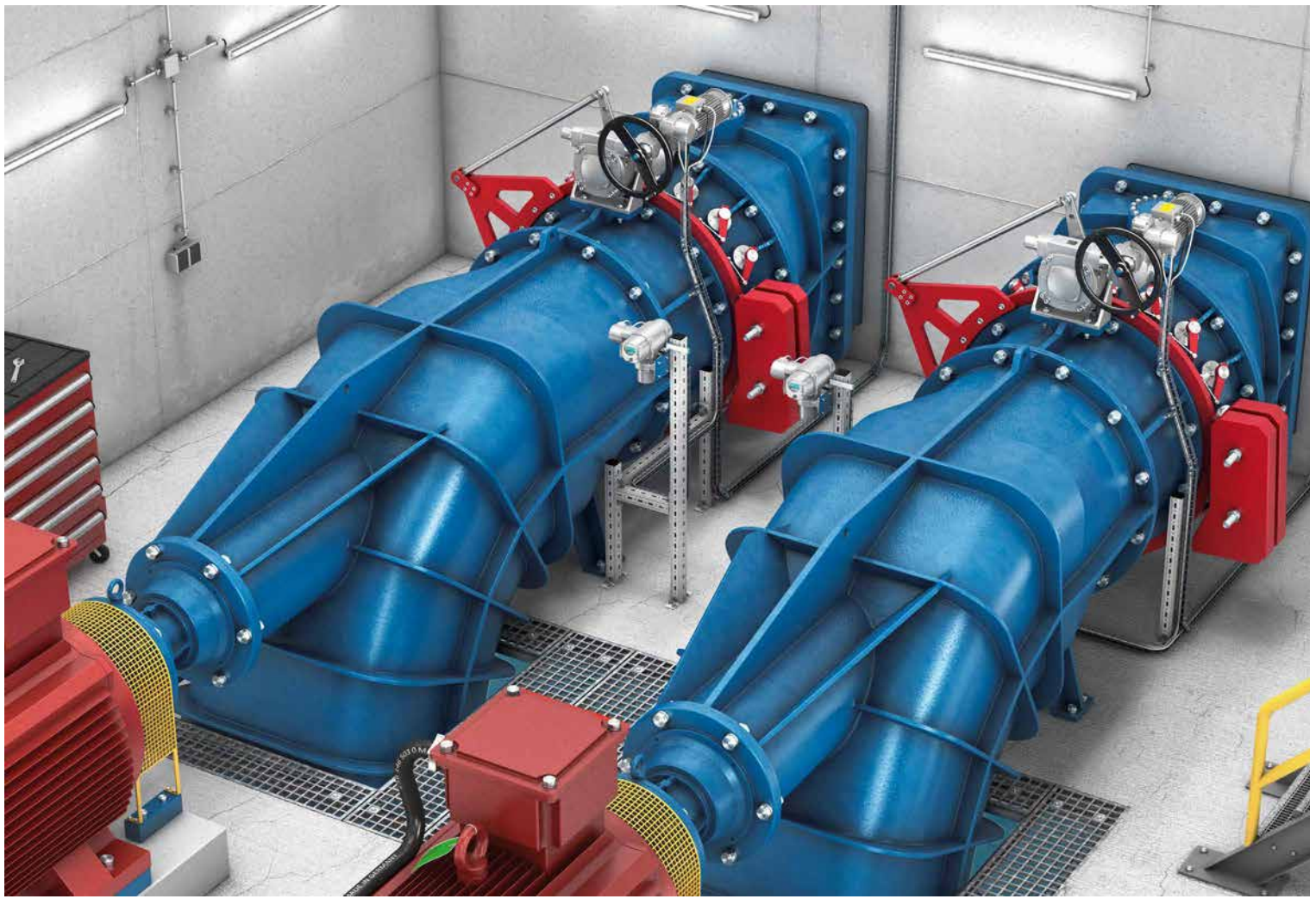

TURBINE CONTROL

The turbine is the core piece of hydroelectric power stations. Conditions like water drop height and flow rate are decisive for size and design of the selected turbine.

AUMA's comprehensive product portfolio allows solutions for conventional turbine control, including Kaplan, Francis and Pelton turbines. Various other designs can also be automated. Multi-turn, part-turn or linear movements of the control or shut-off valves can be carried out.

Typical control tasks include guide vane adjustment, stream deviation and spear head adjustment.

Example of Kaplan turbine

The illustration above shows the guide vane adjustment at a Kaplan turbine by means of a lever actuator – a combination between an AUMA multi-turn actuator and a part-turn gearbox with base and lever. The actuator allows precise turbine control. It is equipped with a brake motor, ensuring that the preset setpoint is respected.

For fast closing, voltage supply is disconnected at the actuator and the drop weight pulls the guide vanes via the positioning ring into the closed position.

Another solution is the use of AUMA variable speed multi-turn actuators: When approaching the setpoint, the actuator continuously reduces the operating speed. Consequently, the control accuracy is considerably increased. In case of an emergency, the actuator is able to close the valve quickly at the operating speed required for the application. For variable speed actuators, power supply for fast closing can conveniently be provided via a uninterruptible power supply (UPS).

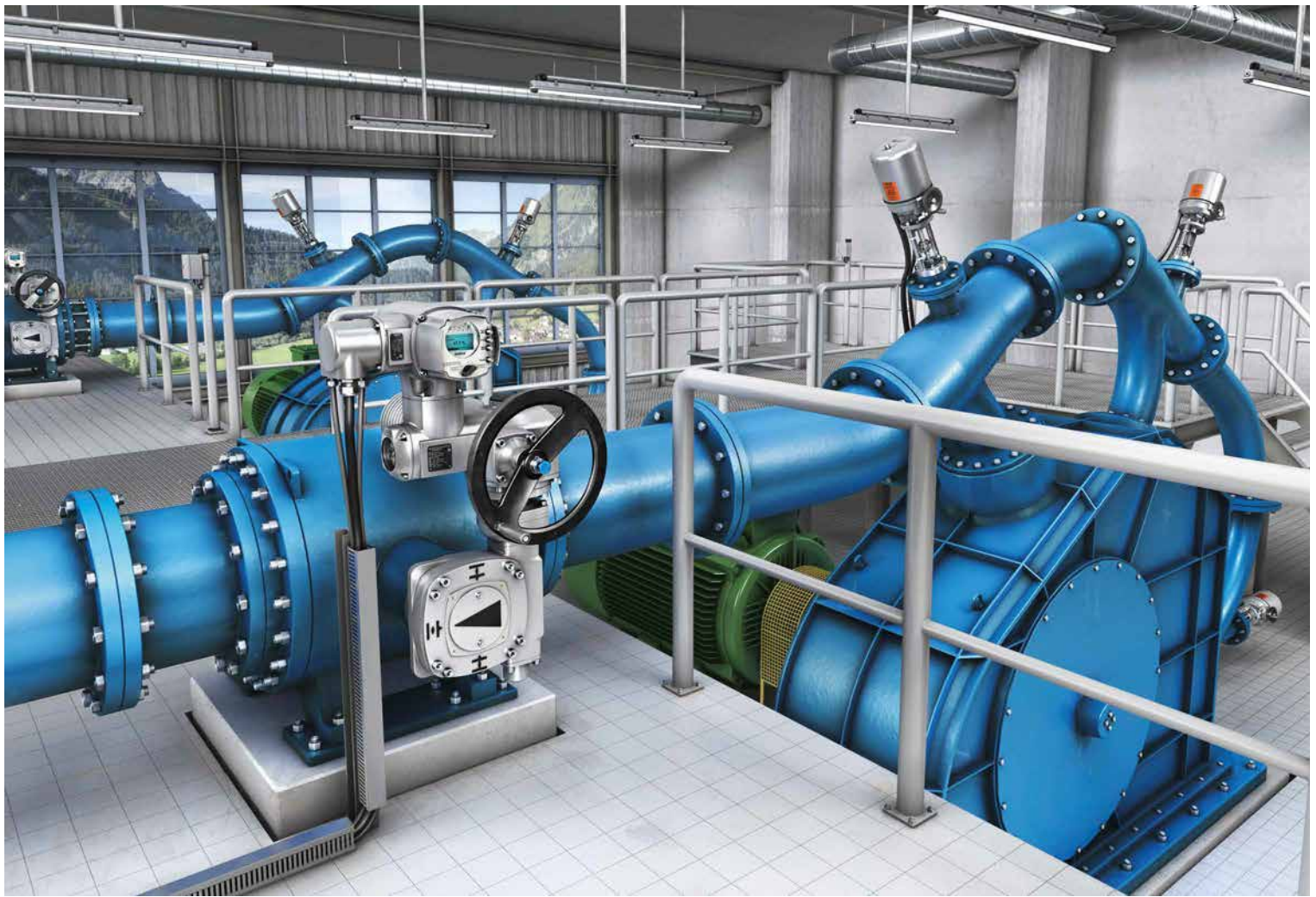

Example of Pelton turbine

AUMA even provides suitable solutions for spear head adjustment in Pelton turbines. Depending on the turbine size, various product combinations might be used.

AUMA's product portfolio includes compact linear actuators with excellent modulating characteristics for smaller turbines (illustrated above).

For larger turbines, we recommend using variable speed actuators mentioned before, combined with a suitable linear thrust unit.



SHUT-OFF VALVES FOR TURBINES

Shutting off water supply to turbines is of utmost importance for the operation of hydropower plants. Usually, an additional shut-off valve is installed upstream the turbine, meeting the most demanding requirements. In the event of an emergency, for example, if the generator is disconnected from the mains and no load is available, the shut-off device has to close reliably within a defined interval to avoid damage to both turbine and generator.

Depending on the amount of torque required, different actuator solutions may be deployed.

Lower torques can be provided by a multi-turn actuator combined with a part-turn gearbox (refer to illustration on page 17).

Variable speed actuators provide a significant advantage since the operating speed can be reduced prior to reaching end position CLOSED. This avoids the risk of pressure surges or even bursting of down pipes due to the high water pressure acting upon the pipes. When protected by a UPS, variable speed actuators have the advantage that due to low start-up currents, the UPS can be rather small and cost-efficient.

Highest torques

Combined with an electrical lifting cylinder, extremely high torque exceeding one million Newton metres can be generated electrically. These solutions are suitable for operating huge butterfly valves with diameters of several metres (figure above).

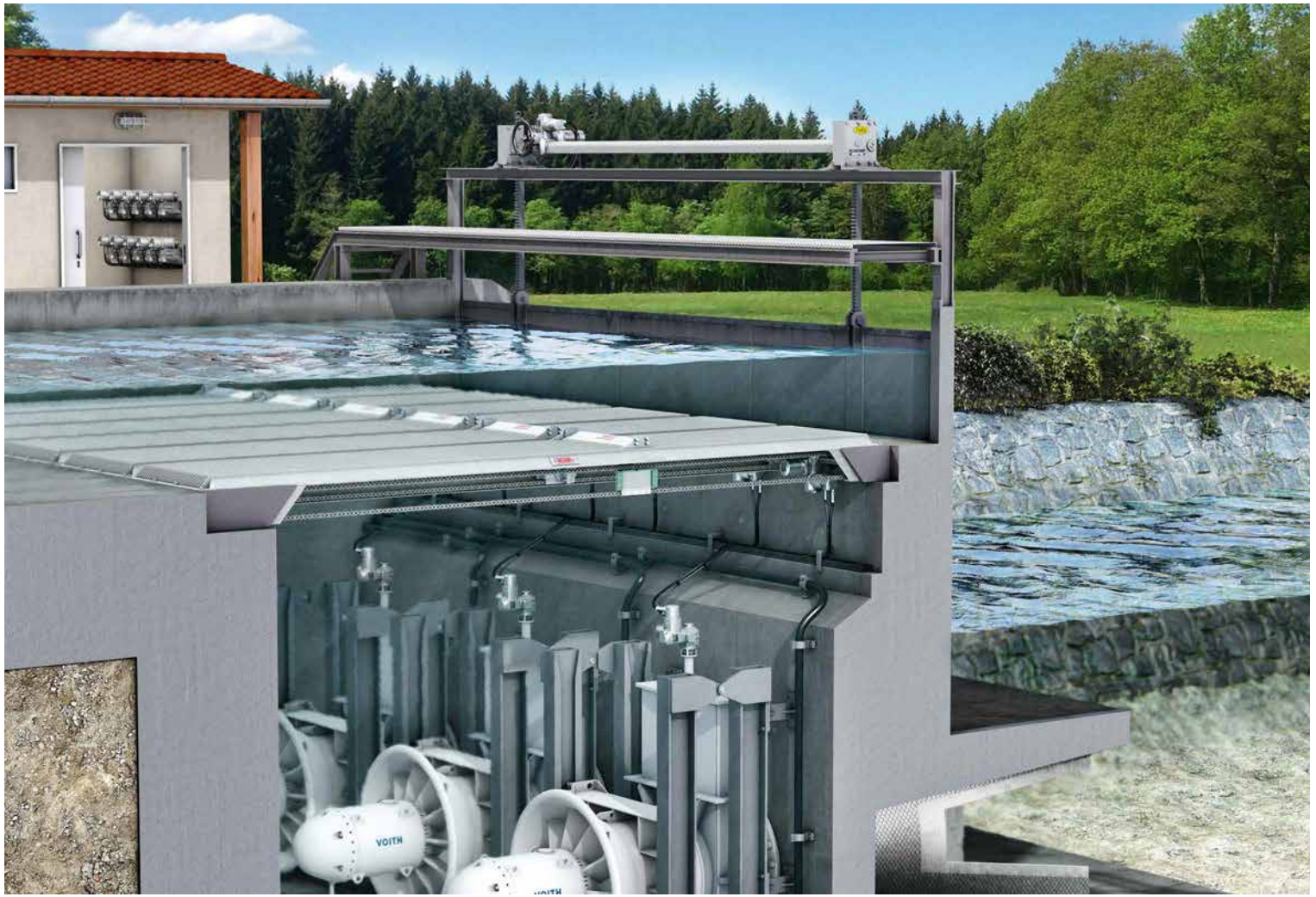

SMALL HYDROELECTRIC POWER INSTALLATIONS

Innovative solutions have been developed in particular for small hydroelectric power installations to use untapped energy potential from an economical and ecological point of view. They include innovative hydroelectric power schemes for watercourse with low fall of water.

The basic idea: Turbine and generator are installed in a pit below water level. Apart from the weir, hardly anything is visible from the outside; large conventional machine buildings are not required. These schemes are particularly suited for existing weirs or dams with low drops which can easily be retrofitted with power plants of this kind.

Underwater applications

AUMA actuators for continuous underwater use are the perfect electric actuation solution: The actuators are deployed at three points: At the horizontal rack screen, at the sluice gate as well as during underwater turbine start-up, synchronisation and cut-off.

MODULAR RANGE



SA multi-turn actuators and SQ part-turn actuators with AM and AC integral controls are robust and versatile.



SA MULTI-TURN ACTUATORS AND SQ PART-TURN ACTUATORS

Safe and efficient operation of hydropower plants is based on a high degree of automation for the various cut-off and control valves. This is the requirement for managing complex processes.

Electric actuators position the sluice gate or the weir in compliance with the operation commands issued by the DCS. When reaching the end position or the intermediate position, the actuator stops and signals the status to the control system.

Specific types of motion require specific actuator types. SA multi-turn actuators and SQ part-turn actuators are the core products of the AUMA product portfolio.

Impact of electric actuators

Electric actuators are equipped with an specifically developed electric motor/gearbox combination, providing the torque required for operating the moving elements of gates, butterfly valves, sluice gates, lock gates or globe valves. A standard handwheel allows manual operation. During positioning, the actuator records travel and torque data. Actuator controls process this data and are responsible for switching the actuator motor on and off. Typically, actuator controls are integrated within the actuator and are equipped with a local control unit apart from the electrical interface to the DCS.

This basic function of AUMA actuators is the same across all products.

SA multi-turn actuators and SQ part-turn actuators

Both type ranges are based on the same design principle. Commissioning and operation are virtually identical.

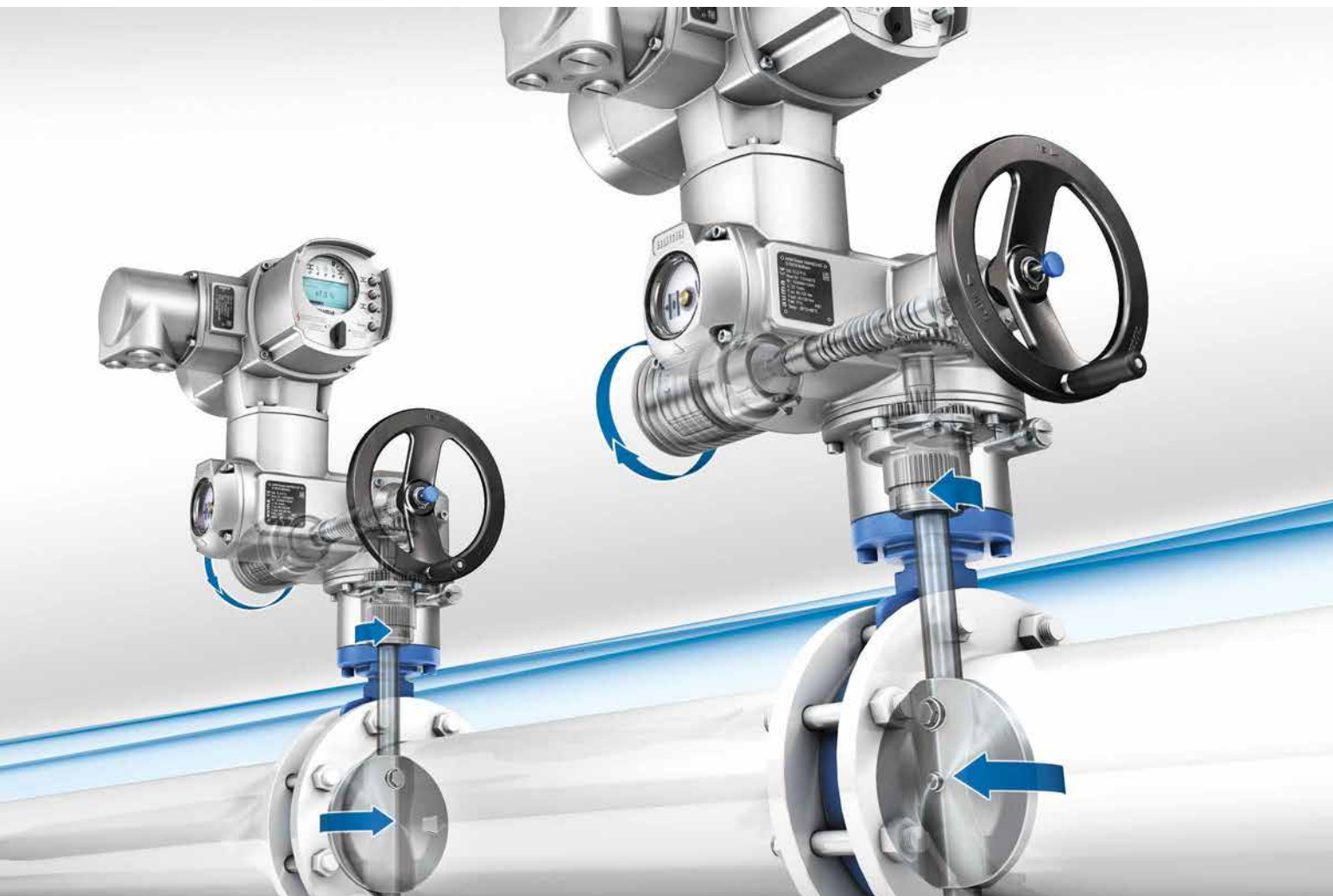

SA multi-turn actuators

In compliance with EN ISO 5210, a multi-turn actuator is capable of withstanding thrust applied to the valve and transmits torque to the valve for at least one revolution. In general, multi-turn actuators are required to perform more than one revolution. Consequently gate valves are often equipped with rising valve stems. They are operated on the basis of several revolutions performed by the multi-turn actuator. Therefore, the multi-turn actuator is equipped with a hollow shaft housing the gate valve stem for these applications.

SQ part-turn actuators

In compliance with EN ISO 5211, part-turn actuators transmit torque to the valve for a rotation of one revolution or less. They do not have to be capable of withstanding axial thrust.

SA multi-turn actuators with mounted gearbox

The application range is considerably increased by mounting AUMA gearboxes to SA multi-turn actuators.

- > A multi-turn actuator with higher output torque is obtained when combining with GK, GHT or GST multi-turn gearboxes. Apart from this, solutions for special valve types or installations can be implemented.
- > The combination with LE linear thrust unit acts as linear actuator.
- > The combination with GF lever gearbox acts as lever actuator.
- > In particular when requiring higher torques, we obtain a part-turn actuator when combining with GS gearbox.

AC 01.2 ACTUATOR CONTROLS

- > Microprocessor based with enhanced functions
- > Fieldbus communication
- > Display
- > Diagnostics
- > etc.



AM 01.1 ACTUATOR CONTROLS

- > Simple controls providing basic functions

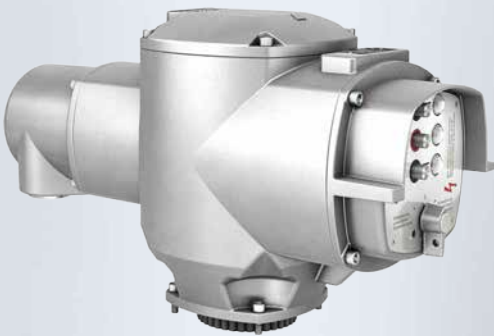



MULTI-TURN ACTUATORS SA 07.2 – SA 16.2 AND SA 25.1 – SA 48.1

- > Torques: 10 Nm – 32,000 Nm
- > Automation of gate and globe valves



COMBINATIONS WITH GK MULTI-TURN GEARBOXES

- > Torques: up to 16,000 Nm
- > Automation of double-stem gate valves
- > Solutions for special installation conditions



COMBINATIONS WITH GST MULTI-TURN GEARBOXES

- > Torques: up to 16,000 Nm
- > Automation of gate valves
- > Solutions for special installation conditions



COMBINATIONS WITH GHT MULTI-TURN GEARBOXES

- > Torques: up to 120,000 Nm
- > Automation of gate valves with high torque requirements
- > In combination with electrical lifting cylinders: Automation of sluice gates

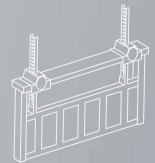

COMBINATIONS WITH LE LINEAR THRUST UNITS

- > Thrusts: 4 kN – 217 Nm
- > Automation of globe valves, spear head adjustment in turbine control

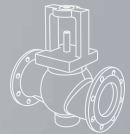

COMBINATIONS WITH GS PART-TURN GEARBOXES

- > Torques: up to 675,000 Nm
- > Not multi-turn: Automation of butterfly valves, ball and plug valves
- > Multi-turn: Automation of lantern gears and toothed racks



COMBINATIONS WITH GF LEVER GEARBOXES

- > Torques: up to 45,000 Nm
- > Automation of butterfly valves with lever arrangements
- > Adjustment of stream deviations and guide vanes in turbine control



ELECTRIC PART-TURN ACTUATORS SQ 05.2 – SQ 14.2

- > Torques: 50 Nm – 2,400 Nm
- > Automation of butterfly valves, ball and plug valves

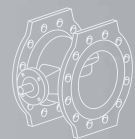

PART-TURN ACTUATORS SQ 05.2 – SQ 14.2 WITH BASE AND LEVER

- > Torques: 50 Nm – 2,400 Nm
- > Automation of butterfly valves with lever arrangements
- > Adjustment of stream deviations and guide vanes in turbine control



AUMA devices are used all around the globe and are subjected to all environmental conditions for providing reliable service meeting the specified life endurance criteria.

AMBIENT TEMPERATURES

Irrespective of the ambient environment - hot or cold - AUMA actuators guarantee reliable service. Various temperature versions are available to suit various ambient environments.

Type of duty	Types	Temperature range	
		Standard	Options
Open-close duty, positioning duty (classes A and B)	SA or SQ	-40 °C ... +80 °C	-60 °C ... +60 °C; 0 °C ... +120 °C
	SA or SQ with AM actuator controls SA or SQ with AC actuator controls	-40 °C ... +70 °C	-60 °C ... +60 °C
Modulating duty (class C)	SAR or SQR	-40 °C ... +70 °C	-60 °C ... +60 °C 0 °C ... +100 °C
	SAR or SQR with AM actuator controls SAR or SQR with AC actuator controls		-60 °C ... +60 °C

Further temperature ranges are possible on request.

SERVICE CONDITIONS



The efficient AUMA corrosion protection is decisive for a high life endurance level of the devices. The AUMA corrosion protection system is based on a chemical preliminary treatment, followed by a two-layer powder coating of the individual components. In compliance with the corrosivity categories according to EN ISO 12944-2, various AUMA corrosion protection levels are provided to suit the different applications.

Colour

The standard colour is silver-grey (similar to RAL 7037). Other colours are available on request.

Classification of environments according to EN ISO 12944-2 Atmospheric corrosivity categories		SA, SQ actuators and AM, AC controls	
		Corrosion protection class	Total film thickness
C1 (very low):	Heated buildings with clean atmospheres	KS	140 µm
C2 (low):	Unheated buildings and rural areas with low level of pollution		
C3 (medium):	Production rooms with humidity and some air pollution. Urban and industrial atmospheres with moderate sulphur dioxide pollution		
C4 (high):	Chemical plants and areas with moderate salinity		
C5-I (very high, industrial):	Industrial areas with almost permanent condensation and with high pollution.		
C5-M (very high, marine):	Coastal and offshore areas with high salinity, almost permanent condensation and with high pollution.		
Corrosivity categories for requirements beyond EN ISO 12944-2			
Extreme (cooling tower):	Coastal and offshore areas with extremely high salinity, permanent condensation and high pollution	KX KX-G (aluminium-free)	200 µm

The AUMA corrosion protection system has been certified with the TÜV Rhineland (Germany).

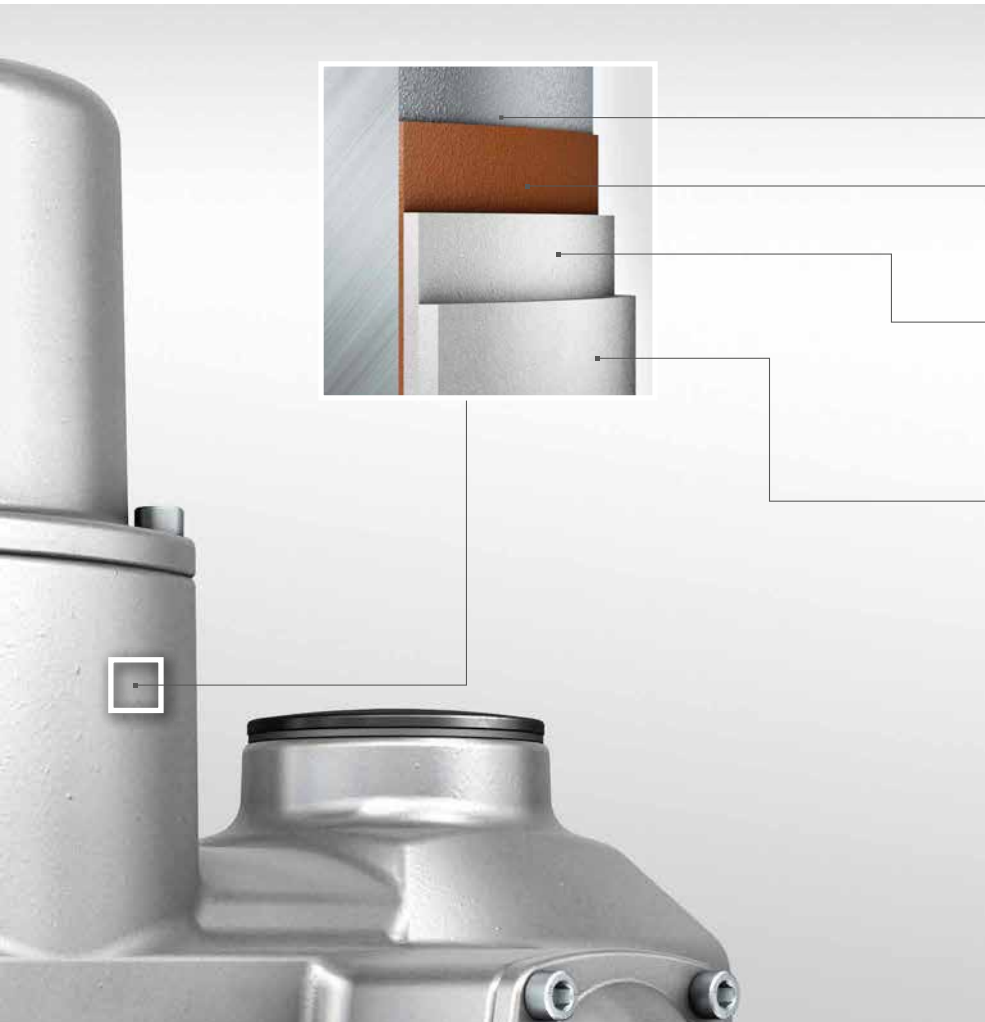

POWDER COATING - COATING STRUCTURE

Housing

Conversion layer

Functional coating to increase paint adherence to the housing surface.

First powder layer

Powder layer based on epoxy resin. The layer ensures optimal adherence between housing surface and finish coating.

Second powder layer

Powder layer based on polyurethane. The layer is a resistance barrier against chemicals, weathering, and UV radiation. The optimal degree of cross-linking of the cured powder results in a significant mechanical resistance. The standard colour is AUMA silver-grey, similar to RAL 7037.

Snow, ice, frost, rain - civil engineering constructions for water applications are intensively and immediately exposed to all environmental elements. They must function reliably under these ambient conditions. This also applies to actuator technology. As from the beginning, AUMA has therefore attached great importance to the AUMA devices being resistant against the most adverse environmental impacts.

ENCLOSURE PROTECTION

IP68 as standard

SA and SQ AUMA actuators are supplied in increased enclosure protection IP68 in compliance with EN 60529. IP68 means protection against continuous immersion up to 8 m head of water for max. 96 hours. During continuous immersion, up to 10 operations are permissible.

Typically, AUMA gearboxes are used in combination with AUMA multi-turn actuators. Gearboxes are also available in enclosure protection IP68. Certain gearboxes are intended for particular applications, e.g. buried service for part-turn actuators or superior immersion levels. Please contact AUMA for device selection with special requirements.

Additional protection towards the housing compartment

The proven AUMA double sealed frame reliably seals the electrical connection to the actuator and prevents ingress of dirt and humidity even when working on the electrical connection. The enclosure protection will not be affected, even if the electrical connection is removed.

The double sealed frame can be combined with any type of electrical connection and can easily be retrofitted.

SERVICE CONDITIONS



For underwater use or in case of potential continuous immersion, AUMA's SA multi-turn actuator with the special continuous underwater feature is the perfect choice.

ACTUATORS FOR CONTINUOUS UNDERWATER USE

Tightly sealed

A sophisticated sealing system combined with excellent corrosion protection properties qualify actuators for underwater use. Double sealed cable glands at the electrical connection, inner seals at all housing covers, some of them coming in pairs, as well as a solid shaft made of stainless steel at valve attachment level protect against ingress of water.

As standard, the actuators are qualified for continuous immersion up to 15 m head of water. Higher heads of water are available on request.

Separately mounted actuator controls

For the non-intrusive version (without opening the actuator housing), all actuator settings are made via AC actuator controls. Actuator controls are separately installed from actuator outside the flooded area and connected via cable to the actuator. Depending on the version, cable lengths up to 100 m can be achieved.

The handwheel is not provided for this actuator version. Underwater applications in combination with AUMA gearbox are also feasible.



UNDERWATER USE

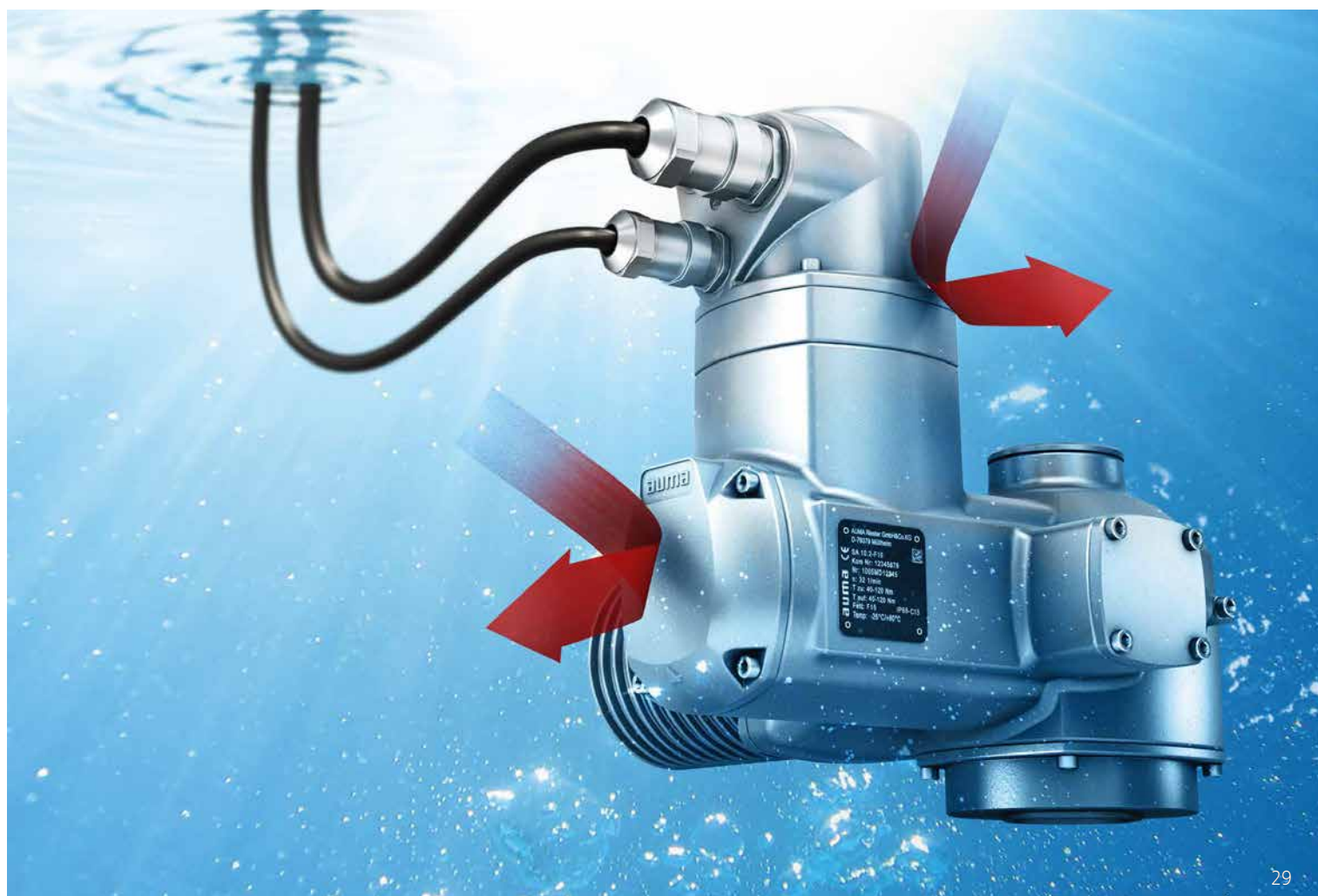

Shut-off and control valves are driven in compliance with the required application and their design. Actuator standard EN 15714-2 distinguishes between three applications:

- > Class A: OPEN-CLOSE duty.
The actuator is required to drive the valve through its entire travel from the fully open position to the fully closed position or vice versa.
- > Class B: Inching/positioning or positioning duty.
The actuator is required to occasionally drive the valve to any position (fully open, intermediate and fully closed).
- > Class C: Modulation or modulating duty.
The actuator is required to frequently drive the valve to any position between fully open and fully closed.

Switching frequency and motor operation mode

Modulating duty and open-close duty subject the actuator to different mechanical loads. Consequently, special actuator types are available for each operation mode.

The types of duty for actuators in compliance with IEC 60034-1 and EN 15714-2 (also refer to page 71) are typical distinction criteria. For modulating duty, additional indication is made of the permissible number of starts.

Actuators for open-close duty and positioning duty (classes A and B or types of duty S2 - 15 min/30 min)

AUMA actuators for open-close and positioning duty are identified by type designations SA and SQ:

- > SA 07.2 – SA 16.2
- > SA 25.1 – SA 48.1
- > SQ 05.2 – SQ 14.2

Actuators for modulating duty (class C or types of duty S4 - 25 %/50 %)

AUMA actuators for modulating duty can be identified by type designations SAR and SQR:

- > SAR 07.2 – SAR 16.2
- > SAR 25.1 – SAR 30.1
- > SQR 05.2 – SQR 14.2

Special dimensioning is always possible. Depending on the actual application, virtually all types of duty can be carried out for dimensioning.

BASIC ACTUATOR FUNCTIONS

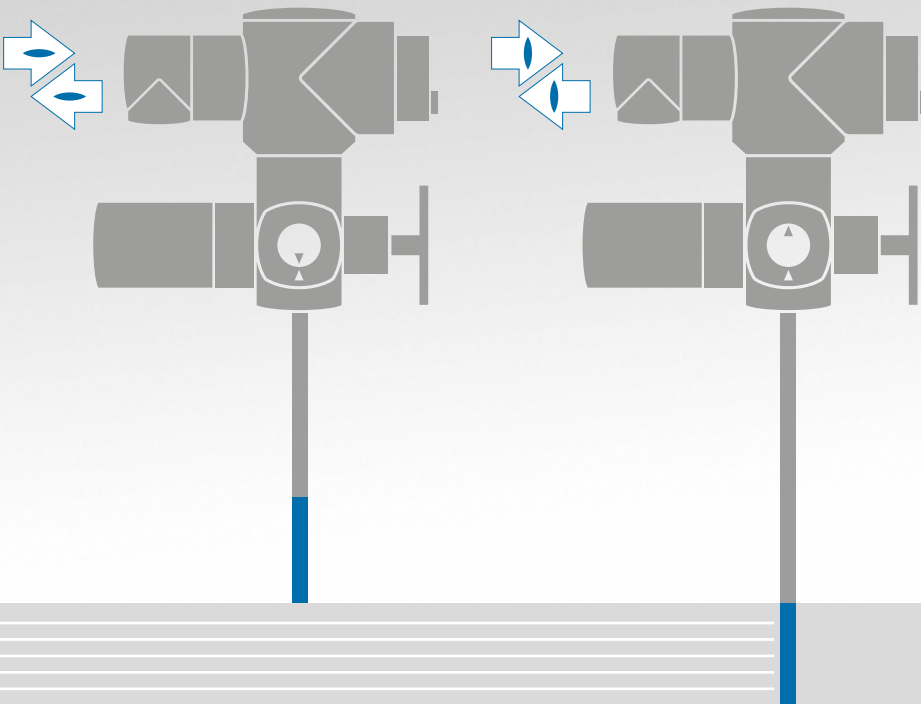

OPEN - CLOSE control

This is the most typical type of control. During operation, control commands Run OPEN and Run CLOSE as well as feedback signals End position OPEN and End position CLOSED are usually sufficient.

Automatic switching off is made either via limit seating or torque seating.

An actuator will be switched off once the end position or the intermediate position is reached. Two switch-off mechanisms are available and applied depending on the type of application.

> **Limit seating**

As soon as the preset switching point in one end position is reached, the controls automatically switch off the actuator.

> **Torque seating**

As soon as the preset torque is applied at the end position, the controls automatically switch off the actuator.

This seating type is also used as protective function for limit seating to prevent damage due to excessive torque.

EMERGENCY MANUAL OPERATION

As standard, electric actuators are equipped with a handwheel. It is used to manually approach the end positions during commissioning.

Furthermore, the actuator can be operated via handwheel in case of power failure.

Solutions with and without self-locking

Actuators counteract torques affecting the output side with a load. If this load means that the position of the closing element cannot be moved from standstill when applying force, this is called self-locking.

Most AUMA actuators are self-locking as standard. However, variants can be supplied to specifically be non self-locking allowing them to operate close under gravity.

Self-braking

Self-braking occurs if the closing element reaches absolute standstill after actuator cut-off while in motion.

For some actuator-gearbox combinations, this requirement can also be met by using a brake motor.

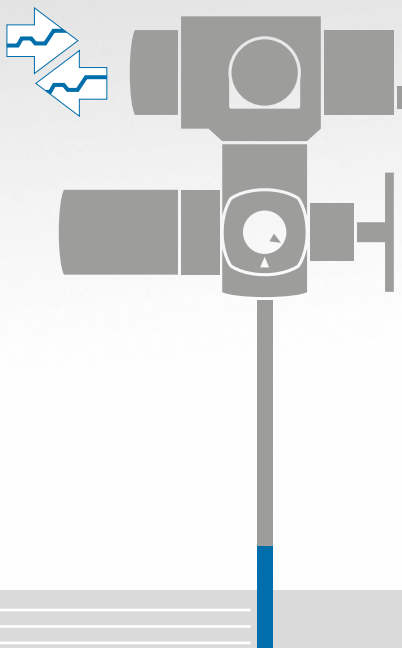

Setpoint control

Controls receive a position value from the host DCS, e.g. as 0/4 – 20 mA signal. The integral positioner compares this value with the current valve position and operates the actuator until actual value equals setpoint. The valve position is transmitted to the DCS.

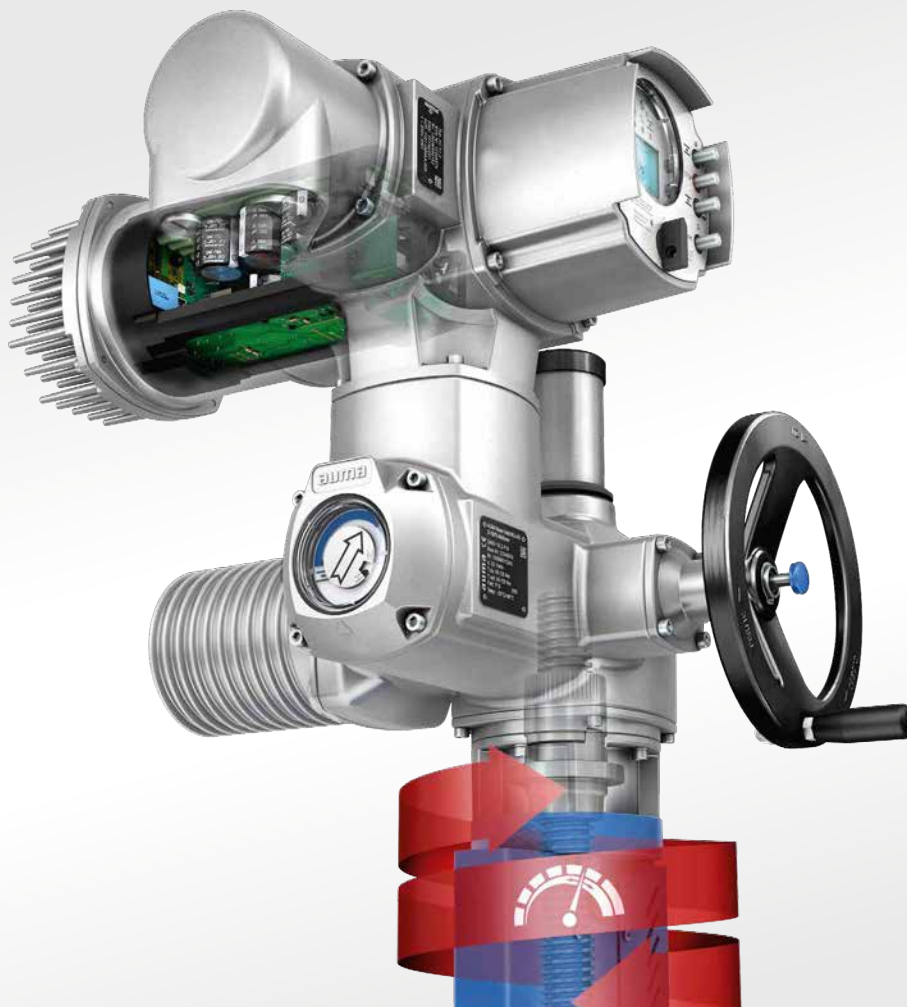

VARIABLE SPEED ACTUATORS

The proven AUMA SA/SAR range is enhanced by variable speed models. SAV multi-turn actuators for open-close duty and SARV multi-turn actuators for modulating duty are paired with intelligent ACV .01.2 actuator controls.

Variable speed offers significant advantages. For any change of valve position, the best possible operating speed is adjustable.

ACV 01.2 actuator controls have the best of both worlds: full functionality of the standard AC 01.2 while providing additional functions for variable speed actuators:

Soft start and soft stop

Operations out of an end position start at zero speed. By means of a ramp function, speed is increased until the predefined setpoint value is reached. Soft stop is the exact opposite: Prior to reaching the end position, the speed is decreased. The advantage is gentle service for all valve and actuator components subject to wear.

Superior positioning accuracy

Like for operation into the end position, the actuator decreases the operating speed when approaching the setpoint valve position down to standstill. This allows for more accurate actuator positioning to the setpoint compared to the sudden tripping of a fixed speed actuator. This ability is particularly crucial for the SARV modulating duty model.

Speed profile with up to ten speed pivot points

Specified speed values can be set for up to ten pivot points depending on the direction of operation. Thus a valve specific speed profile can be defined via travel. Typically, this function is desired for avoidance of pressure surges when closing valves in pipework.

EMERGENCY operation at predefined speed

EMERGENCY operations are executed at a predefined and frequently high speed to suit the particular event.

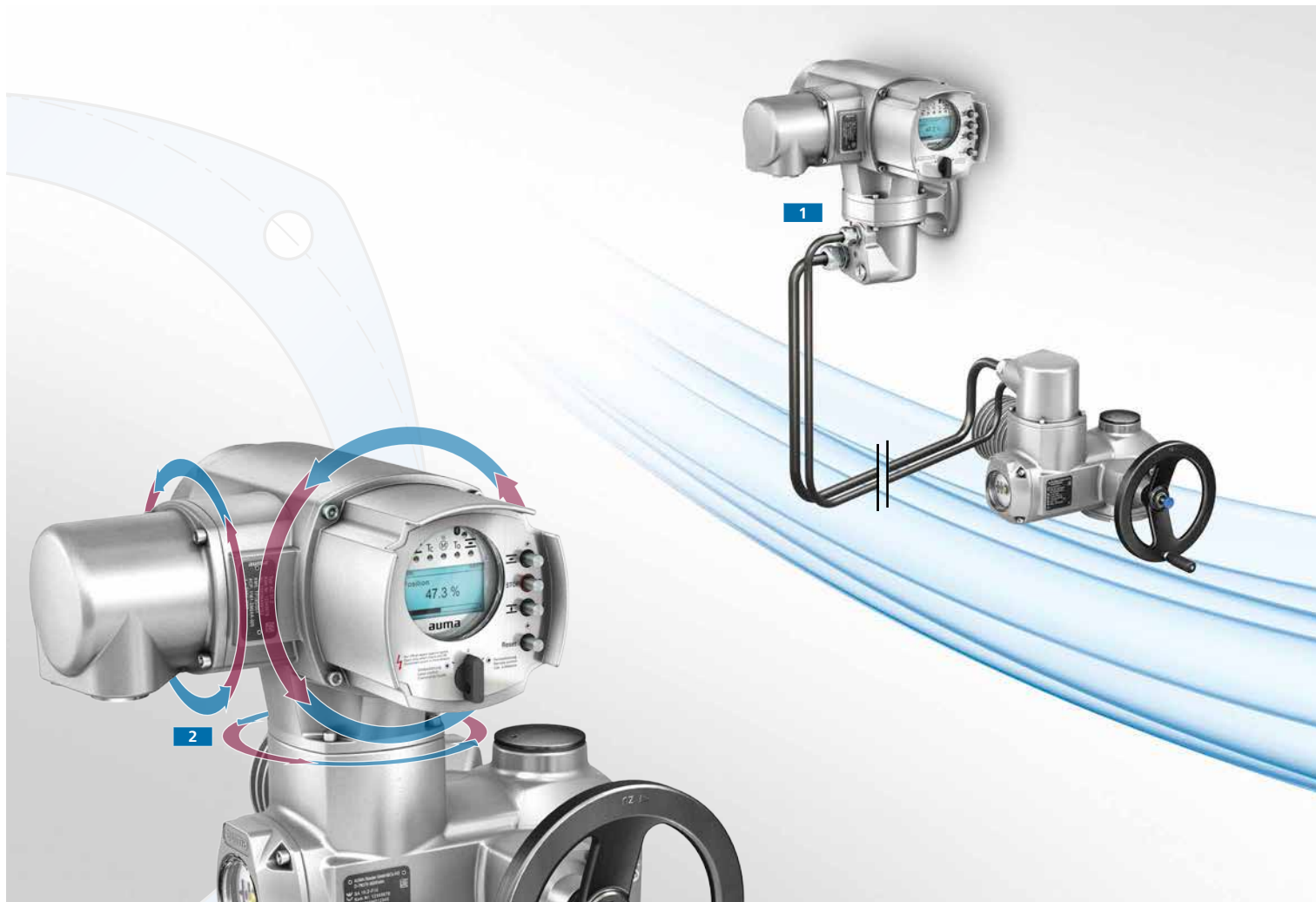

ADAPTING TO THE INSTALLATION ON SITE

One of the many advantages of a modular design is the ease at which device configuration upgrade on site can be achieved.

1 Wall bracket

If required, actuator controls can be mounted separately from the actuator on a wall bracket. This is recommended in particular for installation sites where actuators access is difficult, strong vibration or potential danger of vandalism. For underwater applications, actuator controls are also mounted separately from the actuator. The cable length between actuator and controls may be up to 100 m. The wall bracket may easily be retrofitted at a later date.

2 Customisation of device positioning

The optimum positioning is easily adjustable thus avoiding the display being upside down, inaccessible operating elements, awkward cable gland alignments, etc. The correct position can easily be chosen.

The following positioning adjustments at 90° increments are possible: controls to actuator, local controls to controls as well as the electrical plug/socket connector. The plug/socket connections allow easy on-site adjustment of the mounting position.

Mounting positions of actuator and gearbox

If AUMA actuators are ordered in combination with gearboxes, both devices can be mounted in four different positions, each rotated by 90°. Later adaptation on site is also possible. This applies to all AUMA multi-turn, part-turn, and lever gearboxes.

Separate documents describing the mounting positions are available for all gearbox types.

OPERATION ELEMENTS FOR MANUAL OPERATION

Actuators cannot always be accessed easily. Special applications demand special challenges. Some application examples with the AUMA solutions are described below.

1d Chain wheel with remote switch-over
Activation via pull rope, scope of delivery without chain.

1 Optional elements for manual operation

1a Handwheel extension

For separate mounting of handwheel



1b Adapter für power tool emergency operation

For manual emergency operation using a power tool



1c Pit application with square head for power tool operation

Activation via square head power tool



ADAPTING TO THE INSTALLATION ON SITE



All examples illustrate how to use the items shown.

2 Installation in pits

Flooding and accessibility of the operation elements - depending on the importance of these factors - result in different installation requirements.

2a Floor pedestal

GS part-turn gearbox is mounted to the valve, the multi-turn actuator is easily accessible due to the AUMA floor pedestal. Power transmission between actuator and gearbox is made via a cardan shaft.

2b Pit application with square head for power tool operation

GS part-turn gearbox is mounted to valve, the multi-turn actuator is mounted separately from the gearbox. To make sure that actuator and gearbox flanges are aligned, a GK bevel gearbox is used. Emergency operation is performed from the manhole cover. For this purpose, the actuator is equipped with an extension for pit installations. The end is made as square head to allow power tool operation. The manual emergency operation is activated by pushing on the power tool square head.

3 Synchronous operation - double-stem gate valves

In this application, it is of utmost importance to operate both stems simultaneously to avoid jamming the plate. The solution: Each stem is equipped with one GK bevel gearbox **3b**, both driven by an SA multi-turn actuator **3a**. In the example, the actuator is directly mounted to a gearbox, torque transmission to the second gearbox is performed via a shaft. Handwheel extensions **3c** make manual emergency operations much easier.

4 Manual emergency operation at a weir

Typically, weirs require adaptations to the special installation conditions. Actuators might be difficult to access. The chain wheel solutions including the switch-over function is a perfect solution for manual emergency operation, even in these difficult environments.

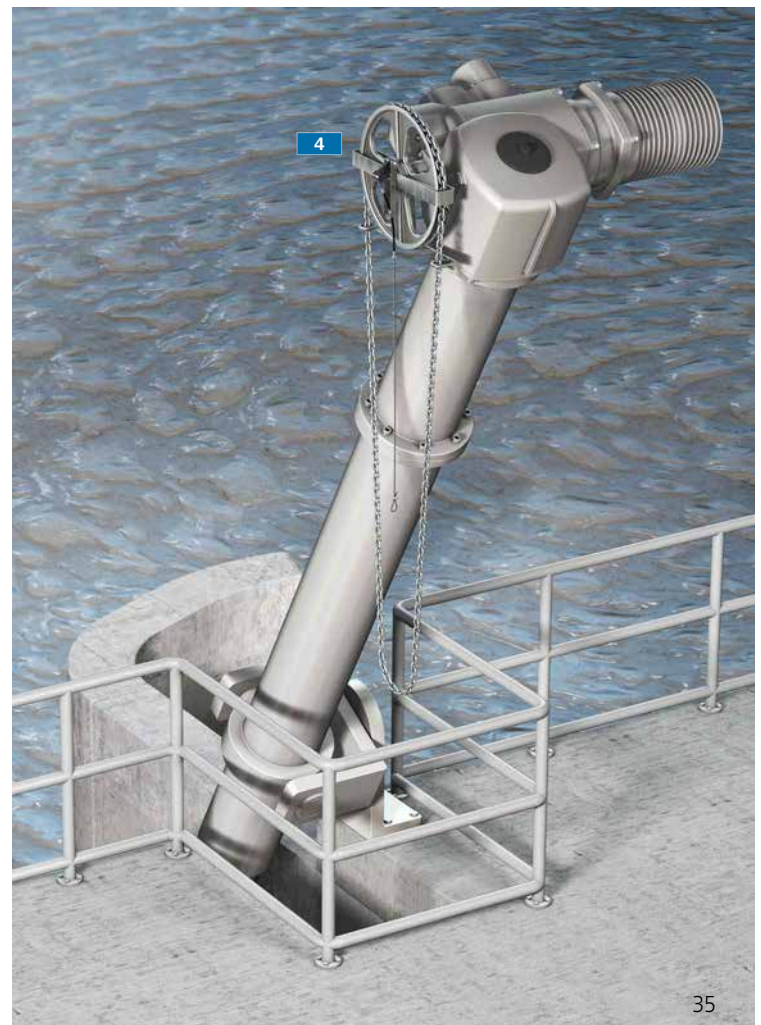
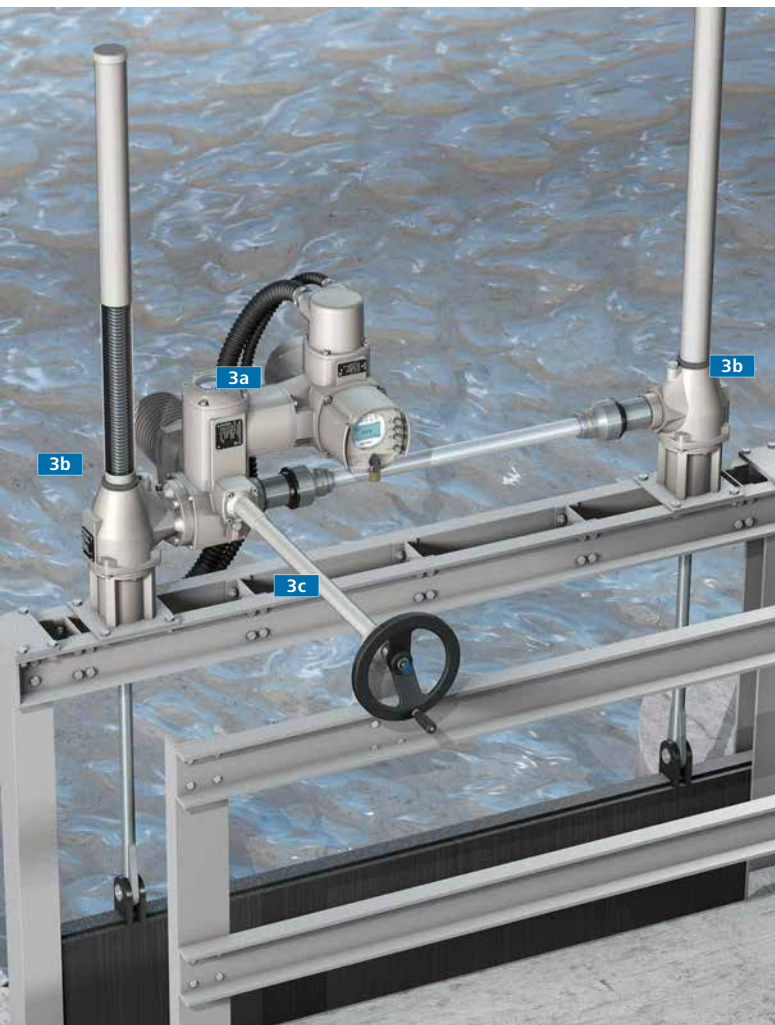

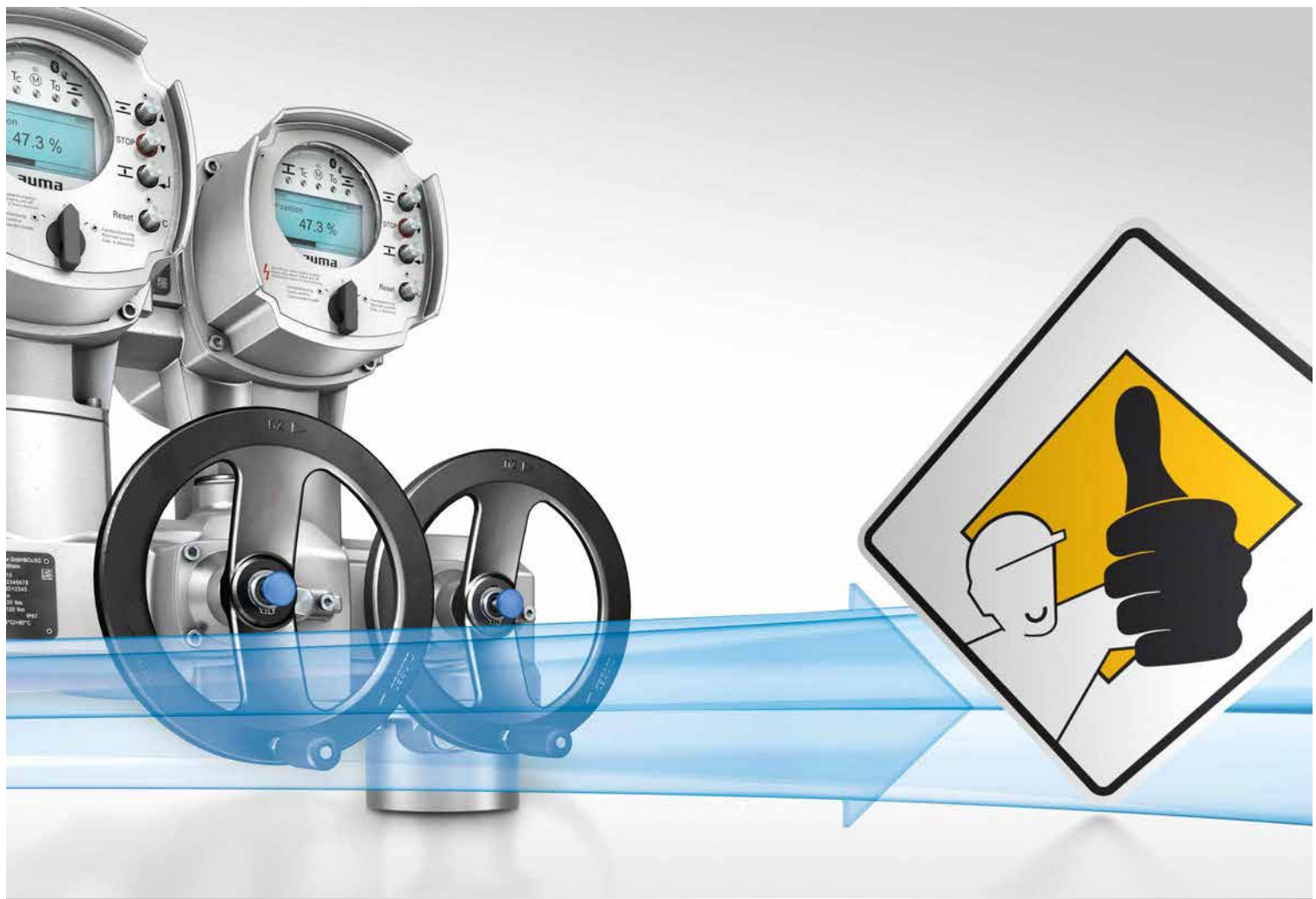

PROTECTION FOR THE VALVE, PROTECTION FOR THE ACTUATOR

AUMA actuators comply with global safety standards. They are equipped with a large variety of functions for safe and orderly operation while protecting the valve.

Correction of the direction of rotation

The automatic correction of the direction of rotation upon wrong phase sequence is an integral feature of the controls. If the phases are mixed up when connecting the three-phase supply, the actuator still travels in the correct direction when receiving the respective operation command.

Valve overload protection

If an excessive torque is applied during travel, e.g. due to a trapped object within the valve, the controls switch off the actuator to protect the valve.

Protection tube for rising valve stem

The protection tube encloses a rising valve stem, thus protecting the stem against contamination and the plant operators against injury.

Thermal motor protection

AUMA actuators are equipped with thermostats or PTC thermistors within the motor windings. They trip as soon as the temperature within the motor exceeds 140 °C. Embedded within the controls, they optimally protect the motor winding against overheating.

Thermostats or PTC thermistors offer better protection than thermal overload relays since the temperature rise is measured directly within the motor winding.

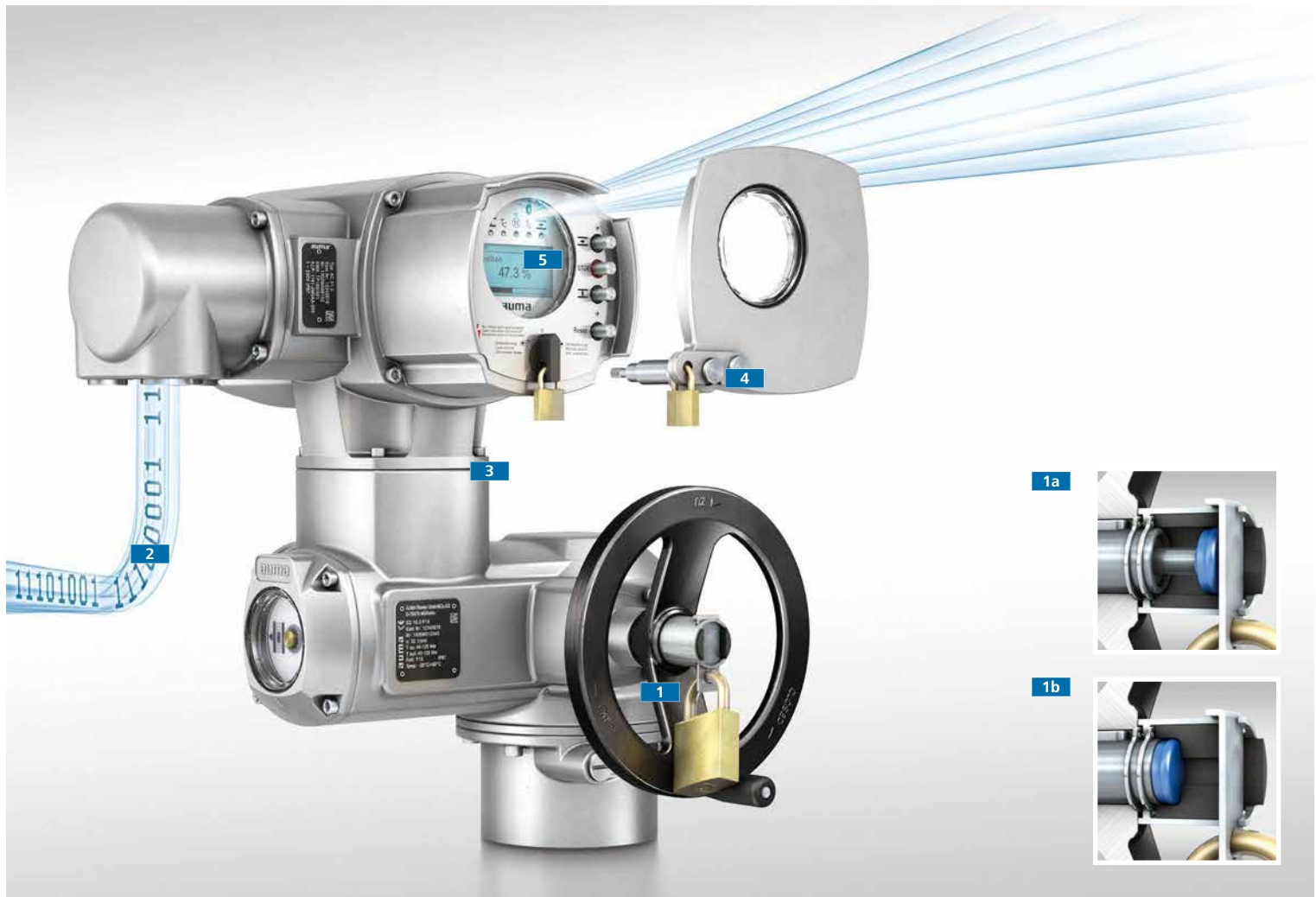

PROTECTION AGAINST UNAUTHORISED USE

AUMA actuators are not exclusively installed in buildings or on company premises but are sometimes freely accessible to third parties. AUMA products can be equipped with a certain number of options preventing unauthorised operation of the actuators.

- 1 Locking device for handwheel**
 Activation of manual operation can be inhibited by means of a locking device. **1a** On the other hand, it is possible to inhibit automatic switching to motor operation once manual operation has been activated **1b**.
- 2 Remote enabling of AC local controls**
 Electrical actuator operation via the local controls is not possible without the enable signal from the control room.
- 3 Lockable selector switch**
 The selector switch for selecting the control mode can be protected against operation in all three positions: LOCAL, OFF, and REMOTE.
- 4 Lockable protection cover**
 Protects all operation elements from vandalism and unauthorised operation.
- 5 AC Bluetooth connection**
 Password entry is required to establish a connection between a laptop or PDA and an actuator with integral controls.

Password protection for AC device parameters

Device parameters may only be changed after password entry.

Functional safety is a topic of increasing importance in the context of safety of technical systems – supported by the issue of new international standards.

AUMA as a manufacturer of actuators used in safety-related systems has been involved with this issue for many years. Our solutions provide safety in accordance with the relevant international standards.

Functional safety comes into play whenever failure of a system would incur major risks for both people and the environment. Safety instrumented systems (SIS) activated on demand and preventing damage to people, the environment or property will be installed to reduce risks.

International standards on functional safety

Depending on the application, different standards on functional safety apply. IEC 61508 and IEC 61511, relevant to process industry, chemical and petrochemical industry, are widely applied on an international level. These standards classify safety requirements in accordance with safety integrity levels SIL 1 to SIL 4, where SIL 4 represents the highest level.

ISO 13849 on Safety of machinery uses a classification according to performance levels (PL). PL is a measure for reducing the risk arising from the machine. Performance levels are classified from "a" to "e" whereas e represents the highest PL.

FUNCTIONAL SAFETY



Design of a safety instrumented system

In general, a safety instrumented system (SIS) consists at least of the following components:

- > Sensor **1**
- > Controls (safety PLC) **2**
- > Final element, in our example consisting of an electric actuator **3** and a control or shut-off device **4**

Functional safety gains importance in civil engineering constructions for water applications and hydropower applications. The current edition of the German DIN 19704-3:2014 stipulates safe end position feedback for specific applications in hydraulic steel structures in Germany, complying with the requirements of performance level b in accordance with ISO 13849. Demand for the safety functions safe OPENING, safe CLOSING and safe STOP is continuously growing.

Safe end position feedback

For this safety function, the actuator is used as sensor within the SIS, issuing a safe signal as soon as one of the end positions OPEN or CLOSED or the tripping torque have been reached.

The safe end position feedback function of AUMA actuators was checked by the independent certification agency exida: PL c can be achieved which even exceeds the requirements of DIN 19704.

Safe OPENING/Safe CLOSING (Emergency Shutdown, ESD)

Actuator and valve form the final element within the safety instrumented system. The actuator travels in direction end position OPEN or end position CLOSED on demand for safety function.

Safe standstill/Safe STOP

In this case, actuator and valve also act as final element within the SIS. Upon request of the safety function, the actuator motor is stopped. Undesired motor starts are prevented.

Application example of a lock

Locks are the ideal example for presenting the different safety functions:

For instance, it has to be ensured that the lock gates on one side are completely closed prior to opening the other side. This can be monitored by an actuator with safe end position feedback.

If a ship is between the opened lock gates, the Safe STOP safety function can reliably stop the closing of the lock. The Safe STOP safety function can also be used as interlock function. In this case, movement of the lock gate can only be started if the "Safe STOP" signal is not applied

Safety due to assessment by independent bodies

For plant designers and plant operators, it is of core importance to exclusively implement components meeting the respective safety requirements of safety-related systems.

Functional safety of AUMA actuators, actuator controls and gearboxes has been comprehensively tested and assessed by independent and internationally accredited certification agencies to support our customers in sizing their systems.

The result: Currently, we offer a wide range of actuator solutions for various safety requirements, typically up to SIL 2 (in accordance with IEC 61508/61511) or PL c (in accordance with ISO 13849). While considering further requirements, such as redundant system structure, solutions achieving SIL 3 or PL d might also be possible.

Our specialised colleagues will be glad to assist you in selecting suitable actuators. Furthermore, we provide comprehensive documentation such as safety figures and test reports.



Actuators



SA NORM



SA - AM



SA - AC

System components



Connection terminals



Fuse protection



Controls



Switchgear



Local controls

Cables



Power supply



L1, L2, L3, PE



Parallel wiring



Output contacts, signal inputs and outputs



Serial wiring



Fieldbus



Number of cable wires



3

Control concept efforts

Planning efforts

Installation efforts

Commissioning efforts

Documentation efforts

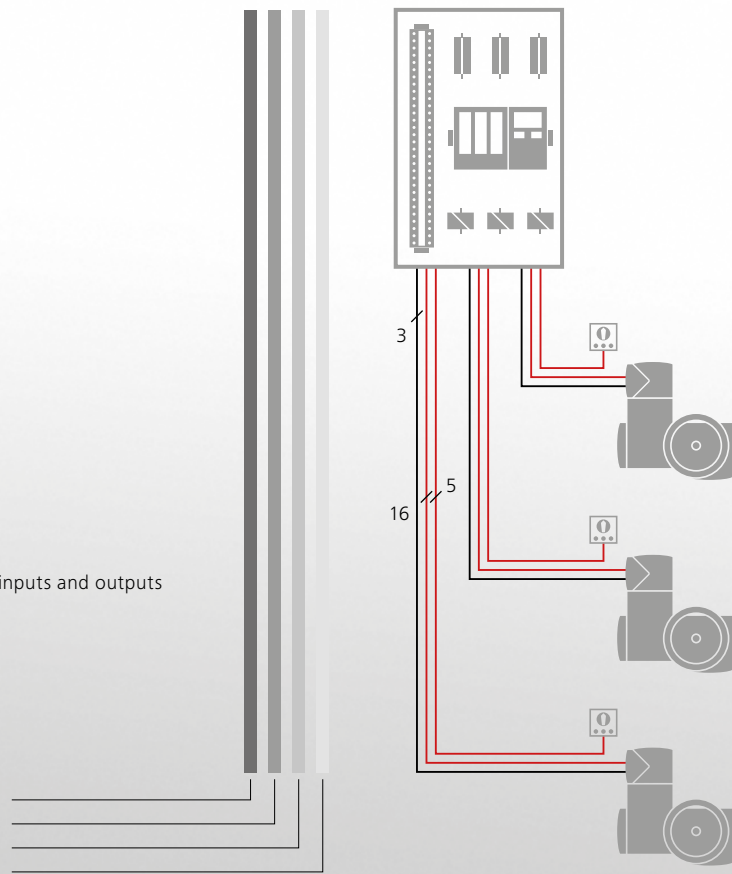

INTEGRATION INTO THE DCS - CONTROL CONCEPTS

AUMA actuators can be integrated into any automation system. Product selection in favour of actuators with integral controls saves time-consuming project planning, installation, and additional documentation which is required when selecting external controls. A further benefit in favour of integral controls is easy commissioning.

External controls

For this controls concept, all actuator signals such as limit switch signals, torque switch signals, motor protection and valve position (if required) are transmitted to an external control system and further processed. When designing controls' architecture, care must be taken to consider the required protective mechanisms and to minimise delay time.

Switchgear for motor controls is installed within a control cabinet and wired accordingly to the actuator.

If local controls are required, they have to be installed in vicinity of the actuator and integrated with external controls.

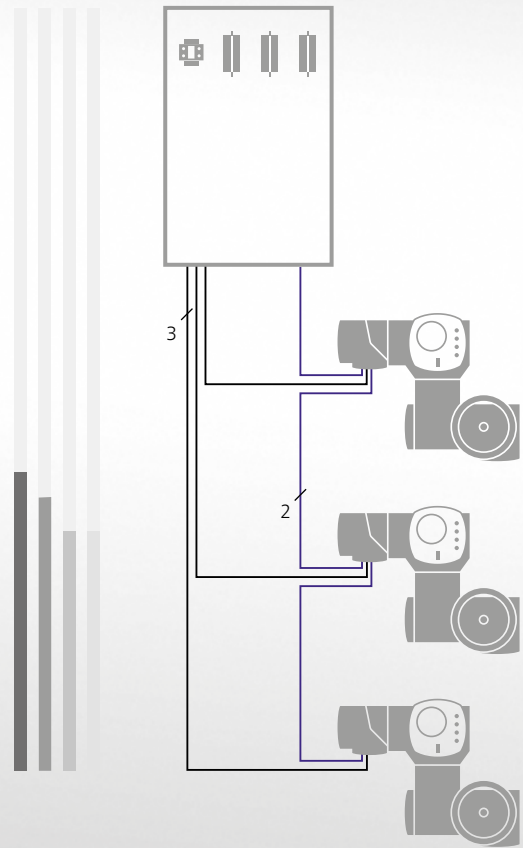
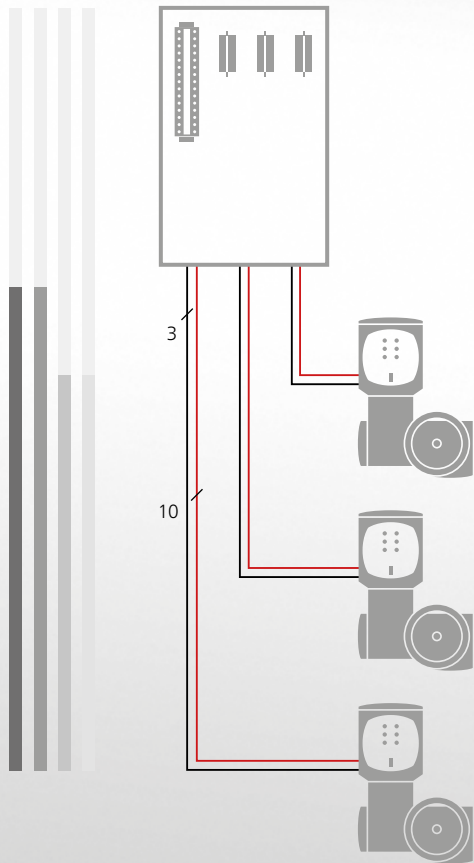

Integral controls

Installation costs for integral controls are considerably lower. Once the power supply is established, the actuator is ready for use. The actuator can be operated via the operation elements on the local controls. The controls are perfectly adapted to the actuator.

The actuator can be completely set locally, without requiring direct connection to the DCS. Only operation commands and feedback signals are exchanged between the control system and the actuator. Motor switching is performed within the device and virtually without delay.

AUMA actuators are available with AM or AC integral controls.

Fieldbus

In fieldbus systems, all actuators are linked to the DCS via conventional 2-wire cables. All operation commands and feedback signals between actuators and DCS are exchanged by means of these cables.

Input and output sub-assemblies become obsolete when applying fieldbus wiring thus reducing space requirements within the control cabinet. Use of two-wire cables simplifies commissioning and saves cost in particular if long cables are required.

A further advantage of fieldbus technology is that additional information on preventive maintenance and diagnostics can be transmitted to the control room. Thus, fieldbus technology forms the basis for integrating fieldbus devices within Asset Management Systems supporting safeguarding of plant availability.

AUMA actuators with AC integral actuator controls are available with interfaces to all typical fieldbus systems within process automation.

The mechanical interface to the valve is standardised. Interfaces to the control system undergo continuous development.

Parallel control, fieldbus, or both for reasons of redundancy? When opting for fieldbus, which protocol to use?

Irrespective of your decision on the interface, AUMA actuators can be equipped with the suitable interface to match all systems established within process control engineering.

Actuator commands and signals

In simple applications, operation commands OPEN and CLOSE, feedback signals End position OPEN/End position CLOSED reached as well as Collective fault signal suffice. Any isolating valve can be reliably operated with these five discrete signals.

If the valve position control is required or if a desired intermediate position is to be approached in positioning duty, further continuous signals are required: Position setpoint and Position feedback signal (actual value), typically a 4 – 20 mA analogue signal for communication via parallel interface.

In addition, intermediate positions can be programmed via the integral actuator controls. Consequently, actuator controls approach the subsequent programmed position automatically upon the next operation command.

Fieldbus protocols expand the bandwidth for information transmission. Further to transmission of commands and feedback signals required for operation, access to all device parameters and operating data via fieldbus from the DCS is made available.

COMMUNICATION - TAILOR-MADE INTERFACES



AM

All inputs and outputs are hard wired, as detailed on the terminal plan.

- > Three digital inputs for the control commands OPEN, STOP, CLOSE
- > Five digital outputs with the following functions: End position CLOSED, end position OPEN, selector switch in REMOTE, selector switch in LOCAL, collective fault signal
- > As an option, an analogue 0/4 – 20 mA output for remote position indication.

The digital inputs and outputs are potential-free, the analogue output is galvanically isolated.

AC

Signal assignment of outputs can be modified at a later date via AC device setting. Depending on the version, AC controls provide:

- > Up to six digital inputs
e.g. operation commands OPEN, STOP, CLOSE, enable signals for local controls, EMERGENCY commands, etc.
- > Up to ten digital outputs
e.g. for feedback of end positions, intermediate positions, selector switch position, failures, etc.
- > Up to two analogue inputs (0/4 – 20 mA)
e.g. for setpoint reception to control the positioner or PID controller
- > Up to two analogue outputs (0/4 – 20 mA)
e.g. for feedback of valve position or torque

The digital inputs and outputs are potential-free, analogue outputs are galvanically isolated.

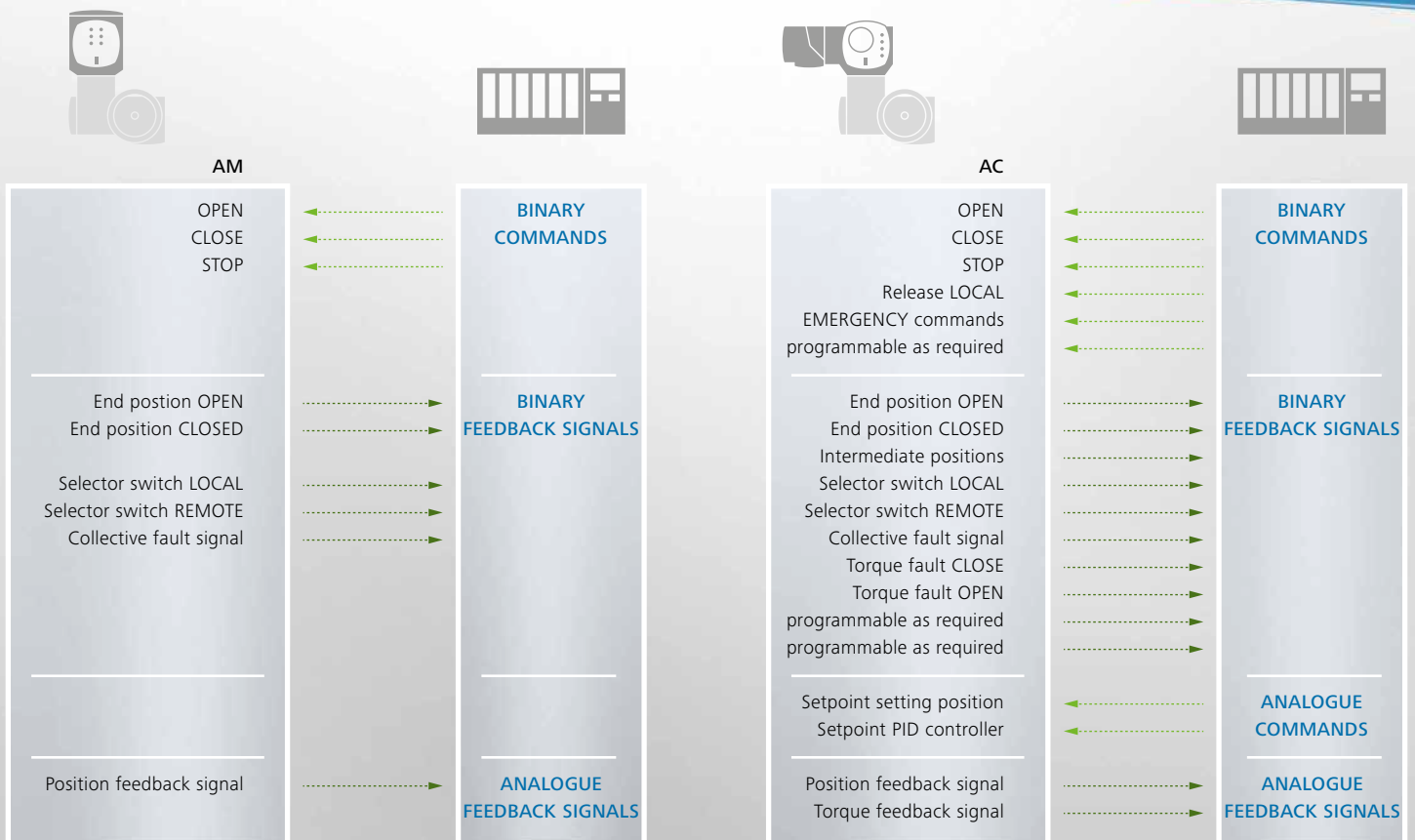

Cost reduction is one of the main statements in favour of fieldbus technology. In addition, introduction of serial communication in process automation has proven as an innovation driver for field devices and consequently for actuators. Concepts for efficiency gains such as remote parameterisation or Plant Asset Management would not be feasible without the fieldbus technology. AUMA actuators equipped with fieldbus interfaces are state of the art.

FIELDBUS PROTOCOLS

Many different fieldbus systems are available on the market. Certain preferences have evolved on a regional level or specific to certain plant applications. Since AUMA actuators are implemented in all types of technical process plants around the globe, they are available with any communication system established in this industry.

- > Profibus DP
- > Modbus RTU
- > Foundation Fieldbus
- > HART and WirelessHART

Industrial Ethernet

- > Profinet
- > Modbus TCP/IP

Overall, AUMA devices are available with digital and analogue inputs to connect additional sensors to the fieldbus.

COMMUNICATION - FIELDBUS

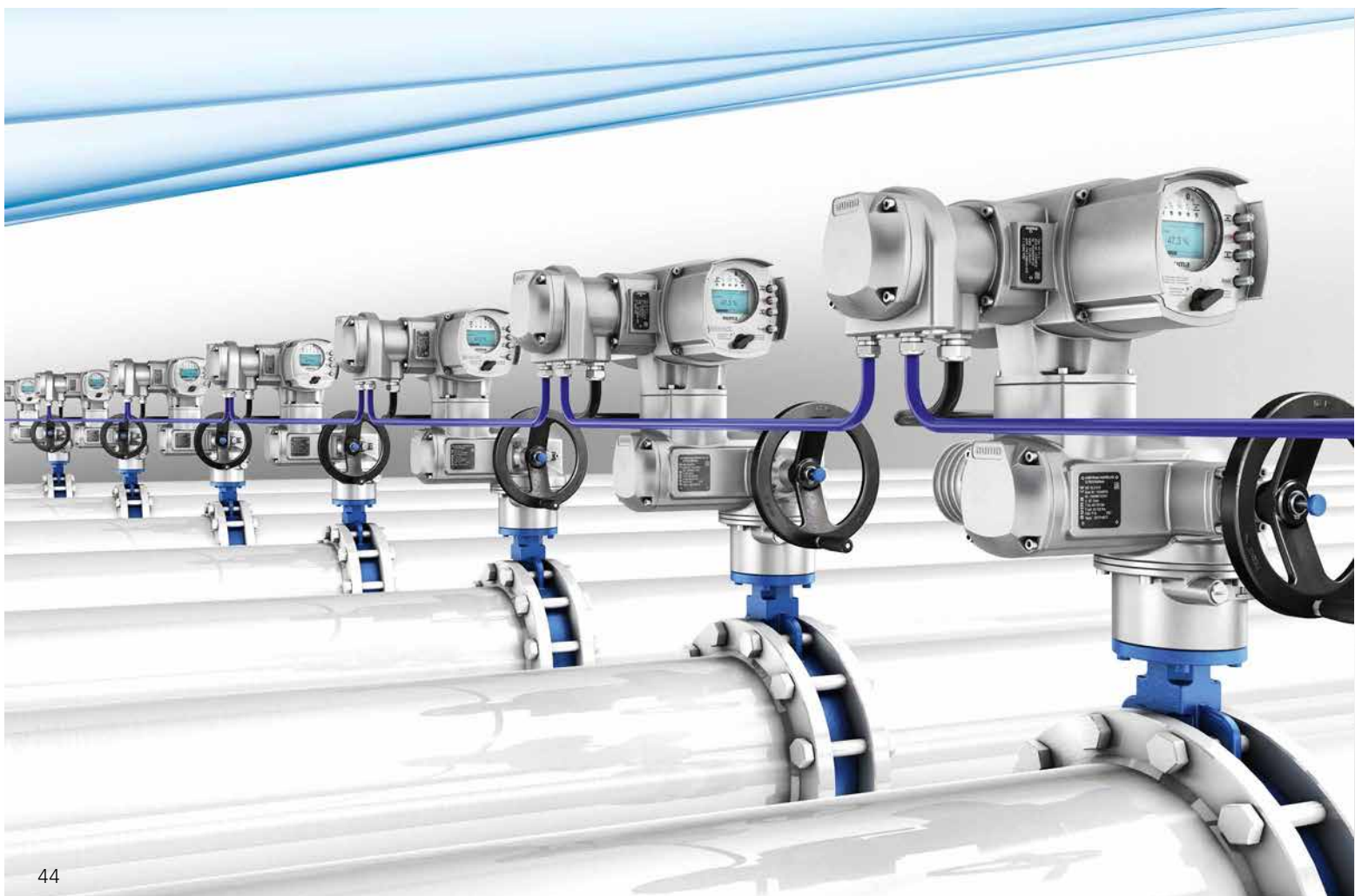

EDD and FDT/DTM are two independent technologies for harmonisation of device integration within fieldbus systems across all field devices. This includes for example device configuration, device replacement, fault analysis, device diagnostics, or documentation of these actions. For this reason, EDD and FDT/DTM are crucial for Plant Asset Management and Life Cycle Management of a plant.

Besides the imperative main functions, field devices possess diagnostic functions and many specialised application functions to adapt the device to the process and environmental conditions as required. If certain prerequisites are fulfilled, for Profibus e.g. the DP-V1 protocol, data exchange connected to these functions can directly take place between control station and field device via fieldbus. For AUMA actuators, this further includes status and diagnostic signals in compliance with NAMUR NE 107, parameter modifications of user functions, information of the electronic device ID or operational data for preventive maintenance.

EDD or FDT/DTM is used to harmonise access from the control station to the data available with the various field devices.

EDD

Each field device supporting this technology is provided with an EDD (Electronic Device Description). This file combines device parameters described in ASCII using standardised and platform neutral EDD language. This technology helps to create a uniform user philosophy with identical parameter visualisation across all field devices.

FDT/DTM

FDT (Field Device Tool) is a software interface definition to integrate DTM (Device Type Manager) into the FDT system of the maintenance processor. DTM is a software module supplied by field device manufacturers. Similar to a printer driver, DTM is installed within the FDT frame application to visualise settings and information available from the field devices.

You may download available EDDs and DTMs for AUMA actuators at: www.auma.com.

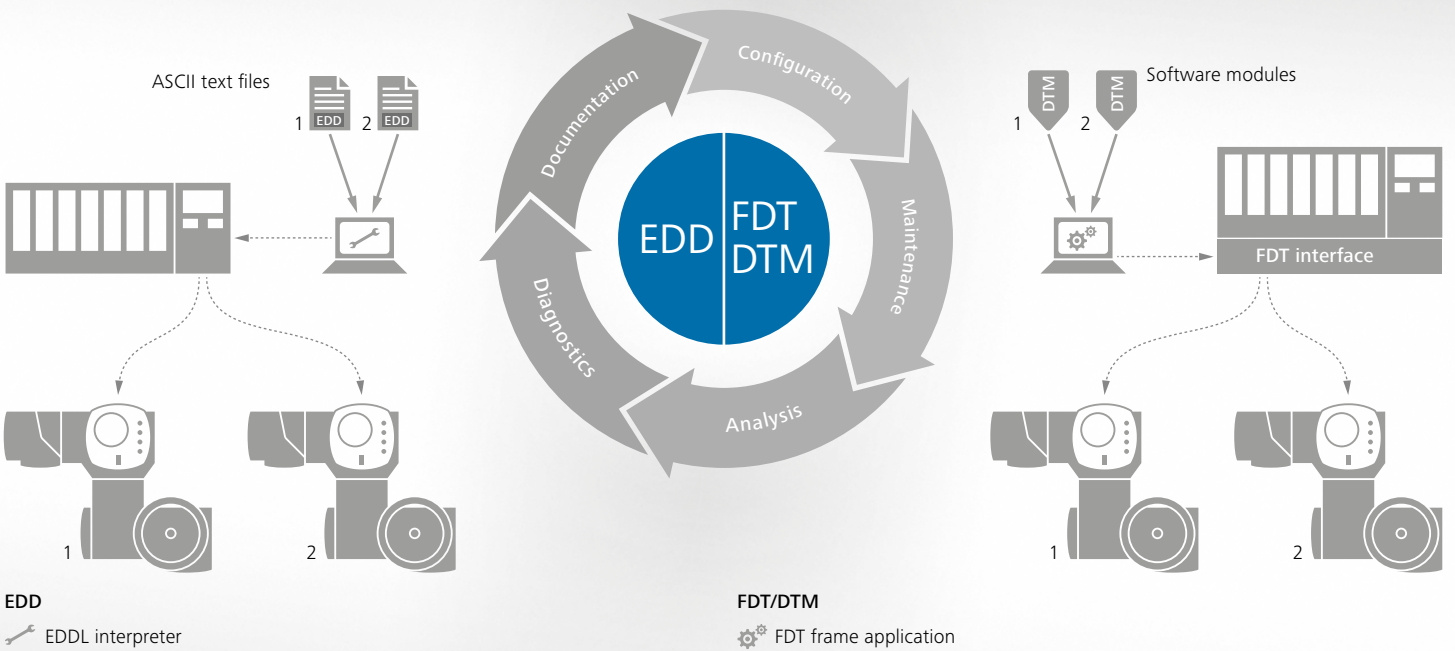

Comparison of functional scope

EDD	
FDT/DTM	



AM AND AC ACTUATOR CONTROLS

Integral controls evaluate the actuator signals and operation commands and switch the motor on and off without delay, using the installed reversing contactors or thyristors.

After analysis, the controls supply the actuator signals as feedback signals to the host level.

The integral local controls allow for local actuator operation.

AM and AC controls can be combined with both SA and SQ actuators. This creates a homogeneous picture for the DCS.

Please refer to page 75 for a detailed overview of the controls' functions.

AM 01.1 AND AM 02.1 (AUMA MATIC)

AM controls with simple design and defined features are the perfect choice when using parallel signal transmission and if a relatively low number of feedback signals is required.

Few parameters need to be defined via sliding switches during commissioning, e.g. type of seating in end positions.

Actuator control is made via operation commands OPEN, STOP, CLOSE. Reaching an end position and collective fault signals are reported back to the DCS as feedback signals. These signals are visually displayed at the local controls via the indication lights. As an option, the valve position can be transmitted as 0/4 – 20 mA signal to the DCS.



AC 01.2 (AUMATIC)

AC controls are your perfect solution if the application requires self-adapting control functions, data logging, configurable interface or if valve and actuator are to be integrated into a Plant Asset Management System due to advanced diagnostic functions.

AC controls are equipped with a parallel interface for free configuration and/or interfaces to fieldbus systems as used within process automation.

The diagnostic functions comprise a time-stamped event report, torque characteristics logging, continuous recording of temperatures and vibration within the actuator and, furthermore, counting the number of starts and motor running times.

Further to the basic functions, AC controls offer a number of options to meet special demands. These include torque by-pass to unseat valves if tightly seated or functions for extending operating times to avoid water hammer within pipelines.

With the development of the AC 01.2, particular emphasis was laid on user-friendliness and the ease of integration of actuators into the DCS. The large graphic display is used to perform menu-controlled programming of the controls, optionally using AUMA CDT (refer to page 52) via wireless Bluetooth connection. For fieldbus connections, AC programming can be performed from the control room.



CLEARLY STRUCTURED OPERATION

Modern actuators can be adapted to special application requirements by a multitude of parameters. Monitoring and diagnostic functions generate signals and collect operating parameters.

For AC actuator controls, accessing the considerably more detailed data is facilitated by a clearly structured and intuitive user interface.

All device settings can be performed without requiring any additional parameterisation tool.

The display structure is user-friendly, in plain text and available in a large number of languages.

Password protection

The AC password protection is an important safety function. This feature prevents non-authorized persons from modifying defined settings.

1 Display

The graphic display shows texts and graphic elements as well as characteristics.

2 Indication lights

Visual status signals via indication lights can be programmed. Signals indicated via LEDs are clearly visible even from longer distances.

3 Selecting the control mode

The selector switch LOCAL - OFF - REMOTE is used to define whether the actuator is operated from remote (Remote control) or via the local controls (Local control).

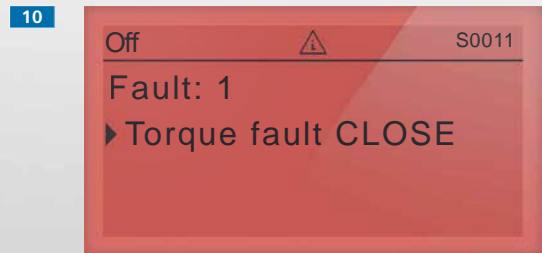
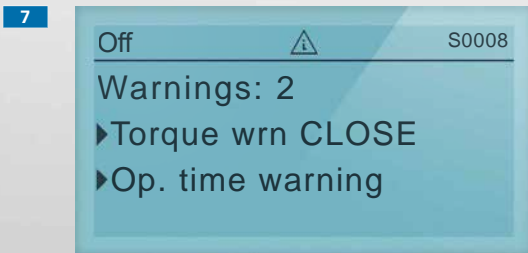
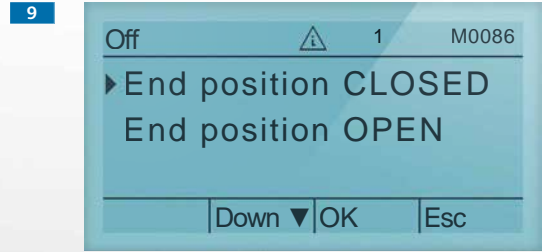
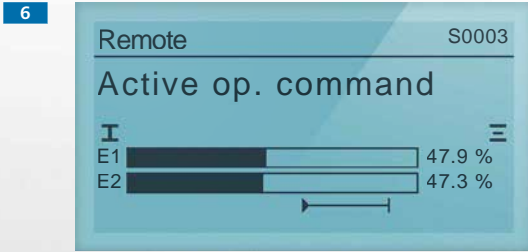
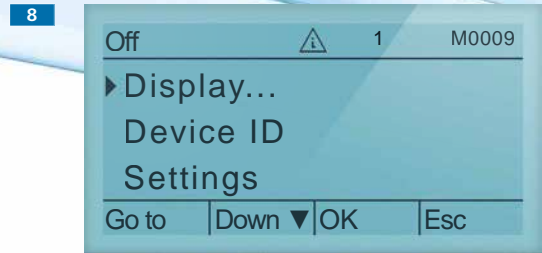
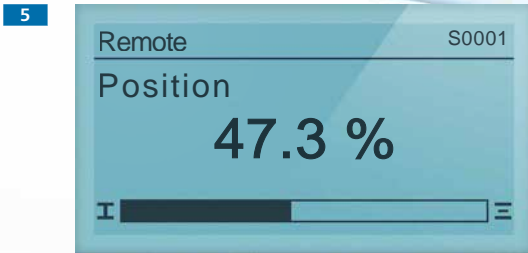

4 Operation and parameterisation

Depending on the selector switch position, the push buttons enable either electric actuator operation, status signals requests or menu navigation.

5 Displaying the valve position

The large display screen allows valve position indication that is even clearly recognisable from longer distances.

6 Displaying operation commands/setpoints

Operation commands and setpoints emitted from the DCS can be displayed.

7 Diagnostics/monitoring displays

Environmental conditions are continuously monitored during active operation. When exceeding permissible limits e.g. operating time, AC controls generate a warning signal.

8 Main menu

The main menu allows actuator data requests and operation parameter modifications.

9 Non-Intrusive setting

If the actuator is equipped with an electronic control unit (refer to page 63), the end positions and tripping torques can be set using the display without opening the actuator.

10 Failure

In case of failure, the backlight colour of the display changes to red. The cause for failure can be requested via the display.

Actuators are expected to offer long service life, high maintenance intervals and straightforward maintenance procedures. These factors are important in contributing to reducing plant operation costs.

Consequently, emphasis was laid on integrating advanced diagnostic abilities for development enhancements of AUMA devices.

Maintenance - when required

Running times, switching frequency, torque, ambient temperature - impacts which vary from actuator to actuator requiring individual maintenance schedules for each device. These factors are continually recorded and assessed in the following four maintenance status categories: O-rings, lubricant, reversing contactors, and mechanics. The maintenance requirements are shown on the display as bar chart. When reaching a limit, the actuator signals the respective maintenance requirement.

This function can be used to fulfil the lifetime requirements according to DIN 19704. As an alternative, defined intervals can be monitored by means of a maintenance schedule.

Out of specification - correct potential failure causes prior to occurrence

Plant operators receive anticipated information about potential problems. The signal indicates that the actuator is subjected to out of range operational conditions, for example excessive ambient temperatures which might lead to a failure in case of frequent and longer occurrence.

Plant Asset Management

If one of the two before mentioned signals are indicated, timely corrective actions can be introduced - the key to Plant Asset Management. Actions will be taken either by the service staff on site or by the AUMA service technicians, offering appropriate warranty on the basis of the repair or maintenance work.

AUMA service can propose maintenance agreements, and complete all required actions following signal indications.

RELIABILITY, SERVICE LIFE, MAINTENANCE - WITH TEST ENGINEERING FEATURES

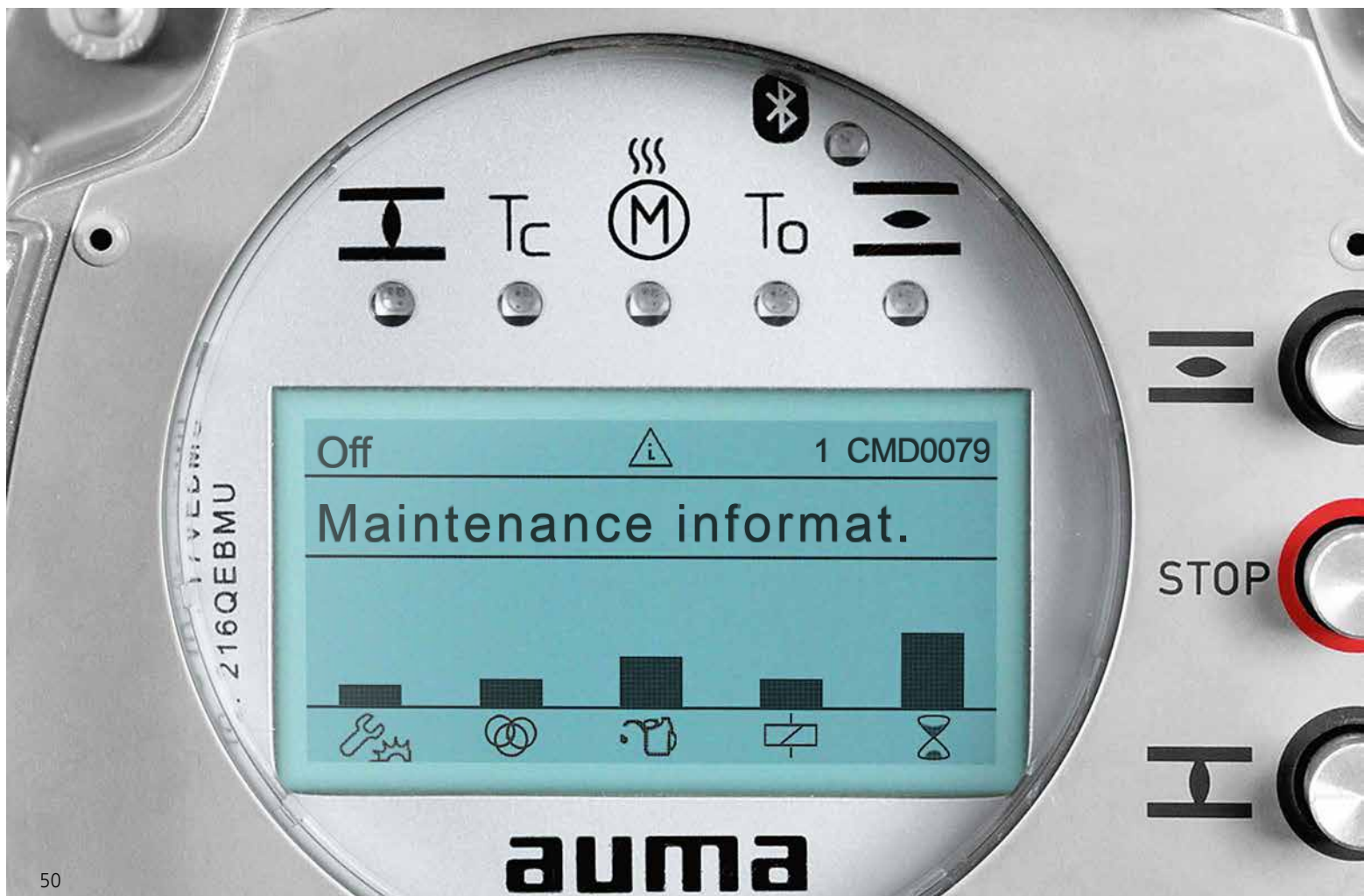

Time-stamped event report/ operating data logging

Setting procedures, switching procedures, warning signals, failures, and running times are recorded in the time-stamped event report. The event report is a distinct component of the diagnostic features of the AC.

Valve diagnostics

AC controls are capable of recording torque characteristics at different times. The comparison of data sets allows assessment of any changes in valve characteristics.

Assessment - easy to handle

NAMUR NE 107 with the easy and clear diagnostic classification supply valuable support for plant operators. Data relating to diagnostics can be requested via device display, via fieldbus or AUMA CDT (refer to page 54).

AUMA actuators with fieldbus interface also support standardised concepts for remote diagnostics from the control room (refer to page 45).

Diagnostic classification according to NAMUR NE 107

The objective of NAMUR NE 107 recommendation is to issue uniform and clear symbols and inform the operator about the device status.



Maintenance required

The actuator can still be controlled from the control room. The device must be inspected by a device specialist to avoid any unscheduled downtime.



Function check

Due to ongoing work on the actuator, the device cannot be controlled from the control room at that specific time.



Out of specification

Deviations from the permissible application conditions determined by the actuator itself through self-monitoring. The actuator can still be controlled from the control room.



Failure

Due to functional failures within the actuator or peripherals, the actuator might not be controlled from the control room.



AUMA CDT FOR AC CONTROLS - EASY COMMISSIONING

Any data can be requested and parameters changed via display and operating elements of the AC, without requiring further tools. This can be of crucial advantage in certain situations. Furthermore, AUMA CDT offers comfortable handling of device files.

This Commissioning and Diagnostic Tool (CDT) was specially developed for actuators with AC integral controls. Please refer to www.auma.com for free of charge download.

Connection to the actuator is established wireless via Bluetooth, it is password protected and encrypted.

Easy commissioning

The advantage of AUMA CDT is the clearly structured presentation of all device parameters. Tooltips are further valuable aids when defining the settings.

AUMA CDT allows to perform settings independently of the actuators, data saving, and later data transmission to the device. Actuator settings can be transferred to another device via AUMA CDT.

Actuator data can be archived in the AUMA CDT database.

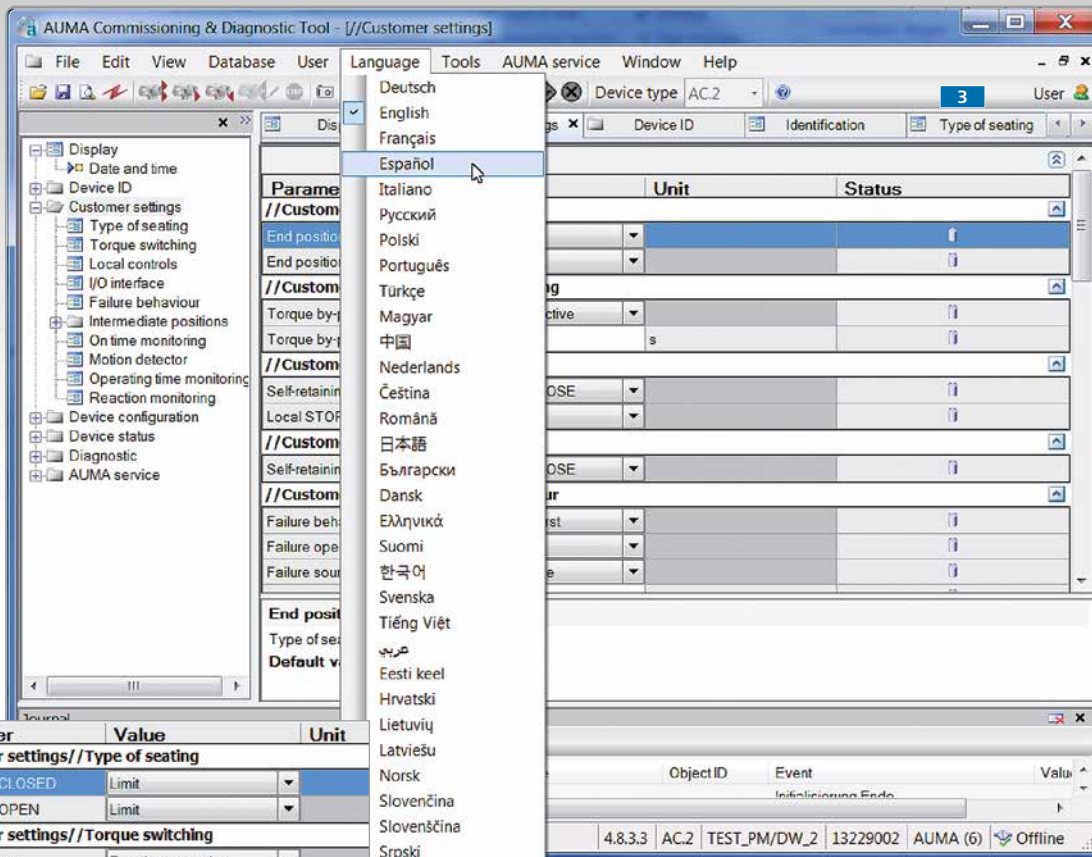

Parameter	Value	Unit
//Customer settings//Type of seating		
End position CLOSED	Limit	
End position OPEN	Limit	
//Customer settings//Torque switching		
Torque by-pass	Function not active	
Torque by pass duration	0,0	s
//Customer settings//Local controls		
Self-retaining LOCAL	OPEN and CLOSE	
Local STOP	Off	
//Customer settings//I/O interface		
Self-retaining Remote	OPEN and CLOSE	
//Customer settings//Failure behaviour		
Failure behaviour	Good signal first	
Failure operation	STOP	
Failure source	Active interface	
End position CLOSED		
Type of seating in end position CLOSED		
Default value: Limit		

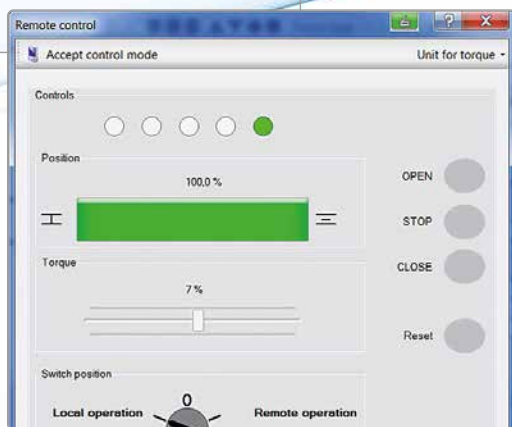

1 AUMA CDT - clear, multi-lingual, intuitive

CDT allows you to evaluate the precise condition before taking actions, the logic structure and parameter architecture are decisive. Text display is available in more than 30 languages. Completed and supported by tooltips 2. They provide brief explanations and the default values for the selected parameters.

3 Password protection

The various password protected user levels prevent unauthorised modifications of device settings.

4 Remote control

The actuator is remotely driven via AUMA CDT. All signals of indication lights and all status signals available via AC display are clearly visible. It is also possible to access from a laptop and immediately observe the reactions on the actuator status.



AUMA CDT FOR AC CONTROLS - DIAGNOSTIC DIALOGUE

Collecting operational data or recording characteristics is required to improve field device operation with regard to their lifetimes. A further requirement is the useful evaluation of the data obtained.

AUMA CDT offers a certain number of evaluation criteria supporting correct data analysis. Communication between AUMA Service and plant operators allow optimisation of device parameters or scheduling maintenance actions.

AUMA CDT - the information centre

Pertaining wiring diagram and matching data sheet - AUMA CDT downloads these documents directly from the AUMA server. Data records of actuators can be saved on the laptop and transmitted to AUMA service assessment.

AC controls are capable of recording characteristics; AUMA CDT offers optimum visualisation via Live View. This supports device behaviour evaluation during service. AUMA CDT is equipped with functions for device history assessment in order to graphically process the chronologically saved events within the event report.

AUMA CDT supplies a total view on the actuators, the ideal prerequisite to correctly assess the actuator status and the immediate peripheral equipment.

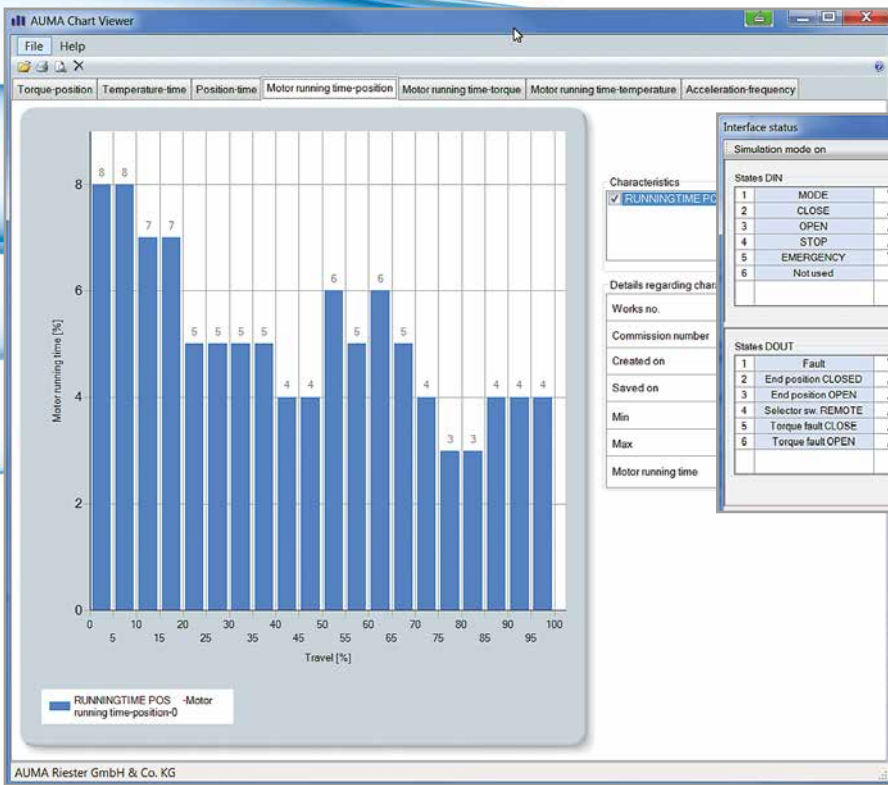

1

State	Value
States AN 1 - Setpoint position	0.0 mA
States AN 2 - Input AIN 2	0.0 mA
States ADUT 1 - Actual position	20.0 mA
States ADUT 2 - Torque	10.5 mA

2



3

AUMA CDT as fieldbus master

Actuator function failure can be caused by faulty communication with the control station. For parallel communication, signal paths between control room and actuator can be verified by means of a measuring device. Functional tests are also recommended for fieldbus applications.

AUMA CDT can be used as temporary fieldbus master. It can be used to verify whether the actuator correctly receives, processes, and responds to fieldbus telegrams. If this is the case, the failure is not caused by the actuator.

Further use of AUMA CDT fieldbus master: The actuator can even be commissioned if communication to the DCS is not established or not possible, e.g. in an assembly workshop.

Examples of analysis tools

- > **1** The motor running time across valve position indicates whether the valve position is within expected range across the elapsed time period.
- > **2** The interface status window visualises which signals are present at the interface to the DCS.

3 AUMA Assistant App

You may also quickly and easily access the device documentation via the AUMA Assistant App. When scanning the Data Matrix code on the name plate via smartphone or tablet PC, the app allows request and download of operation instructions, wiring diagram, technical data sheet, and inspection certificate pertaining to an actuator from the AUMA server to your mobile device.

Your scanned actuators are managed in a clear serial number list. If required, you may call support from our Service directly on the basis of this list.

The AUMA Assistant App is available for free download: For Android-based devices in the Google Play Store, for Apple devices with iOS operating system in the Apple store. The QR code below leads you directly to the App. The respectively required version is automatically selected.





AC

SA





AM



SQ



SA multi-turn actuator and SQ part-turn actuator

The basic actuator consists of the following components: motor, worm gearing, control unit, handwheel for emergency operation, electrical connection and valve attachment.

For actuators with this type of basic equipment, operation commands and feedback signals can be processed by means of external controls provided with switchgear and the pertaining logic.

Typically, AUMA actuators are supplied with AM or AC integral controls. Due to the modular design principle, the controls are connected to the actuator via a simple plug/socket connection.

Differences between SA and SQ actuators

The output shaft **1a** of SA multi-turn actuators is a hollow shaft to allow the stem to pass through the actuator should the valve be equipped with a rising valve stem.

SQ part-turn actuators are equipped with mechanical end stops **1b** for swing angle limitation to make sure that valve end positions can be precisely approached during manual operation. Part-turn actuators are available with various swing angle ranges.

2 Motor

Use of 3-phase AC, 1-phase AC and DC motors with high starting torques - specifically developed for valve automation. Thermal protection is ensured by thermoswitches or PTC thermistors.

A dog coupling for torque transmission and an internal motor plug/socket connector allow for fast replacement. For further information, please refer to page 71.

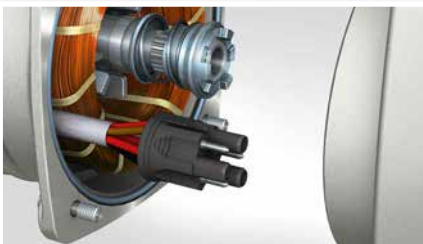

Control unit

Determining the valve position and setting the valve end positions/torque monitoring to protect the valve against overload. Depending on customer specifications, a control unit is installed either as electromechanical or electronic version.

3a Control unit - electromechanical version

Travel and torque are mechanically sensed; switches are operated when reaching the tripping points. The tripping points for both end positions and the tripping torques for both directions are mechanically set.

As an option, the valve position can be transmitted as continuous signal to the control room.

The electromechanical control unit is needed if the actuator is supplied without integral controls. The unit can be combined with both AUMA controls types: AM and AC.

3b Control unit - electronic version

High-resolution magnetic transmitters convert valve position and applied torque into electronic signals. End position and torque settings during commissioning are performed at AC controls without opening the enclosure. Valve position and torque are transmitted as continuous signal.

The electronic control unit comprises sensors to record the torque change, vibration and device temperature. AC controls time stamp and analyse this data, serving as basis for preventive maintenance schedules (please also refer to page 50).

For further information, please refer to pages 63 and 69.

4 Valve attachment

The mechanical interface to the valve is standardised. This ensures long-term exchangeability and compatibility.

For multi-turn actuators, flange dimensions and output drive types comply with EN ISO 5210 or DIN 3210. For part-turn actuators, connection to the valve has to comply with EN ISO 5211.

All output drive types are available in a multitude of variants.



AC

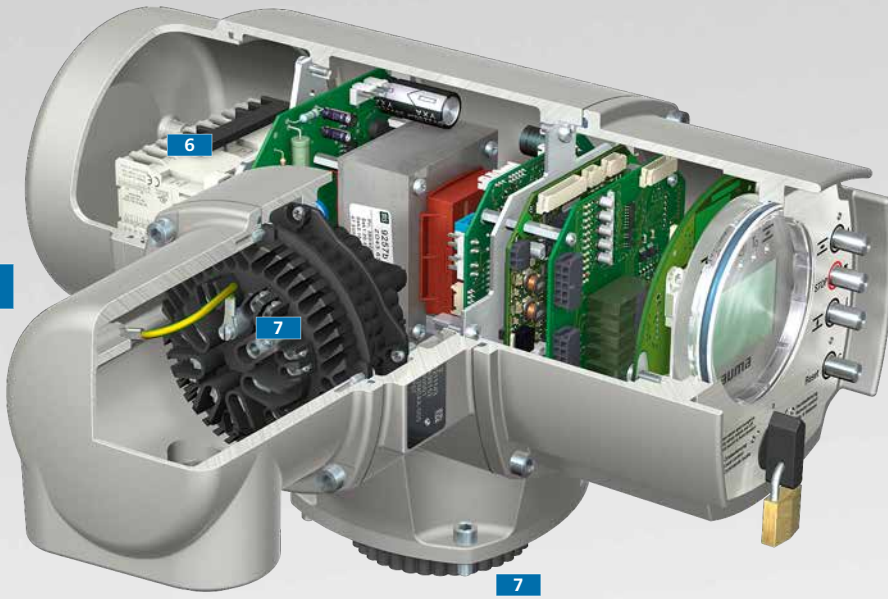

AM



SA

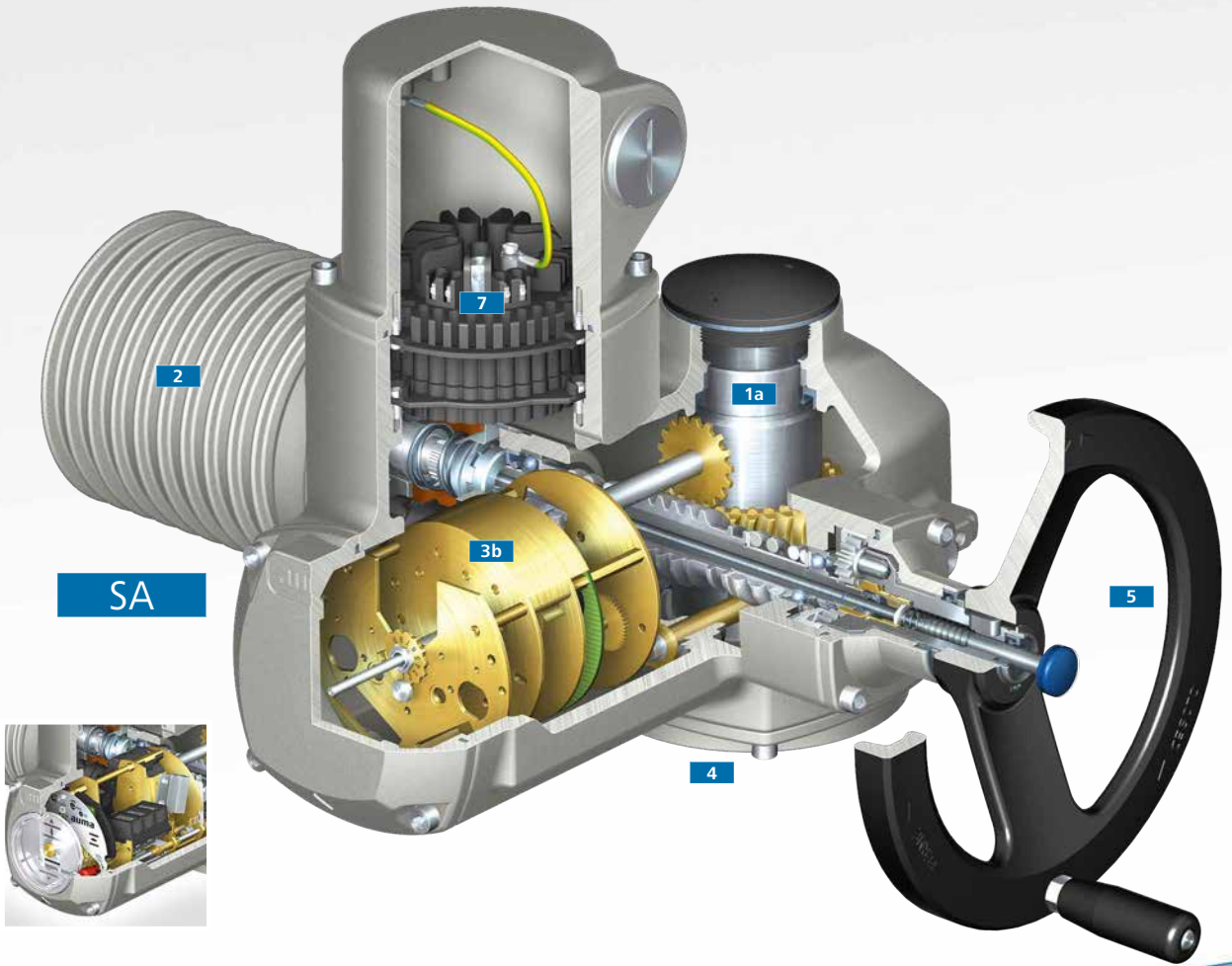

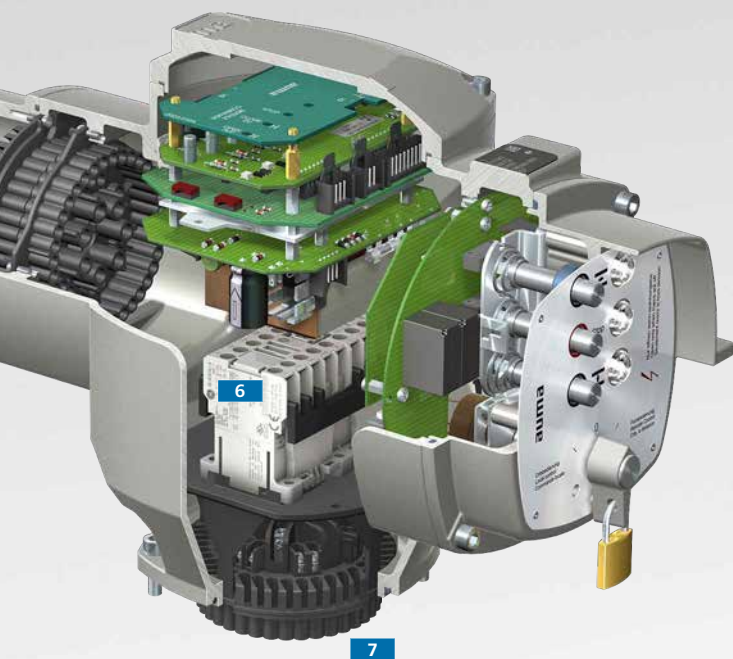

5 Handwheel

Handwheel for emergency operation in the event of power failure. Handwheel activation and handwheel operation require minimal effort. The self-locking effect is maintained even during manual operation.

Options:

- > Microswitches signal activation of manual operation to controls
- > Locking device to protect against unauthorised operation
- > Handwheel extension
- > Adapter for power tool emergency operation
- > Chain wheel with remote switch-over

Please also refer to page 34.

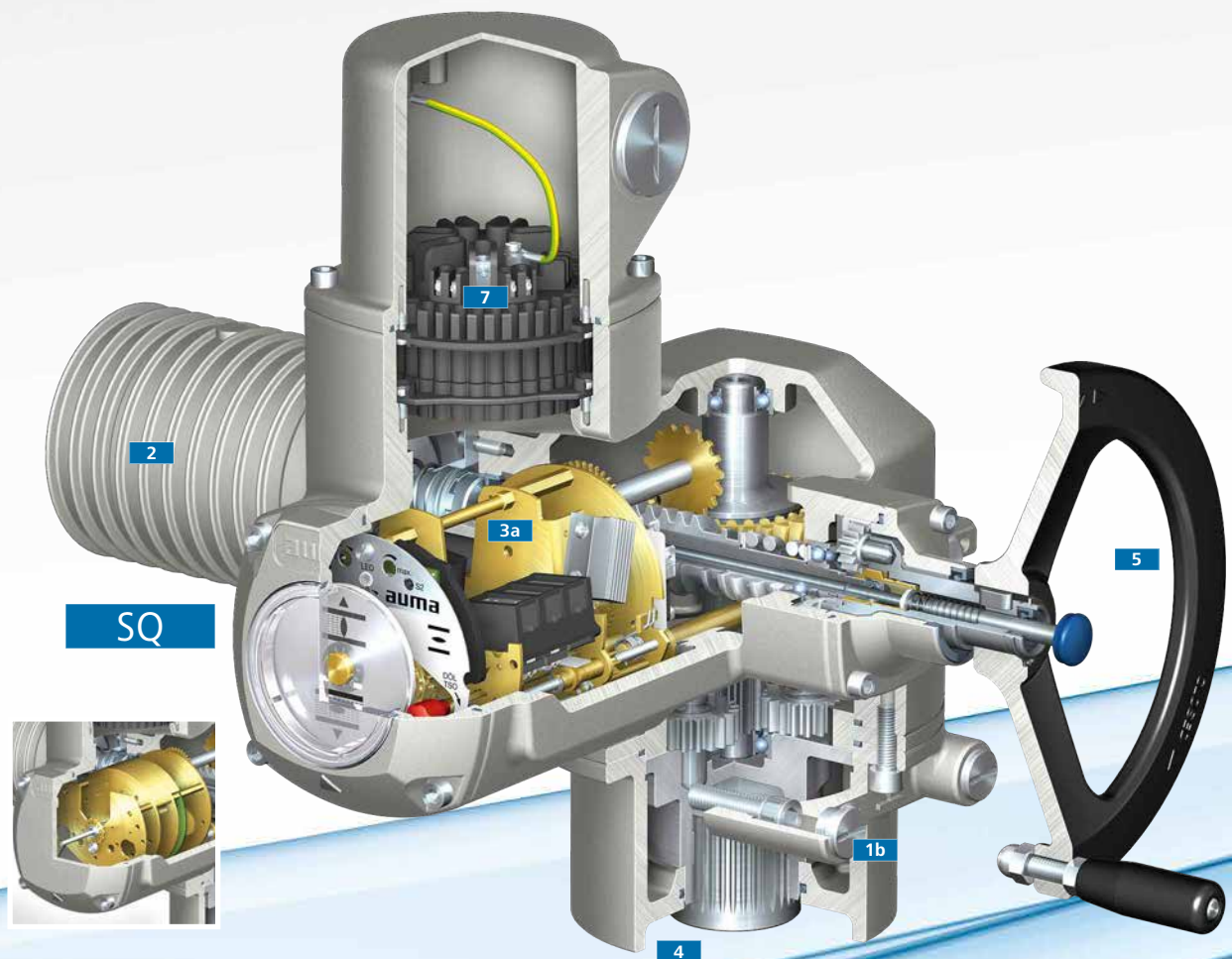



Integral actuator controls

Actuators equipped with AM or AC integral controls can be electrically driven via local controls as soon as the electrical power supply is connected. Actuator controls contain switchgear, power supply units and interfaces to the DCS. They can process operation commands and feedback signals from the actuator.

Electrical connection between integral controls and the actuator is made by using a quick release plug/socket connector.

For further information on controls, please refer to pages 40 and 73 and respectively the subsequent pages.

AM

Controls comprising simple logic to process limit and torque signals as well as the control commands OPEN, STOP, CLOSE. Three indication lights at local controls indicate the actuator status.

AC

Microprocessor based controls with comprehensive functionality and configurable interface. A graphic display indicates actuator status in more than 30 languages. When combined with the electronic control unit **3b**, all settings can be performed without opening the housing. Programming via menu navigation is made directly at the device or wireless via Bluetooth using the AUMA CDT.

AC controls are ideal for challenging actuator integration into complex control systems. Supporting Plant Asset Management.

AC controls are equipped with a further sensor for continuous temperature measurement within the framework of the preventive maintenance schedule.



6 Switchgear

In standard version, reversing contactors are used to switch the motor on or off. If modulating actuators are expected to perform a high number of starts, we recommend using thyristor units not subject to wear (also refer to page 73).

7 Plug-in electrical connection

The plug-in electrical connection with 50 pole AUMA plug/socket connector is crucial to modular design. The connector is a separate unit.

Different connector types are available and compatible throughout all type ranges and used for actuators with or without integral controls.

During maintenance work, the wiring remains undisturbed; electrical connections can be quickly separated and reconnected. This reduces downtimes and avoids wiring faults when reconnecting.

This power supply interface allows easy and fast actuator exchange.

AC controls are equipped with an easily accessible fuse holder within the electrical connection containing the short-circuit fuses for the transformer's primary windings.



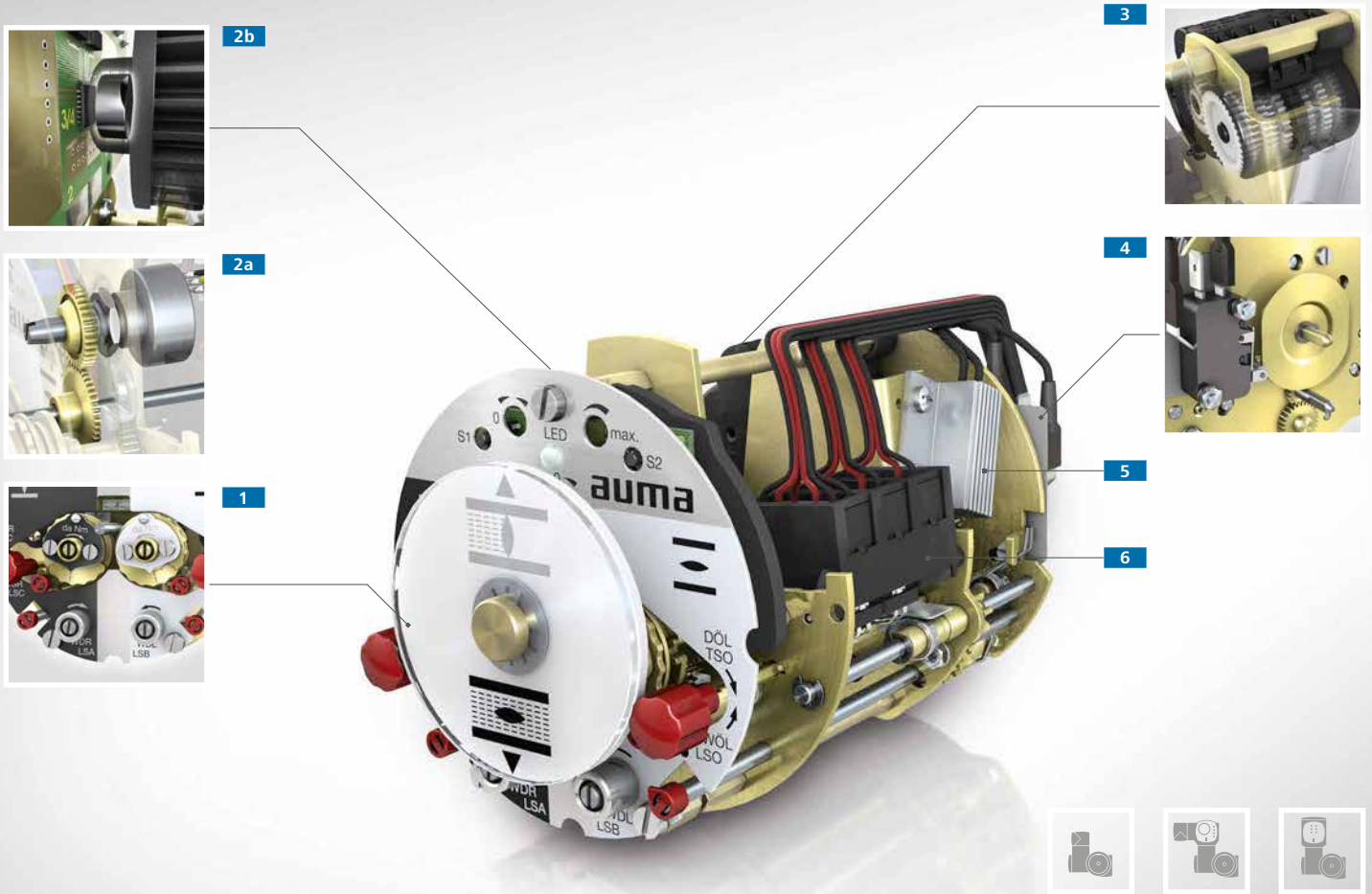

ELECTROMECHANICAL CONTROL UNIT

The control unit contains a sensor system for automatic actuator switch-off once the end position is reached. For this version, end position and torque recording are on mechanical basis.

1 Setting limit and torque switches

After removal of the housing cover and the mechanical position indicator, all setting elements are freely accessible (also refer to page 69).

2 Remote position transmitter

Valve position can be signalled to the DCS via the potentiometer voltage signal **2a** or a 4 – 20 mA signal (EWG, RWG) (please also refer to page 70). Valve position detection by the EWG **2b** is made contactless and consequently avoids wear.

3 Reduction gearing

The reduction gearing is required to reduce the valve stroke to the recording range of the remote position transmitter and the mechanical position indicator.

4 Blinker transmitter for running indication

Throughout travel, the segment washer operates the blinker switch (please also refer to page 69).

5 Heater

The heater minimises condensation within the switch compartment (also refer to page 72).

6 Limit and torque switches

The respective contact is operated when reaching an end position or exceeding a tripping torque.

In the basic version, one limit switch each is available for end positions OPEN and CLOSED and one torque switch for directions OPEN and CLOSE (also refer to page 69). For switching two different potentials, tandem switches with two galvanically isolated compartments can be integrated.

Intermediate position switches

As an option, intermediate switches can be integrated for each direction with the objective to set one further switching point for each direction, as required.

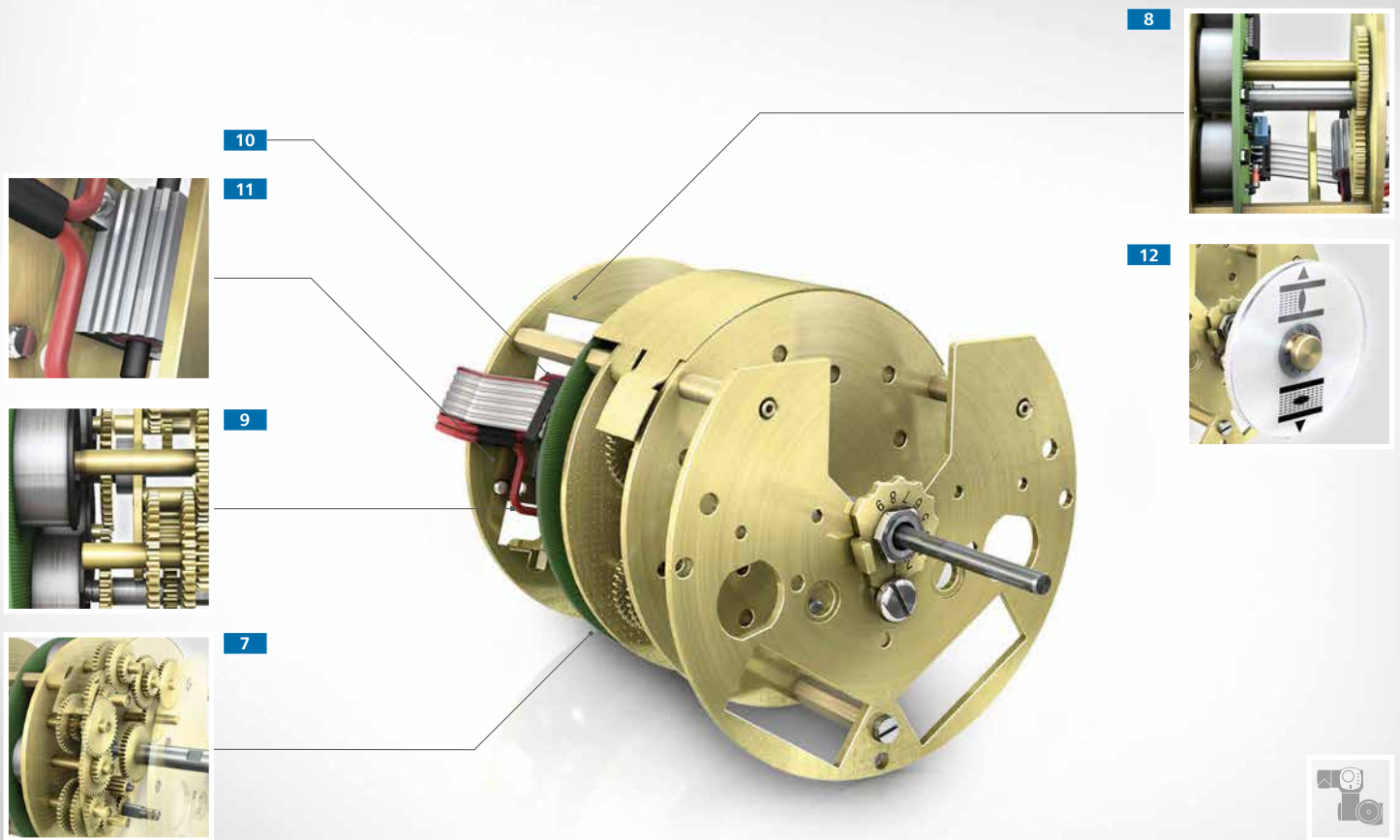

ELECTRONIC CONTROL UNIT

Non-Intrusive - without requiring any tools or opening the device - all settings are made externally if equipped with an electronic control unit (MWG) and AC integral controls.

7 Absolute encoder - Limit

Positions of magnets in the four gear stages correspond to the valve position. This type of limit sensing identifies valve position changes even in case of power failure. Consequently, battery backup is not required.

8 Absolute encoder - Torque

Magnet position corresponds to the torque applied at valve flange.

9 Electronic sensing of limit and torque

Hall sensors permanently sense magnet positions for limit and torque recording within the absolute encoders. A continuous limit and torque signal is generated by the integral electronics. The magnetic functional principle is robust and resistant against electromagnetic interference.

End position and torque settings are saved in the electronic control unit. These settings are still available and valid even when replacing AC controls.

10 Vibration and temperature sensors

The electronic board houses a vibration and a temperature sensor for continuous temperature measurement. Data is evaluated using internal diagnostic functions.

11 Heater

The heater minimises condensation within the switch compartment (also refer to page 72).

12 Mechanical position indicator

Optional position indication disc identifies valve position even without power supply during manual actuator operation.

Switches for SIL version (without illustration)

If the electronic control unit is used in an actuator in SIL version (refer to page 38), additional limit switches are installed in the control unit.

On demand of the safety function, the switches trip when reaching the end position and the motor is switched off.



The technical data shown below is an extract of available data sheets. They provide a rough outline on the performance of AUMA devices. Please refer to the Internet for further data sheets or contact us to receive printed or digital copies.

APPLICATIONS FOR HYDRAULIC STEEL STRUCTURES (HSS)

Wear and loads on steel structures for water resources differ depending on the application. The definition of standard applications was the basis for following actuator dimensioning classification.

	HSS 1	HSS 2	HSS 3
Desired lifetime	35 years	35 years	35 years
Load of lock/ number of locking cycles	low	medium	high
Application profile for sluice gates	Tourist use in summer	Commercial use during ice-free months 12 h/d	Commercial use 24 h/d throughout the year
Application profile for weirs	Retention of floodwater	Roughly maintaining the level	Retention of sluice gates

SA MULTI-TURN ACTUATORS

The following data is valid for actuators with 3-phase AC motors operated in duty type S2 - 15 min.

For detailed information, restrictions for actuators with high output speeds as well as data on other motor types and types of duty, refer to separate technical and electrical data sheets.

Type	Output speeds at 50 Hz [rpm]	Setting range for tripping torque ¹ [Nm]	Run torque [Nm] for application			Valve output mounting flange	
			HSS 1	HSS 2	HSS 3	EN ISO 5210	DIN 3210
SA 07.2	4; 5,6; 8; 11; 16; 22; 32; 45; 63; 90; 125	10 – 30	12	8	6	F07 or F10	G0
	180	10 – 25					
SA 07.6	4; 5,6; 8; 11; 16; 22; 32; 45; 63; 90; 125	20 – 60	25	15	12	F07 or F10	G0
	180	20 – 50					
SA 10.2	4; 5,6; 8; 11; 16; 22; 32; 45; 63; 90; 125	40 – 120	50	30	24	F10	G0
	180	40 – 100					
SA 14.2	4; 5,6; 8; 11; 16; 22; 32; 45; 63; 90; 125	100 – 250	100	65	50	F14	G1/2
	180	100 – 200					
SA 14.6	4; 5,6; 8; 11; 16; 22; 32; 45; 63; 90; 125	200 – 500	175	125	100	F14	G1/2
	180	200 – 400					
SA 16.2	4; 5,6; 8; 11; 16; 22; 32; 45; 63; 90	400 – 1,000	350	250	200	F16	G3
	125; 180	400 – 800					
SA 25.1	4; 5,6; 8; 11; 16; 22; 32; 45; 63; 90	630 – 2,000	700	500	400	F25	G4
SA 30.1	4; 5,6; 8; 11; 16; 22; 32; 45; 90	1,250 – 4,000	1,400	1,000	800	F30	G5
SA 35.1	4; 5,6; 8; 11; 16; 22; 32; 45	2,500 – 8,000	2,800	1,750	1,400	F35	G6
SA 40.1	4; 5,6; 8; 11; 16; 22; 32; 45	5,000 – 16,000	5,600	3,500	2,800	F40	G7

Lifetime

Type	Number of turns at output drive in millions ²		
	HSS 1	HSS 2	HSS 3
SA 07.2 – SA 14.2	1.2	5.0	10.0
SA 14.6 – SA 16.2	0.9	4.0	8.0
SA 25.1 – SA 30.1	0.6	2.5	5.0
SA 35.1 – SA 40.1	0.3	1.0	2.0

The curve on the right shows the lifetime depending on the run torque for an SA 07.6 multi-turn actuator. The lifetime values can be interpolated for deviating run torques. Please contact AUMA for correct sizing.



¹ resistance to fracture up to more than 2 times the maximum value.

² at load with run torque and even load distribution in directions OPEN and CLOSE. For higher lifetime requirements, reduce the torques (run torques) accordingly. For detailed information, refer to the separate technical data sheets.



SAV MULTI-TURN ACTUATORS WITH VARIABLE MOTOR SPEED

The following data is valid for actuators with 3-phase and 1-phase AC motors operated in duty type S2 - 15 min. For detailed information, restrictions depending on operating temperature or operating voltage as well as data on other types of duty, refer to separate technical and electrical data sheets.

Type	Output speed [rpm]	Setting range for tripping torque ¹ [Nm]	Run torque [Nm] for application			Valve mounting flange		Available mains voltage/mains frequency			
			HSS 1	HSS 2	HSS 3	EN ISO 5210	DIN 3210	1-phase AC		3-phase AC	
								110 V – 120 V 50 – 60 Hz	220 V – 240 V 50 – 60 Hz	220 V – 240 V 50 – 60 Hz	380 V – 480 V 50 – 60 Hz
SAV 07.2	6 – 60	10 – 30	12	8	6	F07 or F10	G0	■	■	■	■
	12 – 120							■	■	■	■
	24 – 240	10 – 25						■	■	■	■
SAV 07.6	6 – 60	20 – 60	25	15	12	F07 or F10	G0	■	■	■	■
	12 – 120							■	■	■	■
	24 – 240	20 – 50						■	■	■	■
SAV 10.2	6 – 60	40 – 120	50	30	24	F10	G0	●	■	■	■
	12 – 120							–	■	■	■
	24 – 240	40 – 100						–	■	■	■
SAV 14.2	6 – 60	100 – 250	100	65	50	F14	G1/2	–	■	■	■
	12 – 120							–	●	●	■
	24 – 240	100 – 200						–	–	▲	■
SAV 14.6	6 – 60	200 – 500	175	125	100	F14	G1/2	–	–	▲	■
	12 – 120							–	–	–	●
	24 – 240	200 – 400						–	–	–	●
SAV 16.2	6 – 60	400 – 1,000	350	250	200	F16	G3	–	–	–	●

Symbol	Explanation
■	Without restriction to +70 °C ambient temperature
●	For ambient temperatures exceeding +40 °C, restrictions may occur for max. permissible run torque, mode of operation and running time. Detailed information on request
▲	Special sizing on request

Lifetime

Type	Number of turns at output drive in millions ²		
	HSS 1	HSS 2	HSS 3
SAV 07.2 – SAV 14.2	1.2	5.0	10.0
SAV 14.6 – SAV 16.2	0.9	4.0	8.0

Technical data to the following actuators are available on request: SAR, SARV, SQ and SQR.

¹ resistance to fracture up to more than 2 times the maximum value.

² at load with run torque and even load distribution in directions OPEN and CLOSE. For higher lifetime requirements, reduce the torques (run torques) accordingly. For detailed information, refer to the separate technical data sheets.



SA MULTI-TURN ACTUATORS WITH GK MULTI-TURN GEARBOXES

GK bevel gearboxes in combination with SA multi-turn actuators act as multi-turn actuators with higher output torques. Drive shaft and output shaft are perpendicular. Thus, this combination is particularly appropriate for implementing special automation solutions. These include among others particular mounting positions or simultaneous operation of two valve stems using two GK gearboxes and a central actuator.



The following indications are valid for type of duty S2 - 15 min and serve the purpose of a rough outline. Separate data sheets are available for GK gearboxes comprising detailed information.

Type	Reduction ratios	Maximum torque Nm	Run torque [Nm] for application			Lifetime [Number of turns at output drive in millions] ² for the application			Valve mounting flange	
			HSS 1	HSS 2	HSS 3	HSS 1	HSS 2	HSS 3	EN ISO 5210	DIN 3210
GK 10.2	1 : 1 2 : 1	120	60	30	24	1.2	5	10	F10	G0
GK 14.2	2 : 1 2.8 : 1	250	120	65	50	1.2	5	10	F14	G1/2
GK 14.6	2.8 : 1 4 : 1	500	175	125	100	0.9	4	8	F14	G1/2
GK 16.2	4 : 1 5.6 : 1	1,000	350	250	200	0.9	4	8	F16	G3
GK 25.2	5.6 : 1 8 : 1	2,000	700	500	400	0.6	2.5	5	F25	G4
GK 30.2	8 : 1 11 : 1	4,000	1,400	1,000	800	0.6	2.5	5	F30	G5
GK 35.2	11 : 1 16 : 1	8,000	2,800	1,750	1,400	0.3	1	2	F35	G6
GK 40.2	16 : 1 22 : 1	16,000	5,600	3,500	2,800	0.3	1	2	F40	G7 ¹

Combination facilities between GK multi-turn gearboxes and multi-turn actuators

Gearbox type	Reduction ratio	Mounting flange for actuator	Suitable AUMA multi-turn actuator
GK 10.2	1 : 1 2 : 1	F10/F14 F10	SA 14.2 SA 10.2
GK 14.2	2 : 1 2.8 : 1	F10/F14 F10	SA 14.2 SA 10.2
GK 14.6	2.8 : 1 4 : 1	F14 F10/F14	SA 14.2 SA 14.2
GK 16.2	4 : 1 5.6 : 1	F14 F14	SA 14.6 SA 14.2
GK 25.2	5.6 : 1 8 : 1	F14 F14	SA 14.6 SA 14.6
GK 30.2	8 : 1 11 : 1	F14/F16 F14	SA 16.2 SA 14.6
GK 35.2	11 : 1 16 : 1	F16 F14/F16	SA 16.2 SA 16.2
GK 40.2	16 : 1 22 : 1	F16/F25 F16	SA 25.1 SA 16.2

¹ without spigot

² at load with run torque and even load distribution in directions OPEN and CLOSE. For higher lifetime requirements, reduce the torques (run torques) accordingly. For detailed information, refer to the separate technical data sheets.



SA MULTI-TURN ACTUATORS WITH GHT MULTI-TURN GEARBOXES

GHT worm gearboxes in combination with SA multi-turn actuators act as multi-turn actuators with high output torques. The torque range increases nearly fourfold when combining GHT gearboxes with SAEx actuators. This type of torque requirements occurs e.g. for large gate valves, weir penstocks or dampers.



The following indications are valid for type of duty S2 - 15 min and serve the purpose of a rough outline. Please refer to the separate data sheets for more detailed information.

Type	Reduction ratios	Suitable AUMA multi-turn actuator	Run torque [Nm] at GHT output drive for the application			Lifetime SA + GHT [Number of turns at output drive] ¹ for the application			Valve mounting flange
			HSS 1	HSS 2	HSS 3	HSS 1	HSS 2	HSS 3	
GHT 320.3	10 : 1	SA 30.1	11,200	8,800	6,400	60,000	75,000	75,000	F48
	15.5 : 1	SA 25.1	8,680	6,820	4,60	39,000	75,000	75,000	
	20 : 1	SA 25.1	11,200	8,800	6,400	30,000	75,000	75,000	
GHT 500.3	10.25 : 1	SA 35.1	22,960	16,400	11,480	30,000	75,000	75,000	F60
	15.5 : 1	SA 30.1	16,800	13,200	9,600	39,000	75,000	75,000	
	20 : 1	SA 30.1	22,960	18,040	13,120	30,000	75,000	75,000	
GHT 800.3	10.25 : 1	SA 35.1	26,880	19,200	13,440	30,000	75,000	75,000	F60
	20 : 1	SA 35.1	33,600	24,000	16,800	15,000	50,000	75,000	
GHT 1200.3	10.25 : 1	SA 40.1	45,920	32,800	22,960	30,000	75,000	75,000	F60
	20 : 1	SA 35.1	45,920	32,800	22,960	15,000	50,000	75,000	

¹ at load with run torque and even load distribution in directions OPEN and CLOSE. For higher lifetime requirements, reduce the torques (run torques) accordingly. For detailed information, refer to the separate technical data sheets.



SA MULTI-TURN ACTUATORS WITH GS WORM GEARBOXES, WORM WHEEL MADE OF BRONZE

In civil engineering constructions for water applications, multi-turn GS worm gearboxes in combination with SA multi-turn actuators are typically used. Due to long running times and large strokes, AUMA recommends the worm wheel version made of bronze.

The following indications are valid for part-turn gearboxes in multi-turn version with worm wheel made of bronze for type of duty S2 - 15 min and serve the purpose of a rough outline. Please refer to the separate data sheets for more detailed information.



Type	Primary reduction gearing	Reduction ratio	Maximum torque	Run torque	Input torque at maximum torque	Input torque at run torque	Output mounting flange
			Nm	Nm	Nm	Nm	EN ISO 5210
GS .100.3	–	52:1	2,000	1,000	99	50	F14/F16
	VZ 2.3	126:1			45	23	
	VZ 3.3	160:1			36	18	
	VZ 4.3	208:1			26	13	
GS .125.3	–	52:1	4,000	2,000	192	96	F16/F25
	VZ 2.3	126:1			88	44	
	VZ 3.3	160:1			69	35	
	VZ 4.3	208:1			52	26	
GS .160.3	–	54:1	8,000	4,000	353	176	F25/F30
	GZ 4:1	218:1			97	48	
	GZ 8:1	442:1			48	24	
GS .200.3	–	53:1	16,000	8,000	718	359	F30/F35
	GZ 4:1	214:1			197	98	
	GZ 8:1	434:1			97	48	
	GZ 16:1	864:1			52	26	
GS .250.3	–	52:1	32,000	16,000	1,462	731	F35/F40
	GZ 4:1	210:1			401	200	
	GZ 8:1	411:1			205	103	
	GZ 16:1	848:1			105	53	
GS .315	–	53:1	63,000	32,000	2 423	1 231	F40
	GZ 30.1 8:1	424:1			354	180	
	GZ 30.1 16:1	848:1			177	90	
	GZ 30.1 32:1	1,696:1			88	45	
GS .400	–	54:1	125,000	63,000	4,717	3,377	F48
	GZ 35.1 8:1	432:1			691	348	
	GZ 35.1 16:1	864:1			344	174	
	GZ 35.1 32:1	1,728:1			172	87	
GS .500	–	52:1	250,000	125,000	9,804	4,902	F60
	GZ 40.1 16:1	832:1			714	357	
	GZ 40.1 32:1	1,664:1			358	179	
	GZ 40.1/GZ 16.1 64:1	3,328:1			203	101	
GS .630.3	–	52:1	480,000	240,000	24,242	12,121	F60 AUMA
	GZ 4:1	210:1			6,676	3,338	
	GZ 8:1	425:1			3,299	1,649	
	GZ 16:1	848:1			1,838	919	
	GZ 32:1	1,718:1			908	454	
	GZ 64:1	3,429:1			505	252	
	GZ 133:1	6,939:1			249	125	

Lifetime

Type	Number of turns at output drive ¹
GS 100.3 – GS 200.3	15,000
GS .250.3	10,000
GS .315	4,700
GS 400 – GS 500	2,500
GS .630.3	1,500

¹ at load with run torque and even load distribution in directions OPEN and CLOSE. For higher lifetime requirements, reduce the torques (run torques) accordingly. For detailed information, refer to the separate technical data sheets.

Note: max. 10 turns at output drive/stroke, followed by cooling down phase



CONTROL UNIT

Setting ranges of limit switching for SA and SAR

For multi-turn actuators, the control unit records the number of turns per stroke. There are two versions for various ranges.

	Turns per stroke	
	Electromechanical control unit	Electronic control unit
Standard	2 – 500	1 – 500
Option	2 – 8,000	10 – 5,000

ELECTRONIC CONTROL UNIT

When using the electronic control unit, reaching an end position, valve position, torque, temperature within the unit, and vibration are recorded in digital form and transmitted to AC integral controls. AC controls internally process all signals and provide respective indications via the respective communication interface.

Conversion of mechanical parameters into electronic signals is contactless and therefore reduces wear. The electronic control unit is prerequisite for non-intrusive setting of the actuator.

ELECTROMECHANICAL CONTROL UNIT

Binary and analogue signals of the electromechanical control unit are internally processed if AM or AC integral controls are supplied. For actuators without integral controls, signals are transmitted via electrical connection. In this case, the following technical data for switches and remote position transmitters is required.

Limit/torque switches

Versions		
	Application/description	Type of contact
Single switches	Standard	One NC contact and one NO contact
Tandem switches (option)	For switching two distinct potentials. The switches have two compartments with galvanically isolated switches in a common sealed housing. The two switches are operated together; one switch is leading and should be used for signalisation.	Two NC contacts and two NO contacts
Triple switches (option)	For switching three distinct potentials. This version consists of one single and one tandem switch.	Three NC contacts and three NO contacts

Rated power	
Silver plated contacts	
U min.	24 V AC/DC
U max.	250 V AC/DC
I min.	20 mA
I max. AC current	5 A at 250 V (resistive load) 3 A at 250 V (inductive load, $\cos \varphi = 0.6$)
I max. DC current	0.4 A at 250 V (resistive load) 0.03 A at 250 V (inductive load, $L/R = 3 \mu s$) 7 A at 30 V (resistive load) 5 A at 30 V (inductive load, $L/R = 3 \mu s$)

Rated power	
Gold-plated contacts (option)	
U min.	5 V
U max.	50 V
I min.	4 mA
I max.	400 mA

Switches - other features

Operation	Lever
Contact element	Snap-action contact (double break)

Blinker transmitter for running indication

Rated power	
Silver plated contacts	
U min.	10 V AC/DC
U max.	250 V AC/DC
I max. AC current	3 A at 250 V (resistive load) 2 A at 250 V (inductive load, $\cos \varphi \approx 0.8$)
I max. DC current	0.25 A at 250 V (resistive load)

Blinker transmitter - other features

Operation	Segment washer
Contact element	Snap action contact
Type of contact	Change-over contact

SA MULTI-TURN ACTUATORS – DETAILS

ELECTROMECHANICAL CONTROL UNIT (CONT'D)

Remote position transmitter

Precision potentiometer for OPEN-CLOSE duty		
	Single	Tandem
Linearity	≤ 1 %	
Power	1.5 W	
Resistance (standard)	0.2 kΩ	0,2/0,2 kΩ
Resistance (option) further variants on request	0.1 kΩ, 0.5 kΩ, 1.0 kΩ, 2.0 kΩ, 5.0 kΩ	0.5/0.5 kΩ, 1.0/1.0 kΩ, 5.0/5.0 kΩ, 0.1/5.0 kΩ, 0.2/5.0 kΩ, 1.0/5.0 kΩ
Max. wiper current	30 mA	
Lifetime	100,000 cycles	

Precision film potentiometer for modulating duty		
	Single	Tandem
Linearity	≤ 1 %	
Power	0.5 W	
Resistance further variants on request	1.0 kΩ or 5.0kΩ	1.0/5.0 kΩ, 1.0/1.0 kΩ or 5.0/5.0 kΩ
Max. wiper current	0.1 mA	
Lifetime	5m cycles	
Max. ambient temperature ¹	+90 °C	

Electronic position transmitter EWG		
	2-wire	3-wire/4-wire
Output signal	4 – 20 mA	0/4 – 20 mA
Power supply	24 V DC (18 – 32 V)	
Max. ambient temperature ¹	+80 °C (standard)/+90 °C (option)	

RWG electronic remote position transmitter		
	2-wire	3-wire/4-wire
Output signal	4 – 20 mA	0/4 – 20 mA
Power supply	14 V DC + (I x R _p), max. 30 V	24 V DC (18 – 32 V)

HANDWHEEL ACTIVATION

Rated power of microswitch to signal handwheel activation	
Silver plated contacts	
U min.	12 V DC
U max.	250 V AC
I max. AC current	3 A at 250 V (inductive load, cos phi = 0.8)
I max. DC current	3 A at 12 V (resistive load)

Microswitches for signalling handwheel activation – other features	
Operation	Lever
Contact element	Snap action contact
Type of contact	Change-over contact
Max. ambient temperature ¹	+80 °C

VIBRATION RESISTANCE

According to EN 60068-2-6.

Actuators withstand vibration during start-up or in case of plant failures up to 2 g, within the frequency range from 10 to 200 Hz. However, a fatigue strength may not be derived from this.

This data is valid for SA and SQ actuators without integral controls with AUMA plug/socket connector (S) but not in combination with gearboxes.

Complying to the conditions above, the applicable load limit for actuators with AM or AC integral controls amounts to 1 g.

MOUNTING POSITION

AUMA actuators, even when equipped with integral controls, can be operated without restriction in any mounting position.

NOISE LEVEL

The noise level originated by the actuator remains below the noise level of 72 dB (A).



SUPPLY VOLTAGES/MAINS FREQUENCIES

Hereafter, please find the standard supply voltages (other voltages upon request). Some actuator versions or sizes are not available with the stipulated motor types or voltages/frequencies. For detailed information, please refer to the separate electrical data sheets.

Standard voltages

3-phase AC current Voltages/frequencies											
Volt	220	230	380	380	400	400	415	440	460	480	500
Hz	60	50	50	60	50	60	50	60	60	60	50

Special voltages

3-phase AC current Voltages/frequencies							
Volt	220	440	525	575	600	660	690
Hz	50	50	50	60	60	50	50

Permissible variation of mains voltage: $\pm 10\%$

Permissible variation of mains frequency: $\pm 5\%$

MOTOR

Type of duty according to IEC 60034-1/EN 15714-2

Type	3-phase AC	1-phase AC	DC current
SA 07.2 – SA 16.2	S2 - 15 min, S2 - 30 min/ classes A, B	S2 - 15 min ¹ / classes A, B ¹	S2 - 15 min/ classes A, B
SA 25.1 – SA 48.1	S2 - 15 min, S2 - 30 min/ classes A, B	–	–
SAR 07.2 – SAR 16.2	S4 - 25 %, S4 - 50 %/ class C	S4 - 25 % ¹ / class C ¹	–
SAR 25.1 – SAR 30.1	S4 - 25 %, S4 - 50 %/ class C	–	–
SQ 05.2 – SQ 14.2	S2 - 15 min/ classes A, B	S2 - 10 min/ classes A, B ¹	–
SQR 05.2 – SQR 14.2	S4 - 25 %, S4 - 50 %/ class C	S4 - 20 %/ class C1	–

Indications on type of duty refer to the following conditions: Nominal voltage, 40 °C ambient temperature, average load of approx. 35 % of maximum torque

Motor insulation classes

	Insulation classes
3-phase AC motors	F, H
1-phase AC motors	F
DC motors	F

Rated values for motor protection

Thermoswitches are used as standard motor protection. When using integral controls, motor protection signals are internally processed. This also applies for the optional PTC thermistors. For actuators without integral controls, signals must be processed via external controls.

Rating of the thermoswitches	
1-phase AC voltage (250 V AC)	Switch rating I_{max}
$\cos \varphi = 1$	2.5 A
$\cos \varphi = 0.6$	1.6 A
DC voltage	Switch rating I_{max}
60 V	1 A
42 V	1.2 A
24 V	1.5 A

Special motors

For special requirements, the actuators can be equipped with special motors, e.g. brake motors, two-speed motors or motors for longer run times.

¹ not available for all sizes



TERMINAL PLANS/ELECTRICAL CONNECTION

All diagrams show signal wirings to the 50 contact plug/socket connector and are the basis for connecting control cables and the power supply. They can be downloaded at www.auma.com.

- > TPA for SA/SAR multi-turn actuators and SQ/SQR part-turn actuators
- > MSP for AM actuator controls
- > TCP for AC actuator controls

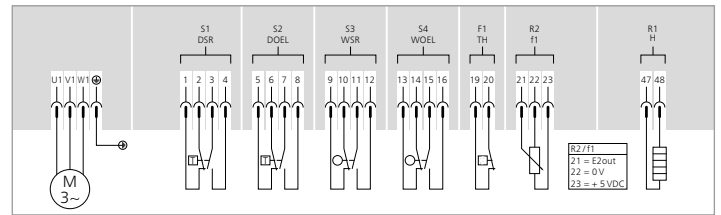

TPA terminal plan extract for an actuator

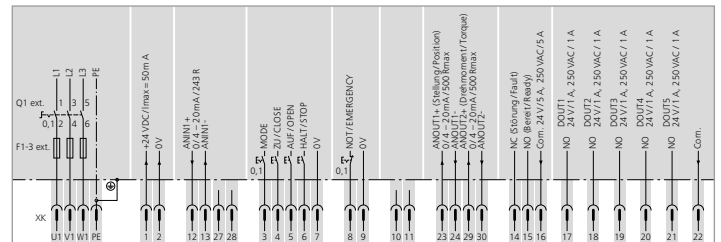

TPC terminal plan extract for AC controls

AUMA plug/socket connector			
	Power contacts	Protective earth	Control contacts
No. of contacts max.	6 (3 equipped)	1 (leading contact)	50 pins/sockets
Designations	U1, V1, W1, U2, V2, W2	PE	1 to 50
Connection voltage max.	750 V	–	250 V
Rated current max.	25 A	–	16 A
Type of customer connection	Screw connection	Screw connection for ring lug	Screw connection, crimp-type (option)
Connection diameter max.	6 mm ²	6 mm ²	2.5 mm ²
Material - pin socket carrier	Polyamide	Polyamide	Polyamide
Material - contacts	Brass	Brass	Brass, tin plated or gold plated (option)

Thread dimensions of cable entries (selected choice)		
	Electrical connection S	Electrical connection SH
M-threads (standard)	1 x M20 x 1.5; 1 x M25 x 1.5; 1 x M32 x 1.5	1 x M20 x 1.5; 2 x M25 x 1.5; 1 x M32 x 1.5
Pg-threads (option)	1 x Pg 13.5; 1 x Pg 21; 1 x Pg 29	1 x Pg 13.5; 2 x Pg 21; 1 x Pg 29
NPT-threads (option)	2 x 3/4" NPT; 1 x 1 1/4" NPT	1 x 3/4" NPT; 2 x 1" NPT; 1 x 1 1/4" NPT
G-threads (option)	2 x G 3/4"; 1 x G 1 1/4"	1 x G 3/4"; 2 x G 1"; 1 x G 1 1/4"

HEATER

Heater in control unit	Actuators without integral controls	Actuators with AM or AC
Heating element	Self-regulating PTC element	Resistance type heater
Voltage ranges	110 V – 250 V DC/AC 24 V – 48 V DC/AC 380 V – 400 V AC	24 V DC/AC (internal supply)
Power	5 W – 20 W	5 W

Motor heater	Actuators without integral controls
Voltages	110 – 120 V AC, 220 – 240 V AC or 380 – 400 V AC (externally supplied)
Power	12,5 W – 25 W ²

Heater for actuator controls	AM	AC
Voltages	110 – 120 V AC, 220 – 240 V AC, 380 – 400 V AC	
Temperature-controlled power	40 W	60 W

² depending on motor size, please refer to separate technical data sheets.

AM AND AC ACTUATOR CONTROLS

LOCAL OPERATION - LOCAL CONTROLS

	AM	AC
Operation	Selector switch LOCAL - OFF - REMOTE, lockable in all three positions Push buttons OPEN, STOP, CLOSE	Selector switch LOCAL - OFF - REMOTE, lockable in all three positions Push buttons OPEN, STOP, CLOSE, Reset
Indication	3 indication lights: End position CLOSED, collective fault signal, end position OPEN –	5 indication lights: End position CLOSED, torque fault in direction CLOSE, motor protection tripped, torque fault in direction OPEN, end position OPEN Graphic display with commutable white and red backlight Resolution 200 x 100 pixels

SWITCHGEAR

		AM and AC
		AUMA power classes
Reversing contactors, mechanically and electronically locked	Standard	A1
	Options	A2, A3, A4 ¹ , A5 ¹ , A6 ¹
Thyristors, electronically locked	Standard	B1
	Options	B2, B3

For more details on power classes and for thermal overload relay setting, please refer to the electrical data sheets.

AM AND AC – PARALLEL INTERFACE TO THE DCS

AM	AC
Input signals	
Standard Control inputs +24 V DC: OPEN, STOP, CLOSE via opto-isolator, one common	Standard Control inputs +24 V DC: OPEN, STOP, CLOSE, EMERGENCY, via opto-isolator (OPEN, STOP, CLOSE with one common)
Option As standard, with additional EMERGENCY input	Option As standard, with additional inputs for MODE and ENABLE
Option Control inputs at 115 V AC	Option Control inputs at 115 V AC, 48 V DC, 60 V DC, 110 V DC
Auxiliary voltage available for input signals	
24 V DC, max. 50 mA	24 V DC, max. 100 mA
115 V AC, max. 30 mA	115 V AC, max. 30 mA
Setpoint control	
	Analogue input 0/4 – 20 mA
Output signals	
Standard 5 output contacts, 4 NO contacts with common, max. 250 V AC, 0.5 A (resistive load) Default configuration: End position CLOSED, end position OPEN, selector switch REMOTE, selector switch LOCAL 1 potential-free change-over contact, max. 250 V AC, 5 A (resistive load) for collective fault signal: Torque fault, phase failure, motor protection tripped	Standard 6 output contacts can be assigned as desired using parameters, 5 NO contacts with one common, max. 250 V AC, 1 A (resistive load), 1 potential-free change-over contact, max. 250 V AC, 5 A (resistive load) Default configuration: End position CLOSED, end position OPEN, selector switch REMOTE, torque fault CLOSE, torque fault OPEN, collective fault signal (torque fault, phase failure, motor protection tripped)
	Option 12 output contacts can be assigned as desired using parameters, 10 NO contacts with one common, max. 250 V AC, 1 A (resistive load), 2 potential-free change-over contacts for collective fault signal max. 250 V AC, 5 A (resistive load)
	Option Independent change-over contacts without common, max. 250 V AC, 5 A (resistive load)
Continuous position feedback signal	
Position feedback signal, 0/4 – 20 mA	Position feedback signal, 0/4 – 20 mA

¹ Switchgear supplied in separate control cabinet

AM AND AC ACTUATOR CONTROLS

AC - FIELDBUS INTERFACE TO DCS

	Profibus	Modbus	Foundation Fieldbus	HART	Wireless
General information	Exchange of all discrete and continuous operation commands, feedback signals, status requests between actuators and DCS, as digital information				
Supported protocols	DP-V0, DP-V1, DP-V2	Modbus RTU	FF H1	HART	Wireless
Maximum number of participants	126 (125 field devices and one Profibus DP master) without repeater; i.e. max. 32 devices per Profibus DP segment	247 field devices and one Modbus RTU master Without repeater, i.e. max. 32 per Modbus segment	240 field devices including linking device. A maximum of 32 devices can be connected to a single Foundation Fieldbus segment.	64 field devices when implementing multidrop technology	250 per gateway
Max. cable lengths without repeater	Max. 1,200 m (for baud rates < 187.5 kbit/s), 1,000 m at 187.5 kbit/s, 500 m at 500 kbit/s, 200 m at 1.5 Mbit/s	Max. 1,200 m	Max. 1,900 m	Approx 3,000 m	Distance covered Outside approx. 200 m, Inside buildings approx. 50 m
Max. cable lengths with repeater	Approx. 10 km (only applies to baud rates < 500 kbit/s), Approx. 4 km (at 500 kbit/s) Approx 2 km (at 1.5 Mbit/s) The maximum possible cable length depends on type and number of repeaters. Typically, maximum 9 repeaters can be used in one Profibus DP system.	Approx. 10 km The maximum possible cable length depends on type and number of repeaters. Typically, maximum 9 repeaters can be used in one Modbus system.	Approx. 9.5 km The maximum cable length which can be implemented depends on the number of repeaters. For FF, cascading of max. 4 repeaters possible.	Use of repeaters possible, max. cable length corresponds to conventional 4 – 20 mA wiring.	Each device acts as repeater. Subsequently arranged devices are used to cover large distances.
Overtoltage protection (option)	Up to 4 kV			–	not required
Data transmission via fibre optic cables					
Supported topologies	Line, star, ring	Line, star	–	–	–
Cable length between 2 actuators	Multi-mode: up to 2.6 km at 62.5 µm glass fibre Single-mode: up to 15 km		–	–	–

DCS INTEGRATION TESTS – SELECTION

Fieldbus	Manufacturer	DCS	Fieldbus	Manufacturer	DCS
Profibus DP	Siemens	S7-414H; Open PMC, SPPA T3000	Modbus	Allen Bradley	SLC 500; Series 5/40; ControlLogix Controller
	ABB	Melody AC870P; Freelance 800F; Industrial IT System 800 XA		Emerson	Delta-V
	OMRON	CS1G-H (CS1W-PRN21)		Endress & Hausser	Control Care
	Mitsubishi	Melsec Q (Q25H with QJ71PB92V master interface)		General Electric	GE Fanuc 90-30
	PACTware Consortium e.V.	PACTware 4.1		Honeywell	TDC 3000; Experion PKS; ML 200 R
	Yokogawa	Centum VP (ALP 121 Profibus interface)		Invensys/Foxboro	I/A Series
Foundation Fieldbus	ABB	Industrial IT System 800 XA		Rockwell	Control Logix
	Emerson	Delta-V; Ovation		Schneider Electric	Quantum Series
	Foxboro/Invensys	I/A Series		Siemens	S7-341; MP 370; PLC 545-1106
	Honeywell	Experion PKS R100/R300		Yokogawa	CS 3000
	Rockwell	RSFieldBus			
	Yokogawa	CS 3000			

SUMMARY OF FUNCTIONS

	AM	AC
Operational functions		
Type of seating programmable	●	●
Automatic correction of the direction of rotation upon wrong phase sequence	●	●
Positioner	–	■
Feedback of intermediate positions	–	●
Approaching the intermediate positions directly from remote	–	■
Operation profiles with intermediate positions	–	■
Extended operating time due to timer	–	●
Programmable EMERGENCY behaviour	■	
Failure behaviour on loss of signal	■	●
Torque by-pass	–	●
Integral PID controller	–	■
Multiport valve function	–	■
Automatic deblocking	–	■
Monitoring functions		
Valve overload protection	●	●
Phase failure/phase sequence	●	●
Motor temperature (limit value)	●	●
Monitoring the admissible on-time (type of duty)	–	●
Manual operation activated	■	■
Operating time monitoring	–	●
Reaction to operation command	–	●
Motion detector	–	●
Communication to DCS via fieldbus interface	–	■
Wire break monitoring, analogue inputs	–	●
Electronics temperature	–	●
Diagnostics via continuous sensing of temperature, vibration	–	●
Heater monitoring	–	●
Monitoring of position transmitter in the actuator	–	●
Monitoring of torque sensing	–	●
Diagnostic functions		
Time-stamped event report	–	●
Electronic device ID	–	●
Operating data logging	–	●
Torque profiles	–	●
Status signals according to NAMUR recommendation NE 107	–	●
Maintenance recommendations regarding O-rings, lubricant, reversing contactors, and mechanics.	–	●

● Standard

■ Option

OTHER TYPE RANGES

In addition to the previously introduced SA and SQ type ranges, AUMA offers further product ranges to satisfy specific customer requirements:

- > Space constraints
- > Short operating times
- > Continuous modulating

FURTHER AUMA PRODUCTS

BASIC RANGE

Simple control and basic functions as well as feedback signals – these are the major characteristics required by our customers. BASIC RANGE actuators ensure reliable service over many years, following the install and forget philosophy. Operation commands and setpoints are implemented by means of binary or analogue voltage or current signals.

In the event of power failure, the valve can be operated by manual emergency operation included as standard.

SBA linear actuators

High positioning accuracy - the perfect choice for modulating applications.

- > Seven sizes
- > Thrust range: 0.6 kN – 25 kN
- > Stroke range: 35 mm – 100 mm

Applications: Temperature control of cooling water or lubricating oil; turbine control e.g. spear head adjustment in Pelton turbines

ED/EQ part-turn actuators

Simple and reliable part-turn actuators for open-close and modulating duty.

- > Eight sizes
- > Torque range: 25 Nm – 600 Nm
- > Swing angle range: 90 ° – 180°

Applications: Shut-off valves for by-pass, bleeding, lubricating oil or cooling water pipelines





SMART RANGE

Variable speed actuators for modulating applications requiring high positioning accuracy and/or for integration into DCS placing higher demands on the functionality of the field devices.

With regard to DCS integration, the product family is extremely flexible, including fieldbus interfaces for Profibus DP and Modbus RTU.

The actuators are equipped with a teach-in function which adapts positioning accuracy to changing marginal conditions.

Speed control is used for soft starts and stops acting gently on all mechanical components. Operation profiles with variable speed help to avoid critical states within the valve such as pressure surges or cavitation.

SDL/SDG linear actuators

Actuators for automating control valves fulfilling highest demands regarding positioning accuracy. A wide range power supply input caters for utmost power supply flexibility.

- > Three sizes
- > Thrust ranges: 4 kN – 15 kN
- > Stroke ranges: 55 mm – 300 mm
- > Modulating duty with continuous modulating (class D)
- > Available with 24 V DC power supply

Applications: Temperature control of cooling water or lubricating oil; turbine control e.g. spear head adjustment in Pelton turbines

SGC part-turn actuators and SVC globe valve actuators

Providing high torques at fast operating speed, SGC and SVC actuators are ideally suited for fast opening and closing. Internal speed control nevertheless protects the mechanics of actuator and valve. Variable speed leads to high positioning accuracy.

SGC part-turn actuators

- > Five sizes
- > Torque range: 25 Nm – 1,000 Nm
- > Swing angle ranges: 75° – 105°

Applications: Shut-off valves in water treatment plants, bulk handling systems, fire-fighting systems, turbine control

SVC globe valve actuators

- > Three sizes
- > Torque ranges: 10 Nm – 100 Nm
- > Stroke ranges: 60 mm and 70 mm
- > Turns per stroke: Subranges between 1 – 40 turns/stroke (>40 turns/stroke on request)

Applications: Shut-off valves, control valves for pressure or level control, turbine control

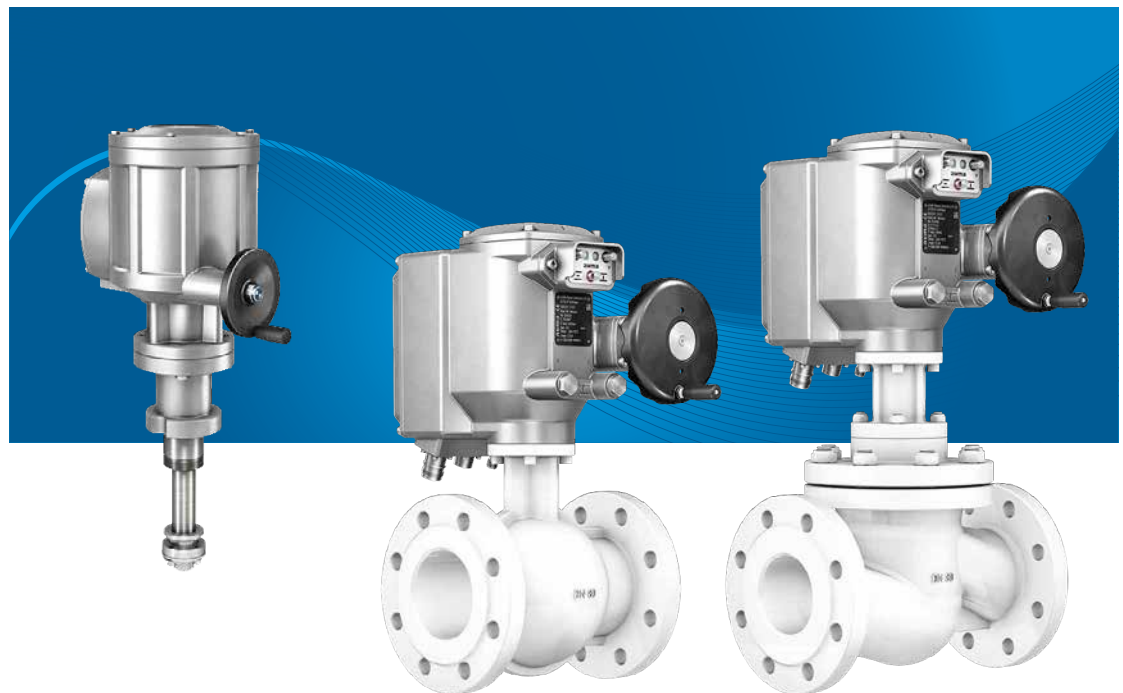

SERVICE

Decisive factors for civil engineering constructions for water applications and hydropower are long product life and operational safety. Sophisticated design and careful device production are an absolute must – and a worldwide service network ensuring availability of our AUMA actuators throughout their complete product life.

We at AUMA strive for long-term customer satisfaction and partnership by warranting the safe and smooth operation of our actuators. We attach great importance to customised advice and comprehensive service – throughout the entire product life cycle.

SERVICES

EXPERTISE IN YOUR NEIGHBOURHOOD

We do not go for call centres with endless waiting loops or online device configuration systems with direct order placement. As soon as the automation requirements become more complex - and actuators are part of systems with different levels of complexity - the direct support and advice provided by our service staff cannot be replaced by automatic ordering systems. This is how we ensure that our customers select the most suitable actuator solution.

AUMA's global service network with subsidiaries and representatives, established in 70 countries, is even subdivided in sections of competence at country level. The AUMA sales staff are informed about the latest developments by regular sales training.

Your special advantage: Competent support for AUMA products is available worldwide, helping you in selecting the suitable device - in your neighbourhood.

COMPREHENSIVE SERVICE

Whatever applies to customer support also applies to customer service. Our sales network is also a service network. We always care for you and our products.

Our service engineers know the AUMA devices by heart and their technical expertise in the field of device deployment is common knowledge. The best practice database is available for the AUMA service network, beneficial for both, the service staff and the customers.

Our AUMA service offers our customers all around the globe comprehensive service performance for actuators, actuator controls, and gearboxes. With our versatile service portfolio, we are your competent partner from installation and commissioning to training, maintenance, and overhaul or repair right through to global availability and supply of spare parts.

We guarantee availability for spare parts for at least 10 years after discontinuation of a product.





TAILORED MAINTENANCE

Preventive maintenance maximises plant availability. In compliance with the specified application conditions, we develop individual and tailored maintenance plans.

RETROFITTING AND CUSTOMISED PRODUCTION

There is no such thing as "impossible" with AUMA. Special and challenging installation conditions require special and customised solutions: Especially for buried service or when modernising existing plants where valve attachments are frequently not complying with standards. We offer extensive accessories and manufacture pedestals, lever arrangements, and other adapters to customer needs.

QUALITY IS NOT JUST A MATTER OF TRUST

Actuators must be reliable and dependable. They determine the cycle of precisely defined work processes. Reliability does not begin during commissioning.

For AUMA, this commences with a well-thought out design, careful selection of material used and conscientious production using state-of-the-art machinery. With clearly controlled and supervised production steps we pay close attention to the environment.

The importance of environmentally sound production is reflected in our certifications according to ISO 9001 and ISO 14001.

However, quality management is no one-time or static matter. It has to be proven day by day. Numerous audits by our customers and independent institutes confirm these high standards.

ZERTIFIKAT ■ CERTIFICATE ■ CERTIFICADO ■ CERTIFICAT ■ CERTIFIKAT ■ 認證證書 ■ CERTIFICATE ■ ZERTIFIKAT ■ CERTIFICATE ■



CERTIFICATE

The Certification Body
of TÜV SÜD Management Service GmbH

certifies that



AUMA Riester GmbH & Co. KG
Aumastr. 1, 79379 Müllheim
Germany

has established and applies a
Quality, Environmental,
Occupational Health and Safety Management System
for the following scope of application:

**Design and development, manufacture, sales and service of
electric actuators, integral controls and gearboxes for
valve automation as well as components for
general actuation technology.**

Performance of audits (Report-No. 70009378)
has furnished proof that the requirements under:

ISO 9001:2008

ISO 14001:2004

OHSAS 18001:2007

are fulfilled. The certificate is valid in conjunction
with the main certificate from **2015-06-09** until **2018-06-08**.
Certificate Registration No. **12 100/104/116 4269/01 TMS**



Product Compliance Management
Munich, 2015-06-09



Deutsche
Akkreditierungsstelle
D-ZM-14143-01-03
D-ZM-14143-01-04
D-ZM-14143-01-05

TÜV SÜD Management Service GmbH • Zertifizierungsstelle • Ridlerstraße 65 • 80339 München • Germany
www.tuev-sued.de/certificate-validity-check



EU DIRECTIVES

Declaration of Incorporation in compliance with the Machinery Directive and Declaration of Conformity according to the Low Voltage and EMC Directives.

According to the Machinery Directive, AUMA actuators and valve gearboxes are considered as partly completed machinery. By means of the Declaration of Incorporation, AUMA certify that during the design stage of the devices, the fundamental safety requirements stipulated in the Machinery Directive were applied.

AUMA actuators fulfil the requirements of the Low Voltage and EMC Directives. This has been proved in various exams and extensive tests. Consequently, AUMA issue a Declaration of Conformity in compliance with the Low Voltage and EMC Directives.

Declarations of Incorporation and of Conformity are combined in a single certificate.

According to the Low Voltage and EMC directives, the devices are labelled with the CE mark.



INSPECTION CERTIFICATE

After assembly, every single actuator is thoroughly tested and torque switches are calibrated. This process is recorded in the inspection certificate.

CERTIFICATES

Notified bodies perform type tests on the actuators to prove whether the devices are suitable for specifically defined applications. One example are the tests to prove electrical safety for the North American market. For all devices mentioned in this brochure, relevant certificates are available.

Where can I get the certificates?

All confirmations, records and certificates are filed at AUMA and provided as printed or digital version on request.

The documents can be downloaded from the AUMA website at any time; some of them are password protected.

> www.auma.com



AUMA Riester GmbH & Co. KG

Aumastr. 1
79379 Muellheim
Germany
Tel +49 7631 809-0
Fax +49 7631 809-1250
info@auma.com

AUMA subsidiaries and representatives
are implanted in more than 70 countries.
For detailed contact information,
please refer to our website.

www.auma.com

FOR THE PURPOSES OF THIS ACT, THE FOLLOWING DEFINITIONS APPLY:

(1) "Business" means any trade, profession, occupation, or service, whether or not it is a business as defined in the Income Tax Act.

(2) "Company" means a corporation, whether or not it is a company as defined in the Income Tax Act.

(3) "Individual" means a natural person, whether or not it is an individual as defined in the Income Tax Act.

(4) "Partnership" means a partnership, whether or not it is a partnership as defined in the Income Tax Act.

(5) "Trust" means a trust, whether or not it is a trust as defined in the Income Tax Act.

(6) "Sole proprietorship" means a sole proprietorship, whether or not it is a sole proprietorship as defined in the Income Tax Act.

(7) "Partnership agreement" means an agreement, whether or not it is a partnership agreement as defined in the Income Tax Act.

(8) "Trust agreement" means an agreement, whether or not it is a trust agreement as defined in the Income Tax Act.

(9) "Sole proprietorship agreement" means an agreement, whether or not it is a sole proprietorship agreement as defined in the Income Tax Act.

(10) "Business agreement" means an agreement, whether or not it is a business agreement as defined in the Income Tax Act.

(11) "Company agreement" means an agreement, whether or not it is a company agreement as defined in the Income Tax Act.

(12) "Individual agreement" means an agreement, whether or not it is an individual agreement as defined in the Income Tax Act.

(13) "Partnership agreement" means an agreement, whether or not it is a partnership agreement as defined in the Income Tax Act.

(14) "Trust agreement" means an agreement, whether or not it is a trust agreement as defined in the Income Tax Act.