

# 2-Way Sensing Valve

---

## Model 4109B - Vibro-Guard

### Typical applications

- Motors
- Engines
- Pumps
- Compressors
- Fan drives
- Any moving equipment



**Model 4109B**

### Key features and benefits

- Gulf-proofed finish
- Pneumatic and electric versions available
- Reliable repeatability
- Pneumatic reset/override available

# 2-Way Sensing Valve - Model 4109B - Vibro-Guard

---

## Contents

---

Overview .....	3
Operation .....	3
Installation .....	3
Adjustment .....	4
Resetting .....	4
Response Graph .....	4
Typical Piping Diagram .....	5
How to Order .....	5
Dimensions .....	6
Specification .....	7
Maintenance and Service Parts .....	7
How to order service kits .....	7
Service kit model number structure .....	8
Service parts .....	8
Contact .....	10

# 2-Way Sensing Valve - Model 4109B - Vibro-Guard

## Overview

AMOT Model 4109 Vibro-Guard Valve is a 2-way acceleration sensing valve with optional electric microswitch. This unit is weatherproof and corrosion protected for salt spray atmospheres (Gulfproofed).

Failing bearings, broken blades, cracked, broken or bent shafts, misfiring, and accumulated deposits are a few of the items which the Vibro-Guard can detect.

## Operation

Model 4109 makes use of a pivoted lever assembly with a high strength, potted magnet near the end opposite the pivot. When the unit is reset, the magnet is thrust toward the steel armature embedded in the base and is held there by magnetic force plus the force of the loading spring until the inertia of the lever assembly exceeds the holding force of the magnet and spring. When this occurs, the lever assembly snaps to the tripped position and remains there until manually or pneumatically reset.

Tripping of the lever assembly allows the valve to vent. Changes in adjustment are made by removing the cover and turning adjusting wheel which changes the spring bias.

## Installation

Vibro-Guard Valves are sensitive in the direction parallel to the axis of the reset plunger. This axis must be parallel to the direction of the anticipated motion of the protected machine. When used to detect vibration in the horizontal plane, the Vibro-Guard should be attached to a vertical surface with the reset port at the bottom. Mounted in this way, the AMOT name on the cover will read in an upright position. Some general installation locations are given in figures 1, 2 and 3.

If brackets are to be used in mounting the units on irregular surfaces, they should be of  $\frac{1}{4}$ " minimum thickness steel, rigidly secured to prevent generation of undesired vibrations.

When making electrical connections to Vibro-Guard's electrical switch, the nameplate <sup>34</sup> can be removed to facilitate making electrical connections. The lead wires may be left inside the housing as long as they don't interfere with the action of the lever assembly. Lead wires provided are 6 inches long, AWG #18 stranded, and are color-coded red, white, and black as shown in figure 4. A junction box may be attached at the  $\frac{1}{2}$ " NPT conduit connection if desired to facilitate the joining and storage of heavier wiring.

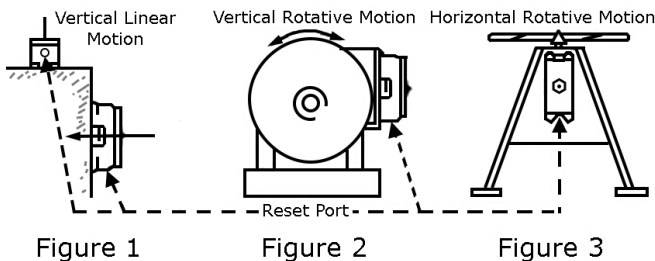

The 4109 is provided with 2 vent ports, Vent A and Vent B, both of which vent the valve and the case. Use Vent A with air control systems venting to atmosphere where rain or moisture may enter Vent B which faces up. Install the 4125 vent closure on Vent A, plug Vent B. Use Vent B with gas control systems and piped vents. Plug Vent A with the plug provided.

Connecting tubing should be  $\frac{1}{4}$ " O.D. minimum. Apply a good quality sealant such as Loctite™ Pipe Sealant to pipe threaded connections. Ensure that all connecting tubing and fittings are clean and that no chips, dirt, rust, sealant, etc. are allowed to enter the valve.

### SNAP SWITCH CONNECTIONS

Models 4109B11B and 4109B12B

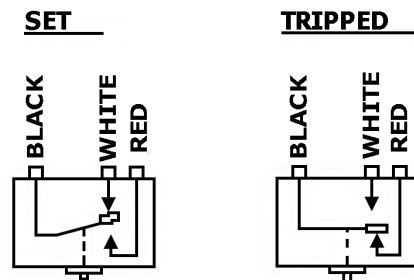

Figure 4

# 2-Way Sensing Valve - Model 4109B - Vibro-Guard

## Adjustment

- Vibro-Guard is factory set at approximately 2 G's in the horizontal position. Should this setting not be suitable for the intended application, an adjustment will be necessary.
- To adjust the trip point, isolate the Vibro-Guard from the safety circuit and bring the protected machine to its rated speed and load.
  - 1) Remove cover ④⑦ and check lever assembly ②④ to see if the unit has tripped. If it has, attempt to reset by firmly pressing the rectangular leaf spring on the lever assembly at Point B (see assembly drawing on page 9).
  - 2) If the unit stays latched, increase the sensitivity by rotating the top of the adjusting wheel ⑧ away from the nameplate ③④. If the unit will not reset, decrease the sensitivity by rotating the top of the wheel toward the nameplate.
  - 3) After the trip point has been determined, decrease the sensitivity (rotate top of adjusting wheel ⑧ toward the nameplate ③④) to a point where the equipment will continue to operate under normal conditions without causing tripping of the Vibro-Guard.
    - This may be from 30° to 90° depending on the type and purpose of the machine.
    - A change of 1G in the setting requires approximately 1 ½ turns of the adjusting wheel.
  - 4) Replace cover ④⑦ after making the final setting.

## Resetting

The Vibro-Guard is reset manually by pressing firmly on the reset button ③⑧ in the middle of the cover. It can be remotely set or "locked out" by pressurizing the reset port with 2 - 17 bar (30 - 250 psi). Clean dry air or gas should be used in the control and reset systems.

Be sure that the reset pressure is vented to atmosphere or to a manifold where there will be zero residual pressure, or the vent may not be completely "unlocked" when the reset pressure is removed.

## Response Graph

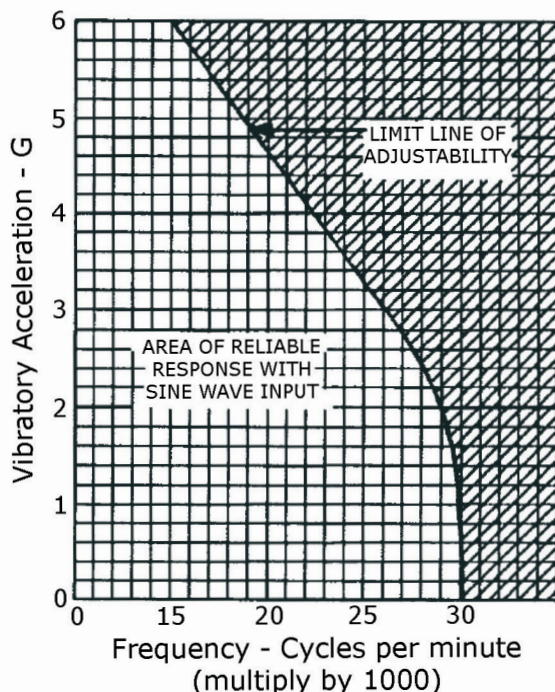

# 2-Way Sensing Valve - Model 4109B - Vibro-Guard

## Typical Piping Diagram

This circuit will actuate a Master Safety Control or Pressure Operated Valve upon excessive vibration as detected by the AMOT Model 4109.

The Pneumatic Indicating Relay will show the cause of the shutdown and the Model 4057 Valve can be used to remotely rest or override the 4109.

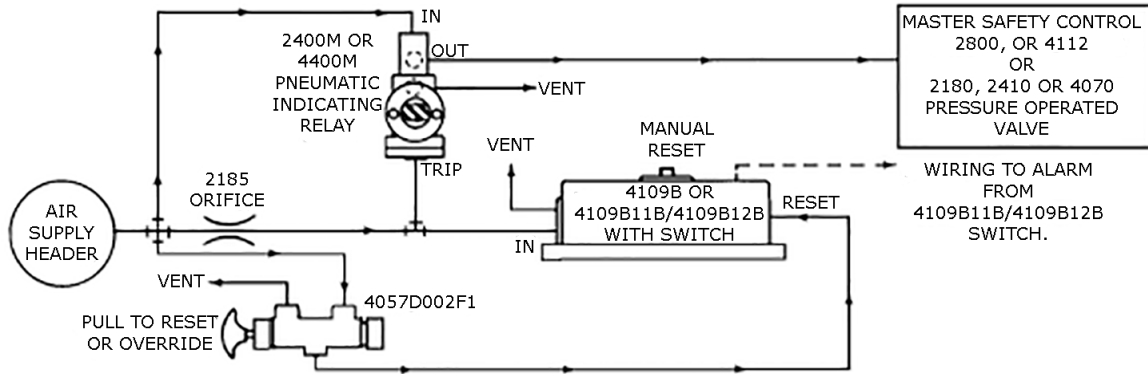

## How to Order

Use the following table to select the unique specification of your Model 4109 Vibro-Guard valve.

Example	4109B	1	0	B	Code description	Comments
					<b>Basic model (A)</b>	
<b>Basic model (A)</b>	4109B					
					<b>Thread and finish (B)</b>	
<b>Thread and finish (B)</b>		1			NPT, Gulfproofed	
					<b>Switch (C)</b>	
<b>Switch (C)</b>			0		Without switch	
			1		With SPDT switch	Silver contacts
			2		With SPDT switch	Gold contacts
					<b>Seal material (D)</b>	
<b>Seal material (D)</b>				B	Viton	
					<b>Customer special requirements (E)</b>	
<b>Customer special requirements (E)</b>				-AA	Standard	May be omitted
				-***	Made-to-order	

# 2-Way Sensing Valve - Model 4109B - Vibro-Guard

## Dimensions

Dimensions - inches (mm)

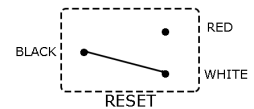
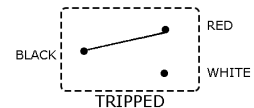
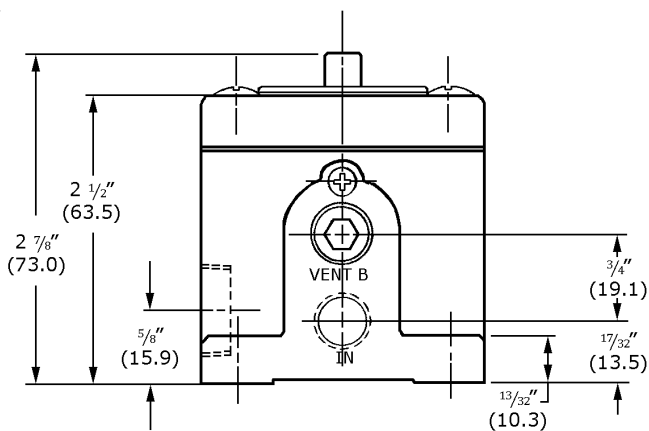
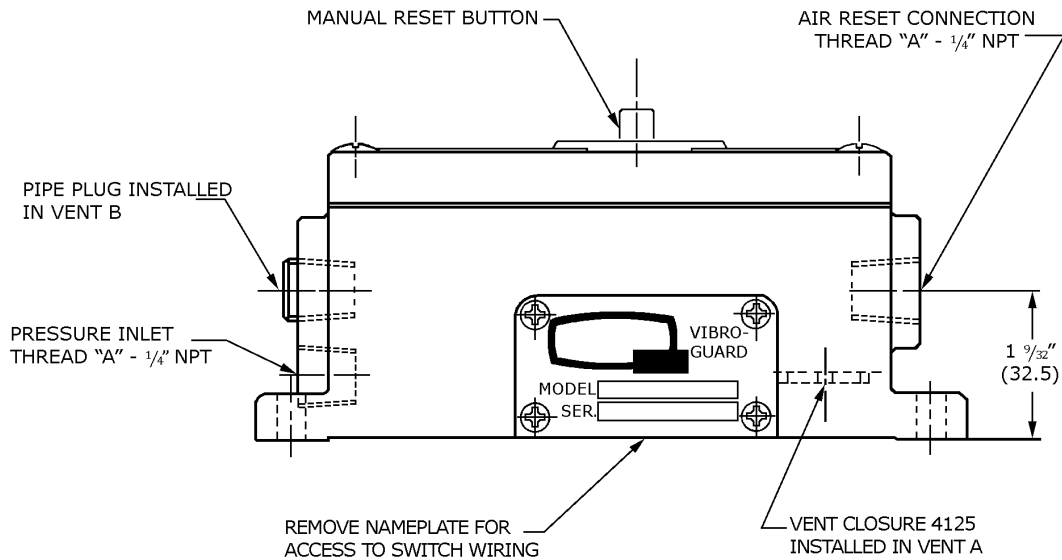
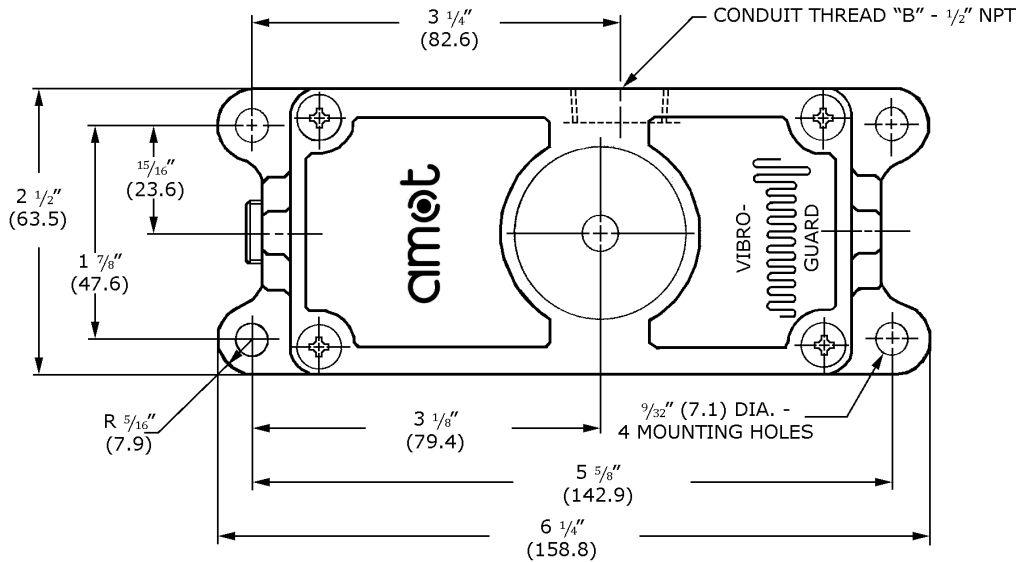

STANDARD SWITCH CONNECTION

# 2-Way Sensing Valve - Model 4109B - Vibro-Guard

## Specification

		Metric units	English units
<b>Housing and cover material</b>	Precision cast aluminum black anodized		
<b>Internal parts</b>	Aluminum or plated steel		
<b>Standard seals</b>	Viton		
<b>Maximum operation temperature</b>		93°C	200°F
<b>Maximum valve inlet pressure</b>		6.2 bar	90 psi
<b>Reset pressure</b>		2.1 - 17.2 bar	30 - 250 psi
<b>Valve capacity (tripped) at 20 psi</b>		0.09 m <sup>3</sup> /min	3 scfm
<b>Flow coefficient</b>		Kv = 0.17	Cv = 0.2
<b>Vibration sensing range</b>	On horizontal surface	6G	
	On vertical surface	5G	
<b>Switch ratings</b>	125/250 VAC	¼ hp	
	125/250 VAC	10 amp	
	28 VDC (inductive)	3 amp	
	28 VDC (max. inrush)	24 amp	
<b>Net weight</b>		1.25 kg	2.75 lb

## Maintenance and Service Parts

Over time, exposure to foreign chemicals and particulate matter as well as prolonged operation at extreme conditions may reduce the effectiveness of the valve. At such time, AMOT Vibro-Guard 2-Way Sensing Valves can be restored to original performance simply by installing an AMOT vibro-guard 2-way sensing valve service kit. Service kits include all new seals and seal components required for normal maintenance.

***AMOT recommends an inspection of the unit at yearly intervals is adequate to detect and make provisions for normal wear. AMOT also recommends that inspection and cleaning be incorporated in a normal preventative maintenance program.***

### How to order service kits

Service kits are available with the parts required to properly service the valve. Order service kits using the service kit model number, which is identified by the switch code found in the AMOT valve part number.

AMOT designs and tests all its products to ensure that high quality standards are met. For good product life, carefully follow AMOT's installation and maintenance instructions; failure to do so could result in damage to the equipment being protected or controlled.

Refer to the AMOT valve part number printed in the valve nameplate and the AMOT valve part number structure on page 5.

# 2-Way Sensing Valve - Model 4109B - Vibro-Guard

## Maintenance and Service Parts Continued

### Service kit model number structure

1) Identify the switch code, located in the Switch (C) section of the AMOT valve part number.

2) Identify that code in the service kit identification table below to identify the service kit for your valve.

Service kit identification					
		Switch (C)			Service kit model no.
		0			9163X002
		1			9163X004
		2			9163X006
Examples					
Valve part no.					Service kit model no.
4109B	1	0	B		9163X002
4109B	1	1	B	-AA	9163X004
4109B	1	2	B		9163X006

### Service parts *(refer to diagrams on page 9)*

Service kit parts				
Ref no.	Qty.			Description
	9163X002	9163X004	9163X006	
6	1	1	1	Valve assembly
9	-	1	1	Switch assembly
10	1	1	1	Seal washer
13	-	1	1	Insulator
37	1	1	1	Reset button seal
42	1	1	1	Piston seal
43	1	1	1	Reset cylinder seal
46	1	1	1	Gasket
55	2	2	2	Seal



# 2-Way Sensing Valve - Model 4109B - Vibro-Guard

## Maintenance and Service Parts Continued

### Service parts continued

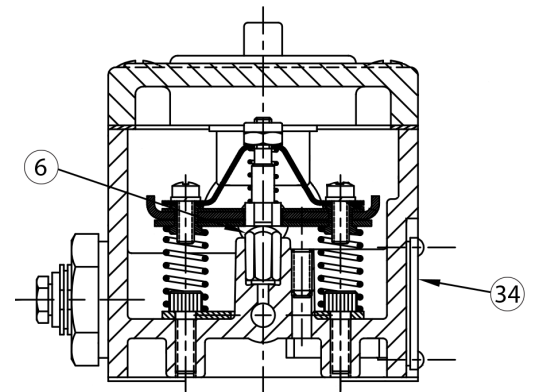
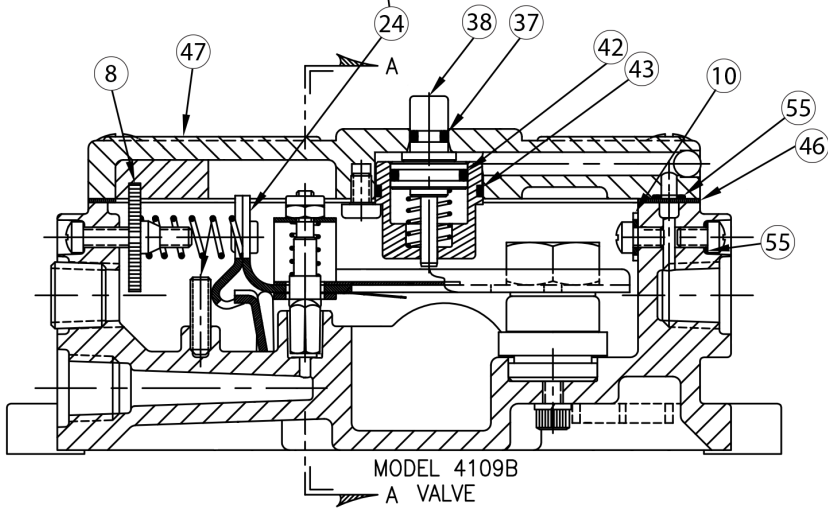
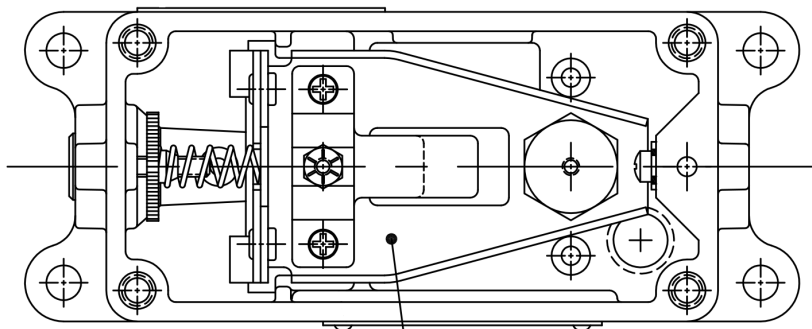
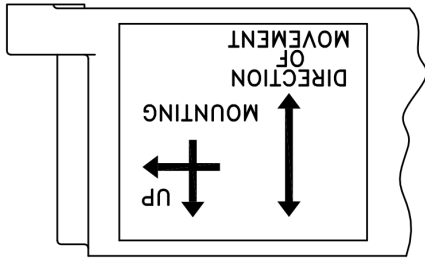

SECTION A-A

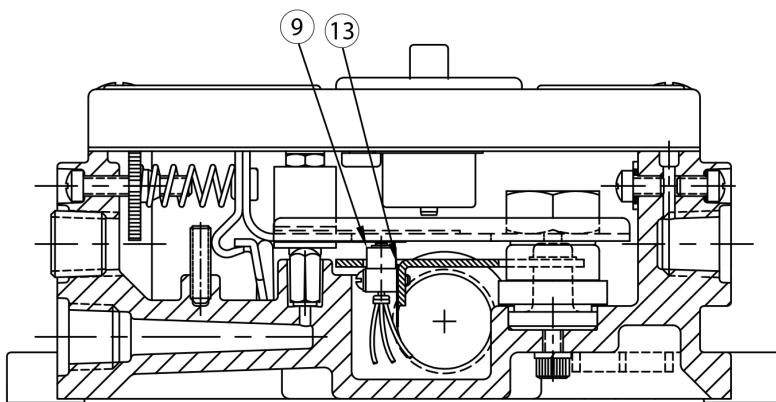

# 2-Way Sensing Valve - Model 4109B - Vibro-Guard

## Contact

---

### Americas

---

AMOT USA  
8824 Fallbrook Dr.  
Houston, TX 77064  
USA

Tel: +1 (281) 940 1800  
Fax: +1 (713) 559 9419  
Email: [customer.service@amot.com](mailto:customer.service@amot.com)

### Asia Pacific

---

AMOT Shanghai  
Bd. 7A, No. 568, Longpan Rd., Malu Jiading  
Shanghai 201801  
China

Tel: +86 21 5910 4052  
Fax: +86 21 5237 8560  
Email: [shanghai@amot.com](mailto:shanghai@amot.com)

### Europe, Middle East and Africa

---

AMOT UK  
Western Way  
Bury St. Edmunds  
Suffolk, IP33 3SZ  
England

Tel: +44 1284 715739  
Fax: +44 1284 760256  
Email: [info@amot.com](mailto:info@amot.com)

AMOT Germany  
Rondenbarg 25  
22525 Hamburg  
Germany

Tel: +49 40 8537 1298  
Fax: +49 40 8537 1331  
Email: [germany@amot.com](mailto:germany@amot.com)



#### **WARNING**

This product can expose you to chemicals including Lead, which is known to the state of California to cause cancer and birth defects or other reproductive harm. For more information go to [www.P65Warnings.ca.gov](http://www.P65Warnings.ca.gov).